

**ACADEMIC
TASK FORCE**

MATHEMATICS SPECIALIST

Year 12 ATAR COURSE

Units 3 and 4

A fully worked out Solution Manual for this book is
available as a resource to Teachers at
www.academictaskforce.com.au

O. T. Lee

© Academic Group Pty Ltd (ABN 50 151 087 286) trading as Academic Task Force

ISBN: 978-1-74098-182-8

This book is copyright. Apart from any fair dealing for the purposes of private study, research, criticism or review as permitted under the Copyright Act, no part may be reproduced by any means without written permission.

Academic Task Force
P.O. Box 627
Applecross
Western Australia 6953
Tel. 9314 9500
Fax. 9314 9555
Email: learn@academictaskforce.com.au

Printed in Singapore.

Contents

1. Complex Numbers I	1
1.1 Complex Numbers as Ordered Pairs	1
1.1.1 Complex Numbers in Polar Form	2
1.2 Operations on Complex Numbers in Polar Form	4
1.2.1 Product and quotient of two complex numbers	4
1.2.2 de Moivre's Theorem	4
1.3 Argand Diagrams	7
1.3.1 Geometrical Properties of Complex Numbers	7
1.4 Locus	11
1.4.1 Locus involving $\text{Re}(z)$ and $\text{Im}(z)$	11
1.4.2 Locus involving the Modulus	12
1.4.3 $\text{Arg}(z) = \theta$ (θ is constant)	15
1.4.4 Locus in general	16
2. Complex Numbers II	19
2.1 The Fundamental Theorem of Algebra	19
2.1.1 Roots of Complex Numbers	19
2.1.2 Formalising the method to determine the n -th roots of a number	21
2.2 Complex Numbers and Trigonometry	23
2.3 Complex Numbers in Exponential Form	26
3. The Factor and Remainder Theorems	32
3.1 The Factor Theorem	32
3.2 The Remainder Theorem	35
3.2.1 Quotients and Remainders	35
3.2.2 The Remainder Theorem	36
3.3 Extension to the Factor and Remainder Theorems	40
3.3.1 The Complex Conjugate Root Theorem	41
4. Functions	45
4.1 Review of functions	45
4.1.1 Onto Functions	45
4.1.2 One to One and Many to One Functions	46
4.2 Composition of Functions	49
4.3 Inverse of a Function	57
5. Sketching Techniques	63
5.1 Graphs of Inverse Functions	63
5.2 Graphs of Reciprocals $y = \frac{1}{f(x)}$	64
5.3 Graphs of Absolute Value Functions $y = f(x) $	68
5.4 Graphs of $y = f(x)$	70
5.5 Rational Functions	74
5.5.1 Rational Functions with oblique asymptotes	82
6. Vectors I	84
6.1 Vectors in Three Dimensional Space	84
6.1.1 Magnitude and Orientation	85
6.2 Algebraic & Geometrical Properties of 3D vectors	85
6.3 Vector Cross Product	93

7. Vectors II	98
7.1 Vector Equation of a Line	98
7.1.1 Parametric Equation of a Line in 3D	101
7.1.2 Cartesian Equation of a Line in 3D	101
7.2 Scalar Product Equation of a Line in 2D	105
7.3 Vector Equation of a Plane	107
7.3.1 Alternative form for the vector equation of a plane	110
7.3.2 Angle between line and plane	112
7.3.3 Angle between two planes	113
7.4 Vector Equation of a Sphere	115
7.5 Shortest Distance	118
7.5.1 Shortest Distance between point and line	118
7.5.2 Shortest Distance between point and plane: Scalar Projection Method	119
8. Vectors III	122
8.1 Vector Functions	122
8.2 Applications involving vector functions	124
9. Geometric Proofs using Vectors	129
9.1 Plane Geometry	129
9.2 Geometry in 3D Space	133
10. Systems of Linear Equations	136
10.1 3×3 Systems	136
10.2 3×3 Systems with Unique Solutions	137
10.2.1 The Gaussian Elimination Method for 3×3 Systems	137
10.3 Existence of Solutions for 3×3 Systems	145
11. Differentiation	152
11.1 Review of Rules of Differentiation	152
11.2 Differentiating Parametric Functions	156
11.3 Implicit Differentiation	158
11.4 Logarithmic Differentiation	162
12. Applications of Differentiation	164
12.1 The Gradient Function for Implicit Functions	164
12.2 Related Rates	166
13. Anti-Differentiation	172
13.1 Anti-differentiation as the reverse of Differentiation	172
13.2 Anti-differentiation I	173
13.3 Anti-derivative of $\frac{f'(x)}{f(x)}$	176
13.4 Standard Trigonometric Integrals	178
13.5 Integration of Trigonometric Functions in General	181
13.5.1 Even powers of $\sin(ax + b)$ and $\cos(ax + b)$	181
13.5.2 Odd powers of $\sin(ax + b)$ and $\cos(ax + b)$	183
13.5.3 Integrals of $\sin^m(ax + b) \cos^n(ax + b)$	184
13.6 Integration using the Method of Substitution/Change of Variable	185
13.6.1 Integration using Trigonometric Substitutions	189
13.7 Integration using Partial Fractions	191
13.7.1 Proper Fractions	191
13.7.2 Partial Fractions	191
Addendum: Heaviside Cover-up Method	195

14. Definite Integration	196
14.1 Integrals expressed as partial fractions	196
14.2 Method of Substitution	197
14.3 Area of Regions Trapped between Curves	199
14.4 Volume of Revolution	203
14.4.1 About the x -axis	203
14.4.2 About the y -axis	204
14.4.3 Volume generated by region trapped between two curves	205
15. Numerical Integration	208
15.1 Numerical Methods	208
15.2 The Rectangular Rules	208
15.3 The Trapezium Rule	210
15.4 Simpson's Rule	212
16. First Order Differential Equations	214
16.1 First Order Differential Equations of form $\frac{dy}{dx} = f(x)$	214
16.2 First Order Differential Equations of the form $\frac{dy}{dt} = g(y)$	216
16.2.1 First Order Differential Equation of the form $\frac{dy}{dt} = ay + b$	216
16.2.2 Separation of Variables Method for solving $\frac{dy}{dt} = ay + b$	216
16.2.3 Separation of Variables Method for solving logistic equations: $\frac{dy}{dt} = ay(b - y)$	222
16.3 First Order Differential Equations of the form $\frac{dy}{dx} = f(x)g(y)$	228
16.4 Slope/Direction Fields of First Order Differential Equations	229
16.4.1 Drawing slope fields	230
16.4.2 Isoclines	235
17. Rectilinear Motion	238
17.1 Displacement, Velocity and Acceleration	238
17.2 The Second Order Differential Equation $\frac{d^2x}{dt^2} = -\omega^2 x$	245
17.2.1 Properties of variables satisfying $\frac{dy}{dx} = -\omega^2 x$	246
17.2.2 Simple Harmonic Motion	246
18. Vector Calculus	253
18.1 Derivatives and Integrals of Vector Functions	253
18.2 Displacement, Velocity and Acceleration Vectors	256
18.3 Motion in a plane (2-dimensions)	260
18.3.1 Circular and Elliptical Motion	261
18.3.2 Projectile Motion	266

19. The Central Limit Theorem	272
19.1 Sampling Distributions	272
19.2 The Central Limit Theorem	276
19.3 Simulations of a Sampling Distribution of Sample Means	283
20. Point & Interval Estimates for μ	288
20.1 Point Estimate for population mean μ	288
20.2 Point Estimate for population standard deviation σ	288
20.3 Sampling distributions of sample means when σ is not known	289
20.4 Probability distribution for $\frac{\bar{X} - \mu}{\left(\frac{s}{\sqrt{n}}\right)}$	290
20.5 Interval Estimates	294
20.5.1 Confidence Intervals for μ	294
20.5.2 Calculating Confidence Intervals	295
20.6 Level of significance	304
20.7 Simulating Confidence Intervals for the Population Mean μ	307
Answers	308
Index	347

Preface

This book addresses the syllabus requirements of Units 3 and 4 of the Mathematics Specialist course of Western Australia.

The use of CAS/graphic calculators is seamlessly integrated into the teaching and learning process. Questions have become more explicit in terms of the required methods and techniques. Knowledge of CAS/graphic calculator techniques empower students to appreciate the relative efficiencies (and accuracies) of *machine based* techniques against traditional pencil and paper techniques. However, the traditional pencil and paper techniques are the ones that convey the actual mathematical concepts and processes and form the backbone of this book. Machine based techniques are at best interpretative techniques.

The use of Hands-on-Tasks is continued in this book. These tasks allow students to conceptualise mathematical concepts on their own without being explicitly “taught”. This promotes relational understanding rather than factual knowledge of mathematical concepts and ideas.

A fully worked out ***Solution Manual*** is available as a resource for teachers at www.academictaskforce.com.au.

Dr O.T. Lee
Mathematics Department
North Lake Senior Campus

Acknowledgments

My sincere thanks and appreciation go to:

- My wife Su and my now adult children David, Mark, Cheryl and Deborah for their unfailing support and help.
- The Casio Education Division for the use of the ClassPad Manager Professional.
- The teachers and students who have offered advice/suggestions in the writing of this textbook.

Errors in the text and solutions are entirely mine.

01 Complex Numbers I

1.1 Complex Numbers as Ordered Pairs

- A complex number consists of two parts, the real part and the imaginary part. The Cartesian representation,

$$z = (\text{real part}) + (\text{imaginary part})i$$

provides some distinct algebraic advantages as observed in the preceding course.

- However, rather than using the "+" sign to bring the two parts together, we could rewrite z as;

$$(\text{real part}, \text{imaginary part}).$$

In so doing we have represented complex numbers as ordered pairs.

- An Argand diagram consists of a set of x - y axes. The x -axis is labelled the Real axis and the y -axis is labelled the Imaginary axis. A complex number $x + yi$ can be represented on an Argand diagram either as an ordered pair (x, y) or as a vector.

- For example the complex number $z = 4 + 4i$ is represented as the point $A(4, 4)$ or as a vector \mathbf{OA} on an Argand diagram.

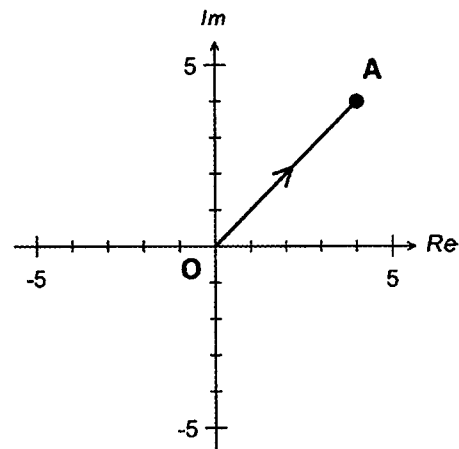

- However, points expressed in Cartesian coordinates can be converted into points in polar coordinates. Hence, the complex number $z = 4 + 4i$ can also be represented as the point $A [4\sqrt{2}, \frac{\pi}{4}]$.

- Round brackets will be used for Cartesian coordinates while square brackets will be used for polar coordinates.

1.1.1 Complex Numbers in Polar Form

- A complex number $x + yi$ can be represented as a *Cartesian/ rectangular ordered pair* (x, y) or as a *polar ordered pair* $[r, \theta]$.
- Graphically, a complex number can be represented as a point (x, y) or $[r, \theta]$ or as a directed line segment joining the origin to the point (x, y) or $[r, \theta]$.

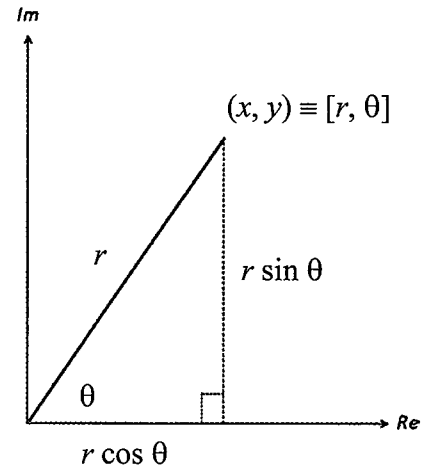

- Consider the complex number $z = x + yi$.
Hence $x + yi \equiv (x, y) \equiv [r, \theta]$
The modulus of z , $r = \sqrt{x^2 + y^2}$
The argument of z , θ , is given by $\tan \theta = \frac{y}{x}$ where $-\pi < \theta \leq \pi$
The modulus of z is the polar distance r and the argument of z is the polar angle θ .

- Expressing x and y in terms of r and θ :

$$x = r \cos \theta \quad \text{and} \quad y = r \sin \theta.$$

Hence

$$\begin{aligned} z &= x + yi \\ &= r \cos \theta + (r \sin \theta) i \\ &= r (\cos \theta + i \sin \theta) \\ &= r \text{ cis } \theta \end{aligned}$$

where *cis* θ is the "abbreviation" for the expression $(\cos \theta + i \sin \theta)$.

- Hence, in summary:

$z = x + iy$	algebraic Cartesian/rectangular form
$= r \text{ cis } \theta$	algebraic polar form
$= (x, y)$	ordered pair – Cartesian/rectangular form
$= [r, \theta]$	ordered pair - polar form.
where $r = \sqrt{x^2 + y^2}$	
$\tan \theta = \frac{y}{x}$	$-\pi < \theta \leq \pi$

- In particular:

$$\begin{aligned} 1 &\equiv (1, 0) \equiv \text{cis } 0 \equiv [1, 0] & i &\equiv (0, 1) \equiv \text{cis } (\pi/2) \equiv [1, \pi/2] \\ -1 &\equiv (-1, 0) \equiv \text{cis } \pi \equiv [1, \pi] & -i &\equiv (0, -1) \equiv \text{cis } (-\pi/2) = [1, -\pi/2] \end{aligned}$$

- In Cartesian/rectangular form, the conjugate of $z = x + yi$ is $\bar{z} = x - yi$.
In polar form, the conjugate of $z = r \text{ cis } \theta$ is $\bar{z} = r \text{ cis } (-\theta)$.

Example 1.1

Find in exact form, the modulus and argument of $-\sqrt{3} + i$.

Hence, rewrite $-\sqrt{3} + i$ in exact polar (*cis*) form.

Solution:

$$\text{Modulus} = \sqrt{3+1} = 2$$

$$\tan \theta = -1/\sqrt{3} \quad \text{in Quadrant 2}$$

$$\theta = \frac{5\pi}{6}$$

$$\text{Hence, } -\sqrt{3} + i = 2 \operatorname{cis} \frac{5\pi}{6}.$$

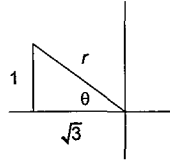

```
toPol([-sqrt(3), 1])
[2 [5*pi/6]]
```

```
compToTrig(-sqrt(3)+i)
2 * (cos(5*pi/6) + sin(5*pi/6) * i)
```

Example 1.2

Convert $2 \operatorname{cis} \frac{\pi}{4}$ into exact algebraic Cartesian/rectangular form:

Solution:

$$\begin{aligned} 2 \operatorname{cis} \frac{\pi}{4} &= 2 \cos \frac{\pi}{4} + i \sin \frac{\pi}{4} \\ &= \sqrt{2} + i \sqrt{2} \end{aligned}$$

```
toRect([2, 2*(pi/4)])
[sqrt(2) sqrt(2)]
```

Exercise 1.1

1. For each of the following complex numbers, determine its modulus and argument giving your answer in exact form and confirm your answer by using an appropriate routine on your calculator.

- | | | |
|---------------------|----------------------|--------------------|
| (a) $1 + \sqrt{3}i$ | (b) $-1 - \sqrt{3}i$ | (c) $\sqrt{3} - i$ |
| (d) $-2 + 2i$ | (e) $4i$ | (f) $-6i$ |

2. Express in algebraic polar form ($r \operatorname{cis} \theta$):

- | | | |
|--------------------|---------------|----------------------|
| (a) $1 + 2i$ | (b) $-3 + 4i$ | (c) $(3/5) + (4/5)i$ |
| (d) $\sqrt{3} + i$ | (e) 4 | (f) $-3i$ |

3. Express in exact algebraic Cartesian form ($a + bi$):

- | | | |
|------------------------------------|-------------------------------------|-------------------------------------|
| (a) $2 \operatorname{cis} (\pi/2)$ | (b) $3 \operatorname{cis} (-\pi/4)$ | (c) $2 \operatorname{cis} (5\pi/6)$ |
| (d) $[3, -\pi/2]$ | (e) $[\sqrt{2}, 3\pi/4]$ | (f) $[5, 5\pi/6]$ |

4. For each z given below, express \bar{z} in algebraic Cartesian and algebraic polar form:

- | | | |
|------------------|-------------------|------------------|
| (a) $z = 2 + 3i$ | (b) $z = -1 - 4i$ | (c) $z = 3 - 5i$ |
|------------------|-------------------|------------------|

5. The complex number z has modulus r and argument θ , Find r and $\tan \theta$ if (a is real):

- | | | | |
|-------------------|------------------|------------------|-------------------|
| (a) $z = a + 2ai$ | (b) $z = 1 - ai$ | (c) $z = a - 2i$ | (d) $z = 1/a + i$ |
|-------------------|------------------|------------------|-------------------|

1.2 Operations on Complex Numbers in Polar Form

1.2.1 Product and quotient of two complex numbers

- Let $z_1 = r_1 \text{cis } \theta_1$ and $z_2 = r_2 \text{cis } \theta_2$.

Then:

$$\begin{aligned} z_1 z_2 &= [r_1 \text{cis } \theta_1] \cdot [r_2 \text{cis } \theta_2] \\ &= r_1 r_2 [\cos \theta_1 + i \sin \theta_1][\cos \theta_2 + i \sin \theta_2] \cdot \\ &= r_1 r_2 [\cos \theta_1 \cos \theta_2 - \sin \theta_1 \sin \theta_2 + i(\cos \theta_1 \sin \theta_2 + \sin \theta_1 \cos \theta_2)] \\ &= r_1 r_2 [\cos(\theta_1 + \theta_2) + i \sin(\theta_1 + \theta_2)] \\ &= r_1 r_2 \text{cis}(\theta_1 + \theta_2 \pm 2n\pi) \quad \{ \pm 2n\pi \text{ where required to bring the argument} \\ &\quad \text{into the principal domain, } -\pi < \arg \leq \pi \} \end{aligned}$$

- By a similar process:

$$\frac{z_1}{z_2} = \frac{r_1}{r_2} \text{cis}(\theta_1 - \theta_2 \pm 2n\pi) \quad \{ \pm 2n\pi \text{ where required to bring the argument} \\ \text{into the domain, } -\pi < \arg \leq \pi \}$$

- Hence, in summary:

- $r_1 \text{cis } \theta_1 r_2 \text{cis } \theta_2 = r_1 r_2 \text{cis}(\theta_1 + \theta_2)$ and $\frac{r_1 \text{cis } \theta_1}{r_2 \text{cis } \theta_2} = \frac{r_1}{r_2} \text{cis}(\theta_1 - \theta_2)$.
- $\text{cis } \theta_1 \text{cis } \theta_2 = \text{cis}(\theta_1 + \theta_2)$ and $\frac{\text{cis } \theta_1}{\text{cis } \theta_2} = \text{cis}(\theta_1 - \theta_2)$

In each case the arguments need to be adjusted by adding or subtracting $2n\pi$ to bring the arguments into the principal domain $-\pi < \text{argument} \leq \pi$.

1.2.2 de Moivre's Theorem

- Consider $z = \text{cis } \theta$.

For any positive integer n ,

$$\begin{aligned} z^n &= [\text{cis } \theta]^n \\ &= (\text{cis } \theta)(\text{cis } \theta)(\text{cis } \theta)(\text{cis } \theta) \dots (\text{cis } \theta)(\text{cis } \theta) \quad \text{product of } n \text{ terms} \\ &= \text{cis}(n\theta) \quad \{ \text{argument adjusted as required} \} \end{aligned}$$

This result can be extended to all rational n and is known as **de Moivre's Theorem**.

- Hence, for all rational n ,

$$(|r| \text{cis } \theta)^n = |r|^n \text{cis}(n\theta) \quad \text{argument adjusted as required.}$$

- If $z = |r| \text{cis } \theta$ then $z^{-1} = (|r| \text{cis } \theta)^{-1} = \frac{1}{|r|} \text{cis}(-\theta)$.

Example 1.3

Without the use of a calculator, evaluate each of the following giving answers in *cis* form:

$$(a) 4 \operatorname{cis} (\pi/3) \times 2 \operatorname{cis} (3\pi/4) \quad (b) \frac{4 \operatorname{cis} (-5\pi/6)}{2 \operatorname{cis} (5\pi/6)}$$

Solution:

$$\begin{aligned} (a) \quad 4 \operatorname{cis} (\pi/3) \times 2 \operatorname{cis} (3\pi/4) &= 8 \operatorname{cis} (\pi/3 + 3\pi/4) \\ &= 8 \operatorname{cis} (13\pi/12) \\ &= 8 \operatorname{cis} (-11\pi/12) \quad [\text{Argument has been adjusted}] \end{aligned}$$

$$\begin{aligned} (b) \quad \frac{4 \operatorname{cis} (-5\pi/6)}{2 \operatorname{cis} (5\pi/6)} &= 2 \operatorname{cis} (-5\pi/6 - 5\pi/6) \\ &= 2 \operatorname{cis} (-5\pi/3) = 2 \operatorname{cis} (\pi/3) \quad [\text{Arg. has been adjusted}] \end{aligned}$$

Example 1.4

Given $z = 2 \operatorname{cis} (\pi/4)$, express z^{-1} and \bar{z} in exact *cis* and rectangular form.

Solution:

$$\begin{aligned} z^{-1} &= [2 \operatorname{cis} (\pi/4)]^{-1} \\ &= \frac{1}{2} \operatorname{cis} (-\pi/4) \quad \text{polar form} \\ &= \frac{\sqrt{2}}{4} (1 - i) \quad \text{rectangular form} \\ \bar{z} &= 2 \operatorname{cis} (-\pi/4) \quad \text{polar form} \\ &= \sqrt{2} (1 - i) \quad \text{rectangular form} \end{aligned}$$

Example 1.5

Express in exact *cis* form.

$$(a) (\sqrt{3} + i)^6 \quad (b) \frac{(2 - 2i)^5}{(-1 + i\sqrt{3})^4}$$

Solution:

$$(a) \quad (\sqrt{3} + i)^6 = [2 \operatorname{cis} (\pi/6)]^6 = 64 \operatorname{cis} \pi$$

$$\begin{aligned} (b) \quad \frac{(2 - 2i)^5}{(-1 + i\sqrt{3})^4} &= \frac{[2\sqrt{2} \operatorname{cis} (-\pi/4)]^5}{[2 \operatorname{cis} (2\pi/3)]^4} \\ &= \frac{128\sqrt{2} \operatorname{cis} (-5\pi/4)}{16 \operatorname{cis} (8\pi/3)} \\ &= 8\sqrt{2} \operatorname{cis} (-47\pi/12) = 8\sqrt{2} \operatorname{cis} (\pi/12) \end{aligned}$$

Exercise 1.2 *This exercise is to be completed without the use of a calculator.*

1. Express in polar form:

- | | |
|--|---|
| (a) $2 \operatorname{cis}(\pi/4) \times 3 \operatorname{cis}(\pi/3)$ | (b) $3 \operatorname{cis}(2\pi/3) \times 3 \operatorname{cis}(\pi/2)$ |
| (c) $4 \operatorname{cis}(-\pi/3) \times 5 \operatorname{cis}(-\pi/4)$ | (d) $2 \operatorname{cis}(-2\pi/3) \times 5 \operatorname{cis}(-\pi/2)$ |
| (e) $[2 \operatorname{cis}(\pi/4)]^5$ | (f) $[3 \operatorname{cis}(-2\pi/3)]^4$ |
| (g) $[3 \operatorname{cis}(\pi/3)]^{-4}$ | (h) $[4 \operatorname{cis}(-5\pi/6)]^{-3}$ |

2. Express in polar form:

- | | |
|---|--|
| (a) $\{2 \operatorname{cis}(\pi/3)\} / \{ \operatorname{cis}(\pi/4) \}$ | (b) $\{6 \operatorname{cis}(\pi/4)\} / \{3 \operatorname{cis}(\pi/3)\}$ |
| (c) $\{8 \operatorname{cis}(\pi/3)\} / \{4 \operatorname{cis}(-5\pi/6)\}$ | (d) $\{ \operatorname{cis}(-2\pi/3) \} / \{ \operatorname{cis}(5\pi/6) \}$ |
| (e) $1 / \{ \operatorname{cis}(\pi/3) \}$ | (f) $9 / \{3 \operatorname{cis}(-\pi/2)\}^3$ |
| (g) $4 / \{2 \operatorname{cis}(5\pi/6)\}^{-3}$ | (h) $5 / \{2 \operatorname{cis}(-3\pi/4)\}^{-4}$ |

 3. Given z , express \bar{z} and z^{-1} in rectangular form:

- | | | |
|-------------------------------------|------------------------------------|---|
| (a) $2 \operatorname{cis}(\pi/3)$ | (b) $3 \operatorname{cis}(-\pi/4)$ | (c) $4 \operatorname{cis}(3\pi/4)$ |
| (d) $5 \operatorname{cis}(-5\pi/6)$ | (e) $2 \operatorname{cis}(0)$ | (f) $1 / \{2 \operatorname{cis}(\pi/2)\}$ |

4. Express each of the following in polar and rectangular form:

- | | | | |
|--------------------------|--------------------|-------------------------|---------------------------|
| (a) $(1+i)^6$ | (b) $(1-i)^5$ | (c) $(1+i\sqrt{3})^5$ | (d) $(-\sqrt{3}-i)^6$ |
| (e) $(1-i\sqrt{3})^{-6}$ | (f) $(-2+2i)^{-4}$ | (g) $(\sqrt{3}-i)^{-5}$ | (h) $(-1-i\sqrt{3})^{-4}$ |

5. Express each of the following in polar and rectangular form:

- | | |
|--|---|
| (a) $(2+2i)^3 \times (1+i)^{-4}$ | (b) $\frac{(-\sqrt{3}-i)^6}{(1+i)^2(\sqrt{3}-i)^3}$ |
| (c) $\{2 \operatorname{cis}(\pi/3)\}^5 / \{2 \operatorname{cis}(\pi/4)\}^4$ | (d) $\{3 \operatorname{cis}(-\pi/2)\}^3 / \{ \operatorname{cis}(\pi) \}^4$ |
| (e) $\frac{\{ \operatorname{cis}(-\pi/4) \}^4 \{2 \operatorname{cis}(\pi/3)\}^3}{\{4 \operatorname{cis}(-3\pi/4)\}^2}$ | (f) $\frac{\{2 \operatorname{cis}(-5\pi/6)\}^4}{\{2 \operatorname{cis}(\pi/2)\}^2 \{3 \operatorname{cis}(\pi/4)\}^2}$ |
| (g) $\frac{a \operatorname{cis}(\pi/3) b \operatorname{cis}(-\pi/3)}{\{81 \operatorname{cis}(\pi/2)\}^{1/2}}$ | (h) $\left[\frac{a^2 \operatorname{cis}(\pi/8)}{\{b^2 \operatorname{cis}(-2\pi/3)\} \{25 \operatorname{cis}(-17\pi/24)\}} \right]^{1/2}$ |

 6. Given $w = 1 + (1/\sqrt{3})i$ and $z = 2 \operatorname{cis}(\pi/4)$, express each of the following in polar and rectangular form:

- | | | | |
|-----------------|-----------------|---------------|---|
| (a) $i^4 w$ | (b) w^4 / i^3 | (c) iwz^2 | (d) $(iz)^{-4}$ |
| (e) z^4 / w^5 | (f) $i(z/w)^5$ | (g) $w^6 z^4$ | (h) $w^6 z^{4k}$ for $k \in \mathbb{Z}^+$ |

 7. Let $w = a \operatorname{cis} \alpha$ and $z = b \operatorname{cis} \beta$.

- (a) Find \bar{w} and \bar{z} .
- (b) Prove that $\bar{w} \times \bar{z} = \overline{w \times z}$.
- (c) Prove that $\bar{w} + \bar{z} = \overline{w + z}$.

1.3 Argand Diagrams

- On an Argand Diagram (plane), a complex number can either be represented by a *point* or a *directed line segment*. The choice being determined by the context of the investigation or the problem.

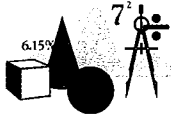

Hands On Task 1.1

In this task, we will investigate the geometrical properties of complex numbers.

- Plot on an Argand diagram the line segment representing $z = 2 \operatorname{cis}(\pi/4)$.
 - Plot on the same diagram the line segments representing \bar{z} , iz and z^{-1} .
 - Make conjectures regarding the geometrical (or transformational) relationships between the line segment representations of z , \bar{z} , iz and z^{-1} . For example: "In an Argand diagram, the line segment representing \bar{z} is the reflection of the line segment representing z about the Real axis (x -axis)."
 - Investigate the transformational relationship between $|z|$ and $|\bar{z}|$, $|iz|$ and $|z^{-1}|$.
 - Investigate the relationship between $\arg(z)$ and $\arg(\bar{z})$, $\arg(iz)$ and $\arg(z^{-1})$.
- Repeat Question 1 for other complex numbers in polar form to determine if the conjectures you made and relationships you investigated are true in general.
- Consider $a = 2 + 3i$ and $b = 2 - 2i$.
 - Plot on the same diagram the line segments representing a , b and $a + b$.
 - Does $a + b$ obey the parallelogram rule (as in vectors)?
 - Investigate with other pairs of complex numbers.

1.3.1 Geometrical Properties of Complex Numbers

- The table below summarises the transformational relationship between $z = r \operatorname{cis} \theta$, \bar{z} , iz , and z^{-1} ; z and zw ; z and z/w where $w = u \operatorname{cis} \alpha$.

	Modulus	Argument	Transformational Relationship
\bar{z}	r	$-\theta$	Reflection about the x -axis.
iz	r	$\theta + \pi/2$	Rotation anti-clockwise by $\pi/2$ radians.
z^{-1}	$1/r$	$-\theta$	Enlargement with factor $1/r$ then reflection about the x -axis.
zw	ur	$\theta + \alpha$	Enlargement with factor u then rotation anti-clockwise α radians.
z/w	r/u	$\theta - \alpha$	Enlargement with factor $1/u$ then rotation clockwise α radians.

Example 1.6

The Argand diagram below shows the point representing the complex number z where $|z| > 1$. Plot on the same diagram, the points representing the complex numbers:

- (a) \bar{z} (b) iz (c) z^2 (d) $1/z$

Solution:

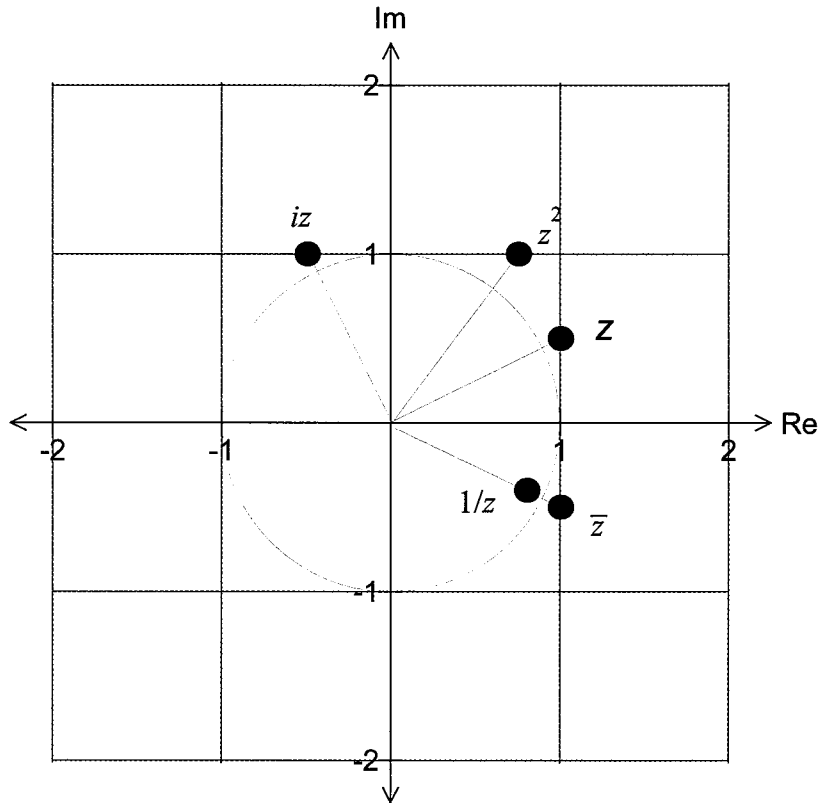

Let $z = r \operatorname{cis} \theta$.

- (a) Therefore, $\bar{z} = r \operatorname{cis} (-\theta)$.

Hence, the point representing \bar{z} is the reflection of the point representing z about the real axis.

- (b) $iz = i \times z = \operatorname{cis} (\pi/2) \times r \operatorname{cis} \theta = r \operatorname{cis} (\theta + \pi/2)$.

Hence, the vector representing iz is obtained by rotating the vector representing z , $\pi/2$ radians anticlockwise.

- (c) $z^2 = (r \operatorname{cis} \theta)^2 = r^2 \operatorname{cis} 2\theta$.

Hence, the point representing z^2 has magnitude $|z|^2$ and argument $2 \times \arg (z)$.

- (d) $1/z = (r \operatorname{cis} \theta)^{-1} = (1/r) \operatorname{cis} (-\theta)$.

Hence, the point representing $1/z$ has magnitude $1/|z|$ and argument $-\arg (z)$.
Also, since, $|z| > 1$, $1/|z| < 1$.

Exercise 1.3

1. Given that $z = 2 + 2i$, indicate on a single Argand diagram the points representing z and:
- (a) \bar{z} (b) z^{-1} (c) z^2 (d) iz (e) $-z$ (f) $z\bar{z}$

2. Given that $w = 1 - i$ and $z = 1 + i$, indicate on a single Argand diagram the points:
- (a) $w + z$ (b) $w - z$ (c) $2(w + z)$
 (d) $\overline{(w + z)}$ (e) $1/(w + z)$ (f) $(w + z)\overline{(w + z)}$

3. Given that $w = 1 + i$ and $z = 1 - i$, indicate on a single Argand diagram the points:
- (a) wz (b) w/z (c) z/w (d) \overline{wz} (e) $\overline{w/z}$ (f) iwz

4. Let $z = r \operatorname{cis} \theta$ where $0 < \theta < \pi/2$. Find in terms of r and/or θ :

- (a) $-z$ (b) \bar{z} (c) $-iz$ (d) z^2 (e) $z\bar{z}$ (f) $z + \bar{z}$
 (g) $1/z$ (h) i/z (i) $i\bar{z}$ (j) $(iz)^2$ (k) $1/(z\bar{z})$ (l) $z - \bar{z}$

5. The accompanying Argand diagram shows the point representing the complex number z where $|z| > 1$. Plot on the same diagram, the points representing the complex numbers:

- (a) \bar{z} (b) iz (c) z^2 (d) $1/z$
 (e) $z\bar{z}$ (f) $z + \bar{z}$

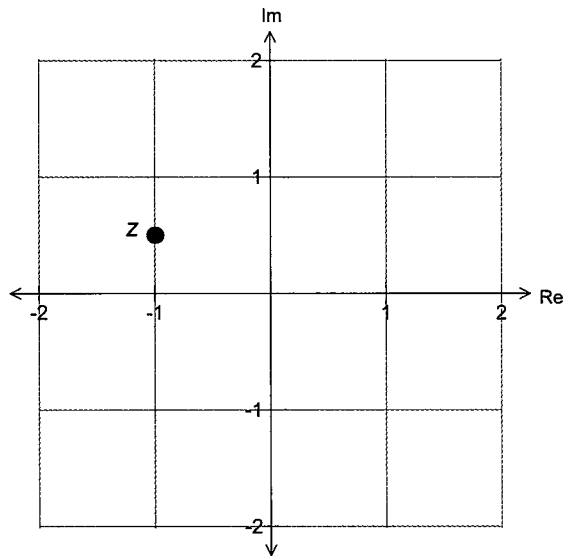

6. The accompanying Argand diagram shows the point representing the complex number z where $|z| < 1$. Plot on the same diagram, the points representing the complex numbers:

- (a) \bar{z} (b) z^2 (c) $-z$ (d) $1/z$
 (e) $z\bar{z}$ (f) $z + \bar{z}$

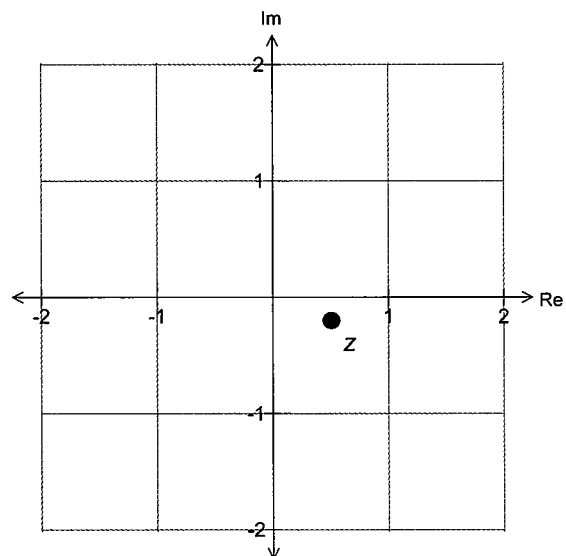

7. The accompanying Argand diagram shows the points representing the complex numbers w and z where $|w| = 0.5$ and $|z| = 1$. Plot on the same diagram, the points representing the complex numbers:

(a) $w \times z$ (b) w/z (c) z/w
 (d) $w + z$ (e) $\bar{w} + \bar{z}$ (f) $\frac{z}{w+z}$

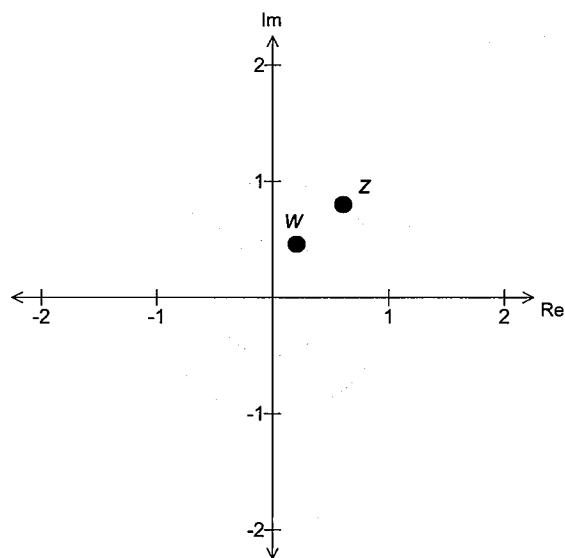

8. The accompanying Argand diagram shows the points representing the complex numbers w and z where $|w| = 0.5$ and $|z| = 1$. Plot on the same diagram, the points representing the complex numbers:

(a) $w \times z$ (b) $\bar{w} \times \bar{z}$ (c) $\overline{w \times z}$
 (d) w/z (e) $\frac{\bar{z}}{w}$ (f) $\bar{w} - \bar{z}$

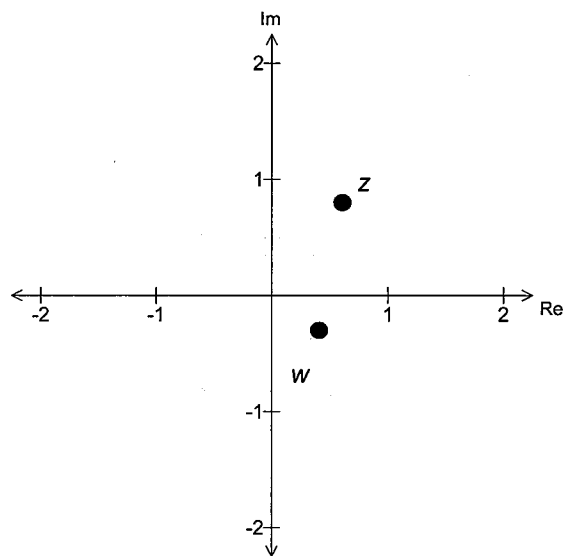

9. The accompanying Argand diagram shows the points representing the complex numbers w and z where $|w| = 2$ and $|z| = 1$. Plot on the same diagram, the points representing the complex numbers:

(a) $w \times z$ (b) $\bar{w} \times \bar{z}$ (c) $\overline{w \times z}$
 (d) w/z (e) z/w (f) $\bar{w} + \bar{z}$

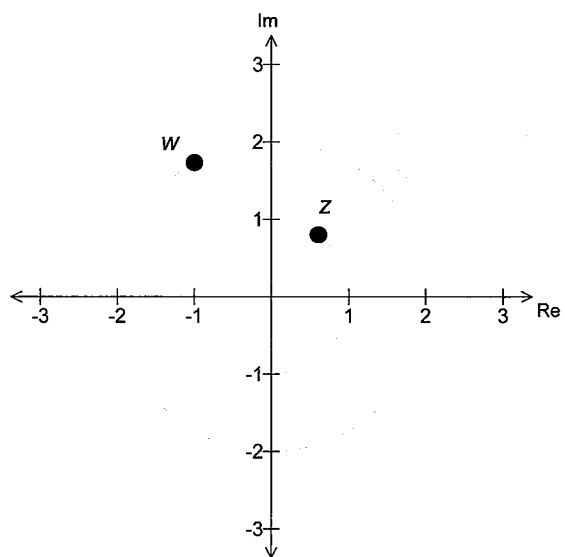

1.4 Locus

- In this section we will look at loci specified by constraints which involve complex numbers.

1.4.1 Locus involving $\text{Re}(z)$ and $\text{Im}(z)$

Example 1.7

Sketch on an Argand diagram the locus of the point $z = x + iy$ satisfying each of the following conditions. In each case give the Cartesian equation or inequality of the locus.

- (a) $\text{Re}(z) = -2$ (b) $\text{Im}(z) = \text{Re}(z)$ (c) $\text{Re}(z) + 2\text{Im}(z) > 3$ (d) $\text{Re}(z).\text{Im}(z) = 1$.

Solution:

- (a) $\text{Re}(z) = -2$

Since $z = x + iy$, $\text{Re}(z) = x$.

Hence, Cartesian equation is $x = -2$

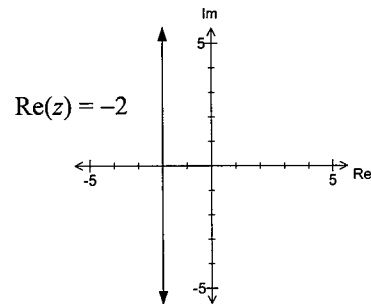

- (b) $\text{Im}(z) = \text{Re}(z)$

Since $z = x + iy$, $\text{Re}(z) = x$ and $\text{Im}(z) = y$.

Cartesian equation is $y = x$

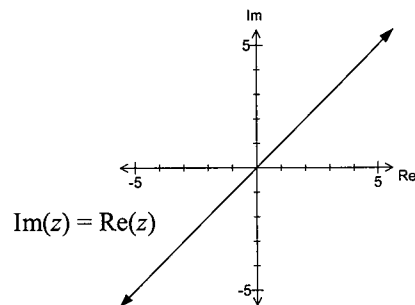

- (c) $\text{Re}(z) + 2\text{Im}(z) > 3$

Locus is indicated as the shaded region.

Cartesian inequality is $x + 2y > 3$.

[The line $x + 2y = 3$ is drawn as a dotted line.]

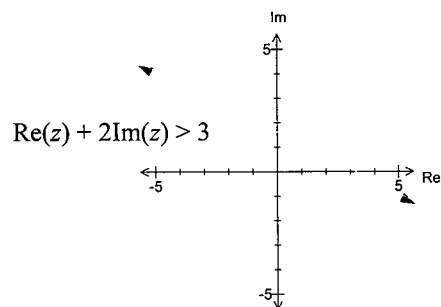

- (d) $\text{Re}(z).\text{Im}(z) = 1$

Cartesian equation is $xy = 1$

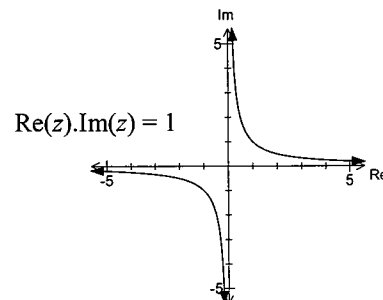

1.4.2 Locus Involving the Modulus

I. $|z - z_1| = k$ (where z_1 and k are Fixed)

- $|z - z_1|$ is interpreted geometrically as "distance" between the points representing the complex numbers z and z_1 .
- Hence, $|z - z_1| = k$ represents the locus of all points z that are at a constant distance of k to the fixed point z_1 .
- That is $|z - z_1| = k$ represents a circle with centre at z_1 and radius k .
- To derive the Cartesian form of the locus, we let:

$$z = x + yi \text{ and } z_1 = a + bi.$$

Hence $|z - z_1| = k$

becomes $|(x - a) + (y - b)i| = k$

Which gives $\sqrt{[(x - a)^2 + (y - b)^2]} = k$

Thus $(x - a)^2 + (y - b)^2 = k^2$

This represents a circle centre (a, b) with radius k .

Example 1.8

Sketch on an Argand diagram the locus of the point $z = x + yi$ satisfying the following conditions: (a) $|z - 3 + 2i| \leq 2$ (b) $|z - 3 + 2i| \leq 2$ and $|z - 3 - i| < 2$

Solution:

(a) $|z - 3 + 2i| \leq 2$

Rewriting $|z - (3 - 2i)| \leq 2$

Hence, the locus of z is a circular disc of radius 2 with centre located at $(3, -2)$.

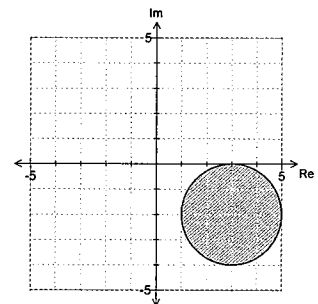

(b) $|z - 3 - i| < 2$

Rewriting $|z - (3 + i)| < 2$

The locus is the region within the disk but not on the circumference of the disk, of radius 2 with centre located at $(3, 1)$.

Hence, $|z - 3 + 2i| \leq 2$ and $|z - 3 - i| < 2$ is represented by the common area between the two discs.

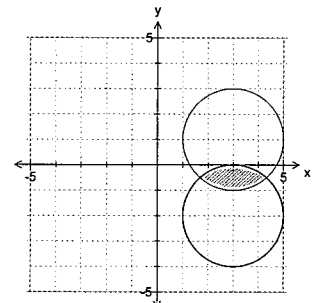

$$\text{II. } |z - z_1| = |z - z_2|$$

- This equation can be read as;

distance between z and z_1 = distance between z and z_2 .

Hence, the locus is the *perpendicular bisector* of the line segment joining z_1 to z_2 .

Example 1.9

Sketch on an Argand diagram the locus of the point $z = x + yi$ satisfying the following conditions:

(a) $|z + 2 - i| = |z + 1 - 2i|$

(b) $|z + 2 - i| \geq |z + 1 - 2i|$ and $\text{Im}(z) \leq 2$.

Solution:

(a) $|z + 2 - i| = |z + 1 - 2i|$

Rewriting $|z - (-2 + i)| = |z - (-1 + 2i)|$

The locus is the perpendicular bisector of the line joining the points $(-2, 1)$ to $(-1, 2)$.

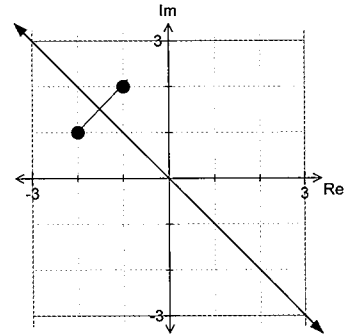

(b) $|z + 2 - i| \geq |z + 1 - 2i|$ and $\text{Im}(z) \leq 2$

The locus is indicated by the shaded region.

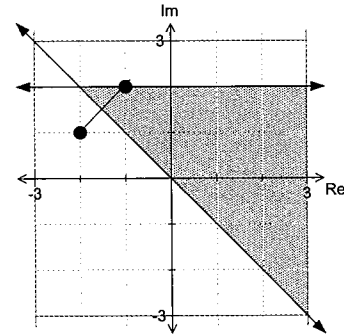

Example 1.10

Find the Cartesian equation of the locus described by:

(a) $|z - 4 + 3i| \geq 10$ (b) $|z - 2 - 3i| = |z - 3 + 3i|$

Solution:

Let $z = x + yi$.

(a) Hence, $|z - 4 + 3i| \geq 10 \Rightarrow |x + yi - 4 + 3i| \geq 10$
 $|x - 4 + (y + 3)i| \geq 10$
 Cartesian equation is $(x - 4)^2 + (y + 3)^2 \geq 100$

(b) $|z - 2 - 3i| = |z - 3 + 3i| \Rightarrow |x + yi - 2 - 3i| = |x + yi - 3 + 3i|$
 $|x - 2 + (y - 3)i| = |(x - 3) + (y + 3)i|$
 $(x - 2)^2 + (y - 3)^2 = (x - 3)^2 + (y + 3)^2$
 Cartesian equation is $2x - 12y = 5$

III. Miscellaneous Types

Example 1.11

Given that $a = 1 + i$ and $b = 5 + 7i$, sketch the locus of z , defined by:

(a) $|z - a| + |z - b| = |a - b|$

(b) $|z - a| + |a - b| = |z - b|$

(c) $|z + a| + |z + b| = |a - b|$

Solution:

(a) $|z - (1 + i)| + |z - (5 + 7i)| = |(1 + i) - (5 + 7i)|$

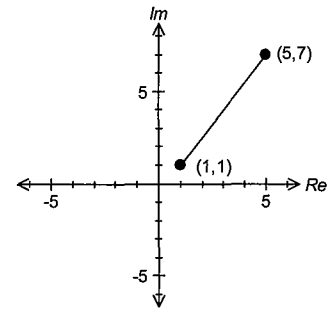
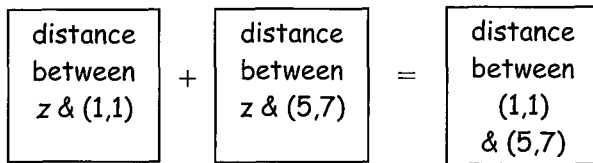

Hence, z must be a point on the line segment joining $(1, 1)$ to $(5, 7)$.

(b) $|z - (1 + i)| + |(1 + i) - (5 + 7i)| = |z - (5 + 7i)|$

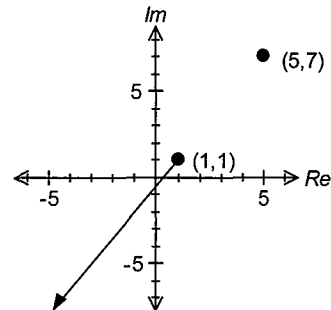
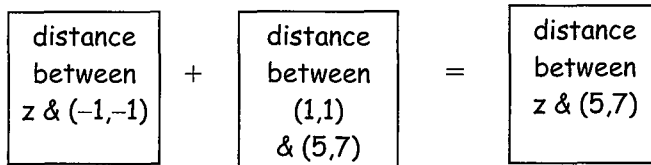

Hence, z must be a point beyond the point $(1, 1)$ on the line segment joining $(1, 1)$ to $(5, 7)$.

(c) Rewrite $|z + (1 + i)| + |z + (5 + 7i)| = |(1 + i) - (5 + 7i)|$ as:

$$|z - (-1 - i)| + |z - (-5 - 7i)| = |(-1 - i) - (-5 - 7i)|$$

$$|z - (-1 - i)| + |z - (-5 - 7i)| = |(1 + i) - (5 + 7i)|$$

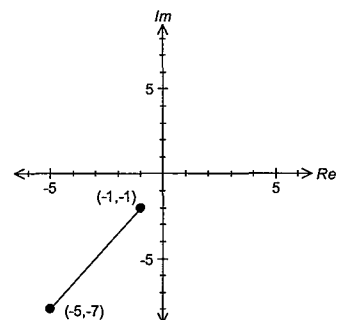
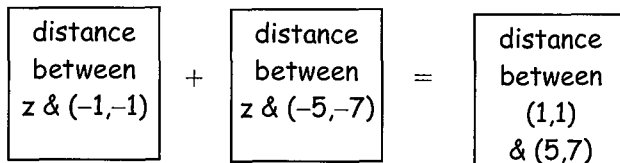

Hence, z must be a point on the line segment joining $(-1, -1)$ to $(-5, -7)$.

Note:

The distance between $(1, 1)$ and $(5, 7)$ is identical to the distance between $(-1, -1)$ and $(-5, -7)$.

1.4.3 $\text{Arg}(z) = \theta$ (θ is Constant)

- For $z = x + yi$, with $\text{arg}(z) = \theta$, then, $\tan \theta = y/x$.
Rewriting, $y = x \tan \theta$.
But since (x, y) is located only in one particular quadrant, the locus is a **half-line with equation $y = x \tan \theta$, in the quadrant containing (x, y)** .
- Hence, $\text{arg}(z) = \theta$ gives a *half line* with an end point tending to $(0, 0)$ inclined at angle θ to the positive real axis.
- Similarly it can be shown that $\text{arg}(z - z_1) = \theta$ gives a half-line with an endpoint tending to z_1 inclined at an angle θ to the positive real axis.

Example 1.12

Sketch on an Argand diagram the locus of the point $z = x + yi$ satisfying the following conditions:

- (a) $\text{arg}(z) = -5\pi/6$ (b) $\pi/6 \leq \text{arg}(z) \leq \pi/3$ and $2 \leq |z| \leq 4$ (c) $\text{arg}(z + 1) \leq \pi/3$

Solution:

(a) $\text{arg}(z) = -5\pi/6$

Locus of z is a half-line with end point tending to $(0, 0)$ inclined at an angle of $-5\pi/6$ to the real axis.

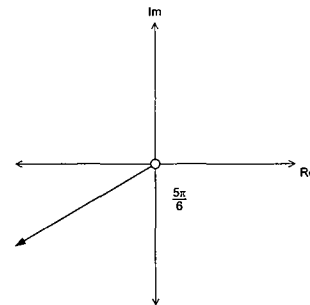

(b) $\pi/6 \leq \text{arg}(z) \leq \pi/3$ and $2 \leq |z| \leq 4$

The locus is indicated as the shaded region trapped between the two half-lines inclined at angles of $\pi/6$ and $\pi/3$ respectively, with the real axis and the two circles centred at the origin of radii 2 and 4 respectively.

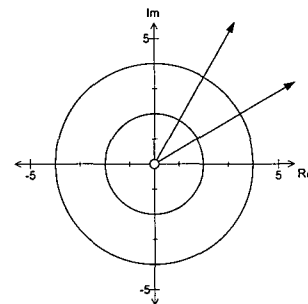

(c) $\text{arg}(z + 1) \leq \pi/3$

Rewriting, $\text{arg}[z - (-1 + 0i)] \leq \pi/3$.

Locus is indicated as the shaded region with boundaries, the half-line with end-point tending to $(-1, 0)$ inclined at an angle of $\pi/3$ to the real axis.

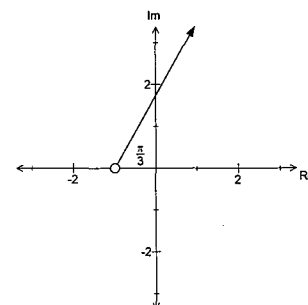

1.4.4 Locus in General

- Some loci may best be drawn after rewriting the constraints in Cartesian form.

Example 1.13

Rewrite in Cartesian form:

(a) $\text{Im}[(z - i)/(z + i)] = 1$ (b) $z + \bar{z} = z\bar{z}$.

Hence sketch the locus of z for each.

Solution:

(a) $\text{Im}\left[\frac{x + (y-1)i}{x + (y+1)i}\right] = 1$

Make the denominator real:

$$\text{Im}\left[\frac{x + (y-1)i}{x + (y+1)i} \times \frac{x - (y+1)i}{x - (y+1)i}\right] = 1$$

$$\text{Im}\left[\frac{x^2 + (y^2 - 1) + \frac{-2x}{x^2 + (y+1)^2}i}{x^2 + (y+1)^2}\right] = 1$$

$$\begin{aligned} \text{Hence, } \frac{-2x}{x^2 + (y+1)^2} &= 1 \\ x^2 + 2x + (y+1)^2 &= 0 \\ (x+1)^2 + (y+1)^2 &= 1 \end{aligned}$$

Therefore, the locus of z is a circle with centre at $(-1, -1)$ and radius 1.

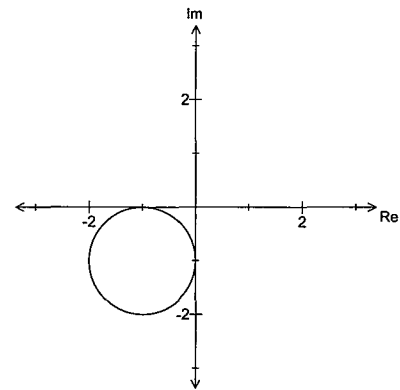

(b) $z + \bar{z} = z\bar{z}$

Substitute $z = x + yi$ and $\bar{z} = x - yi$:

$$(x + yi) + (x - yi) = (x + yi)(x - yi)$$

$$2x = x^2 + y^2$$

$$x^2 - 2x + y^2 = 0$$

$$(x - 1)^2 + y^2 = 1$$

Hence, locus of z is a circle with centre $(1, 0)$ and radius 1.

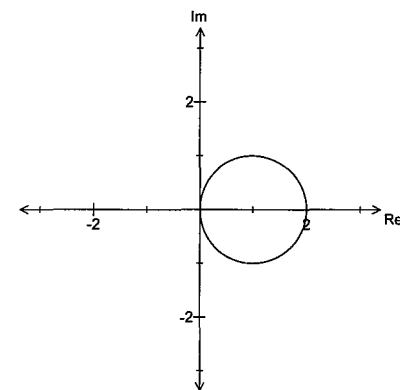

Exercise 1.4

1. Indicate on separate Argand diagrams, the locus of the point z satisfying:

- | | |
|---|---|
| (a) $\operatorname{Re}(z) = 5$ | (b) $\operatorname{Im}(z) = -3$ |
| (c) $\operatorname{Re}(z) + \operatorname{Im}(z) = 5$ | (d) $\operatorname{Re}(z) \cdot \operatorname{Im}(z) = 3$ |
| (e) $[\operatorname{Re}(z)]^2 + [\operatorname{Im}(z)]^2 = 4$ | (f) $4 \operatorname{Re}(z) = \operatorname{Im}(z)$ |
| (g) $ z - 2 = 4$ | (h) $ z - 1 - i = 2$ |
| (i) $ z - 2 - 3i = 2$ | (j) $ z + 1 + 2i = 4$ |
| (k) $ z - 1 = z - 1 - i $ | (l) $ z + 2 + i = z - 2 + 3i $ |
| (m) $ (z - i)/(z - 1) = 1$ | (n) $ (z - 1 - 2i)/(z + 1 + 4i) = 1$ |

2. For each of the constraints above, determine its Cartesian form.

3. Given that $a = 2i$ and $b = -4i$, sketch the locus of the point z such that:

- | | |
|-----------------------------------|-----------------------------------|
| (a) $ z - a + z - b = a - b $ | (b) $ z - a + a - b = z - b $ |
| (c) $ z - b + a - b = z - a $ | |

4. Given that $a = -2 + i$ and $b = 4 + 5i$, sketch the locus of the point z such that:

- | | |
|-----------------------------------|-----------------------------------|
| (a) $ z - a + z - b = a - b $ | (b) $ z - b + a - b = z - a $ |
| (c) $ z + a + z - b = a + b $ | |

5. Given that $a = -2 + 2i$ and $b = 3 - 4i$, sketch the locus of the point z such that:

- | | |
|-----------------------------------|-----------------------------------|
| (a) $ z - a + z - b = a - b $ | (b) $ z + a + z + b = a - b $ |
| (c) $ z - a + z + b = a + b $ | |

6. Indicate on separate Argand diagrams, the locus of the point z satisfying:

- | | |
|---------------------------------|----------------------------------|
| (a) $\arg(z) = \pi/5$ | (b) $\arg(z) = -\pi/4$ |
| (c) $\arg(z - 1 + 2i) = 5\pi/6$ | (d) $\arg(z + 1 - 2i) = -3\pi/4$ |
| (e) $\arg(\bar{z}) = \pi/3$ | (f) $\arg(\bar{z}) = -\pi/4$ |

7. Sketch the following regions in the Argand plane:

- | | |
|--------------------------------------|------------------------------------|
| (a) $2 \leq z \leq 5$ | (b) $2 < z - 5 + 5i < 4$ |
| (c) $ z + i \leq z - 4i $ | (d) $ z + 1 - 3i < z + 2 + 4i $ |
| (e) $\pi/4 \leq \arg(z) \leq 5\pi/6$ | (f) $\arg(z) < -\pi/3$ |
| (g) $0 \leq \arg(z + i) \leq 2\pi/3$ | (h) $-2\pi/3 \leq \arg(z - 1 + i)$ |

8. Sketch the following regions in the Argand plane:

- | | |
|--|---|
| (a) $ z \leq 3$ and $\operatorname{Re}(z) \geq -2$ | (b) $ z - 1 \leq 2$ and $\operatorname{Im}(z) \leq 1$ |
| (c) $ z \leq 5$ and $\pi/6 \leq \arg(z) \leq \pi/2$ | (d) $2 \leq z \leq 5$ and $-5\pi/6 \leq \arg(z) \leq \pi/6$ |
| (e) $ z - 1 - i \leq 2$ and $ z - 1 - i \leq z - 1 + i $ | |
| (f) $ z + 1 + i \leq z - 1 - i $ and $\arg(z) \leq -\pi/4$ | |

9. Determine the Cartesian form for each of the following constraints and hence sketch the locus of z (k is a constant):

- | | |
|--|--|
| (a) $\operatorname{Im}(z + z^{-1}) = 0$ | (b) $\operatorname{Re}[z - (1/z)] = 0$ |
| (c) $\operatorname{Im}[z - 1 + (4/z)] = 0$ | (d) $(z + 2i)/(z - 2) = ki$ |
| (e) $z = k(2 + 5i) + 3i$ | (f) $z - i = kzi$ |
| (g) $\operatorname{Re}(z) = z $ | (h) $\operatorname{Im}(\bar{z}) = z $ |
| (i) $ z - i = 2 z + 1 $ | (j) $ z - 1 + i = 3 z + 1 - 2i $ |

10. Given that $|z - 1 + i| \leq 1$, find the minimum and maximum values for :
 (a) $|z|$ (b) $\arg(z)$.
11. Given that $|z - 3 - 4i| \leq 5$, find:
 (a) the largest value for p and the smallest value for q such that $p < |z| \leq q$
 (b) the largest value for a and the smallest value for b such that $a < \arg(z) < b$.
12. Given that $|z - i| \leq 1$ and $0 \leq \arg(z) \leq \pi/4$, find:
 (a) the largest value for p and the smallest value for q such that $p < |z| \leq q$
 (b) the largest value for a and the smallest value for b such that $a < \arg(z) < b$.
13. Given that $|z - 1 + i| \leq 2$ and $\operatorname{Re}(z) \geq 1$, find the minimum and maximum values for :
 (a) $|z|$ (b) $\arg(z)$.
14. Define the locus of z in each of the following Argand diagrams:

(a)

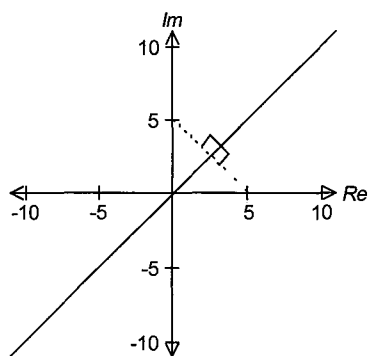

(b)

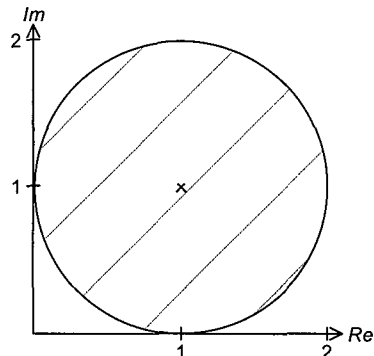

(c)

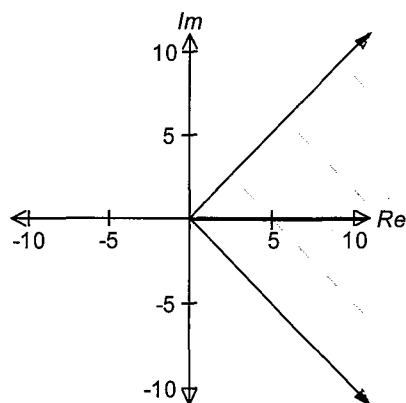

(d)

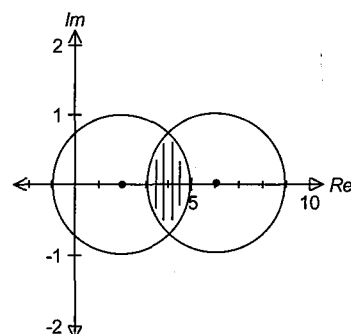

(e)

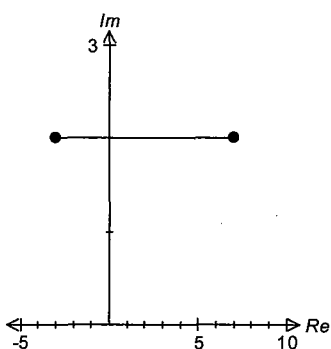

(f)

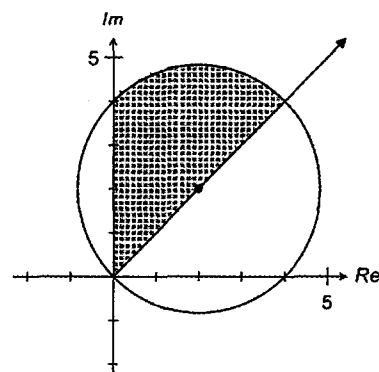

02 Complex Numbers II

2.1 The Fundamental Theorem of Algebra

- Any polynomial of degree $n \in \mathbb{Z}^+$ will have exactly n complex roots. The proof of this theorem is beyond the scope of this book.
- That is, a polynomial of degree 10 will have exactly 10 complex roots, some of which may be wholly real.

2.1.1 Roots of Complex Numbers

- Consider the equation $z^n = x + yi$ where n is a positive integer. By the Fundamental Theorem of Algebra, this equation will yield n complex solutions for z . These solutions are called the n -th roots for z .
- A procedure of determining the n -th root of a complex number is demonstrated in the examples that follow.

Example 2.1

Without the use of a calculator, solve, $z^2 = i$ giving your answers in Cartesian form.

Solution:

Rewriting i in *cis* form:
$$z^2 = cis\left(\frac{\pi}{2} + 2k\pi\right) \quad k \in \mathbb{Z}$$

Hence:
$$z = \left[cis\left(\frac{\pi}{2} + 2k\pi\right) \right]^{\frac{1}{2}}$$

Using de Moivre's Theorem:
$$z = cis\left(\frac{\pi}{4} + \frac{2k\pi}{2}\right) \quad k \in \mathbb{Z}$$

By the Fundamental Theorem of Algebra, the equation will have two roots.

For $k = 0$:
$$z = cis\left(\frac{\pi}{4}\right) = \frac{\sqrt{2}}{2} + \frac{\sqrt{2}}{2}i$$

For $k = 1$:
$$\begin{aligned} z &= cis\left(\frac{\pi}{4} + \frac{2\pi}{2}\right) = cis\left(\frac{5\pi}{4}\right) = cis\left(-\frac{3\pi}{4}\right) \\ &= -\frac{\sqrt{2}}{2} - \frac{\sqrt{2}}{2}i. \end{aligned}$$

Notes:

- The complex number i is written in *cis* form with a generalised argument. There are an infinite number of arguments that correspond to the complex number i .
- Regardless of how many integer values of k are used, there will only be at most two distinct roots.

Example 2.2

Without the use of a calculator, solve, $z^6 = -1$ giving your answers in *cis* form. Plot the roots on an Argand Plane, and comment on their relative locations.

Solution:

Rewriting in *cis* form: $z^6 = cis(\pi + 2k\pi) \quad k \in \mathbb{Z}$

Hence: $z = [cis(\pi + 2k\pi)]^{\frac{1}{6}}$

Using de Moivre's Theorem: $z = cis\left(\frac{\pi}{6} + \frac{2k\pi}{6}\right) \quad k \in \mathbb{Z}$

Hence, the roots are:

$$\begin{aligned} z_0 &= cis\left(\frac{\pi}{6}\right) \\ z_1 &= cis\left(\frac{\pi}{6} + \frac{2\pi}{6}\right) = cis\left(\frac{\pi}{2}\right) \\ z_2 &= cis\left(\frac{\pi}{6} + \frac{4\pi}{6}\right) = cis\left(\frac{5\pi}{6}\right) \\ z_3 &= cis\left(\frac{\pi}{6} + \frac{6\pi}{6}\right) = cis\left(\frac{7\pi}{6}\right) = cis\left(-\frac{5\pi}{6}\right) \\ z_4 &= cis\left(\frac{\pi}{6} + \frac{8\pi}{6}\right) = cis\left(\frac{9\pi}{6}\right) = cis\left(-\frac{\pi}{2}\right) \\ z_5 &= cis\left(\frac{\pi}{6} + \frac{10\pi}{6}\right) = cis\left(\frac{11\pi}{6}\right) = cis\left(-\frac{\pi}{6}\right) \end{aligned}$$

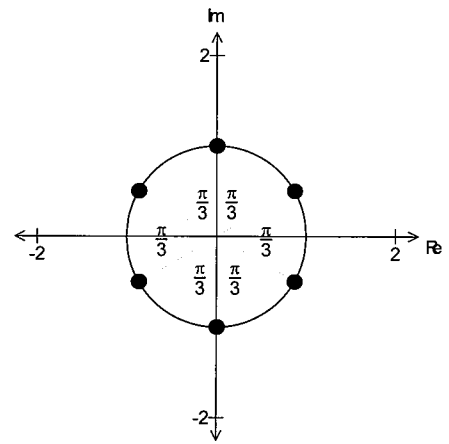

- The six roots of -1 are located at the vertices of a regular hexagon inscribed within a circle centred at $(0, 0)$ of radius 1.
- The roots are separated from each other by angles of constant size, which in this case is $\frac{2\pi}{6} \equiv \frac{\pi}{3}$ radians.

Notes:

- Note that the first root is determined by applying de Moivre's Theorem to the principal argument of -1 in *cis* form.
- The subsequent roots are separated from each other by an angle of $\frac{2\pi}{6}$.

The angular separation between the roots correspond to $\frac{2\pi}{n}$ where n is the number of roots.

- Treating the roots as vectors, clearly $z_0 + z_1 + z_2 + z_3 + z_4 + z_5 = 0$. That is, the sum of all the roots is always zero.

Alternative Solution to $z^6 = -1$:

Rewrite -1 in *cis* form: $-1 = cis \pi$

Using de Moivre's Theorem, one root is $z = cis\left(\frac{\pi}{6}\right)$

As there are six roots and the arguments of these roots differ by $\frac{2\pi}{6}$ radians.

The other roots are:

$$z_1 = cis\left(\frac{\pi}{6} + \frac{2\pi}{6}\right) = cis\left(\frac{\pi}{2}\right)$$

$$z_2 = cis\left(\frac{\pi}{6} + \frac{4\pi}{6}\right) = cis\left(\frac{5\pi}{6}\right)$$

$$z_3 = cis\left(\frac{\pi}{6} + \frac{6\pi}{6}\right) = cis\left(\frac{7\pi}{6}\right) = cis\left(-\frac{5\pi}{6}\right)$$

$$z_4 = cis\left(\frac{\pi}{6} + \frac{8\pi}{6}\right) = cis\left(\frac{9\pi}{6}\right) = cis\left(-\frac{\pi}{2}\right)$$

$$z_5 = cis\left(\frac{\pi}{6} + \frac{10\pi}{6}\right) = cis\left(\frac{11\pi}{6}\right) = cis\left(-\frac{\pi}{6}\right)$$

2.1.2 Formalising the method to determine the n -th roots of a number.

• To solve $z^n = x + yi$:

• Let $x + yi = r cis \theta$ where θ is the principal argument of $x + yi$.

• Rewrite equation as $z^n = r cis (\theta + 2k\pi)$

• Then, using de Moivre's Theorem,

the n th roots are given by $z_n = r^{\frac{1}{n}} cis\left(\frac{\theta}{n} + \frac{2k\pi}{n}\right) \quad k \in \mathbb{Z}$

• Alternatively:

• First root is $r^{\frac{1}{n}} cis \frac{\theta}{n}$.

• Difference between the arguments of the roots $\alpha = \frac{2\pi}{n}$.

• The roots are: $z_n = r^{\frac{1}{n}} cis\left(\frac{\theta}{n} + \frac{2k\pi}{n}\right) \quad k \in \mathbb{Z}$

• The n -th roots of z are located at the vertices of a regular inscribed n -gon.

The circumscribing circle is centred at $(0, 0)$ and has radius equal to $|z|^{\frac{1}{n}}$.

The arguments of the roots differ by $\frac{2\pi}{n}$ radians.

• The sum of all the n -th roots is always zero.

Exercise 2.1

- Without the use of a calculator, solve each of the following equations, giving your answers in *cis* form. In each case plot the roots on an Argand plane.

(a) $z^3 = -1$	(b) $z^3 = -8$	(c) $z^4 = -4$
(d) $z^5 = 1$	(e) $z^5 = 32$	(f) $z^6 = 64$
- Solve each of the following equations, giving your answers in rectangular form. In each case plot the roots on an Argand plane.

(a) $z^4 = i$	(b) $z^5 = -i$	(c) $z^4 = 1 + i$
(d) $z^5 = 1 + \sqrt{3}i$	(e) $z^6 + 1 + \sqrt{3}i = 0$	(f) $8z^3 + 27 = 0$
- If w , z and 1 are the cube roots of 1, show that $w = z^2$ and $w^2 = z$. Plot these roots on an Argand plane, and show using the parallelogram rule of addition, that $1 + w + z = 0$.
- Solve the equation $z^6 = 1$.
 Show that the roots of the equation may be written as $1, w, w^2, w^3, w^4, w^5$, where w is the root with the smallest positive argument.
 Verify that $1 + w + w^2 + w^3 + w^4 + w^5 = 0$.
- w is a complex number represented on an Argand diagram as a point on a circle centred at $(0, 0)$ with radius 1. Given that $\arg(w) = 2\pi/3$, find in rectangular form, w, w^2 and w^3 . State the equation for which these numbers are its roots.
- On an Argand diagram, the roots of an equation are represented as the five vertices of an inscribed regular pentagon, the circle having centre $(0, 0)$. If one vertex is the point $(-3, 0)$, find the roots of the equation in polar form and the equation.
- On an Argand diagram, the roots of an equation are represented as the six vertices of an inscribed regular hexagon, the circle having centre $(0, 0)$. If one vertex is the point $(1, \sqrt{3})$, find the roots of the equation in polar form and the equation.
- On an Argand diagram, the roots of an equation are represented as the eight vertices of an inscribed regular octagon, the circle having centre $(0, 0)$. If one vertex is the point $(1, -1)$, find the roots of the equation in *cis* form and the equation.
- Find the least positive integer n , so that *cis* $(3\pi/5)$ is a solution to the equation $z^n = -1$. For this value of n , find all solutions to $z^n + 1 = 0$, in *cis* form.
- Without using your CAS/Graphic Calculator, solve, giving all roots in exact form:

(a) $(z^3 - 1)(z^2 + z + 1) = 0$	(b) $(z^4 - 1)(z^2 + 4) = 0$
(c) $(z^3 + i)(z^2 + z + 1) = 0$	(d) $(z^3 - i)(z^3 + 8i) = 0$

2.2 Complex Numbers and Trigonometry

- Representing complex numbers in polar form invariably leads to a link between complex numbers and trigonometry. As it often happens in mathematics, transfer occurs between the different branches of mathematics, and in this case, we can transfer the techniques developed in complex numbers to work out problems in trigonometry.

- Let $z = \cos \theta + i \sin \theta$.

$$\begin{aligned} \text{Hence, } z^n &= (\cos \theta + i \sin \theta)^n \\ z^n &= \cos n\theta + i \sin n\theta \end{aligned} \quad \text{I}$$

$$\begin{aligned} \text{Similarly, } \frac{1}{z^n} &= z^{-n} = (\cos \theta + i \sin \theta)^{-n} \\ &= \cos(-n\theta) + i \sin(-n\theta) \\ \frac{1}{z^n} &= \cos n\theta - i \sin n\theta \end{aligned} \quad \text{II}$$

$$\begin{array}{l} \text{I + II;} \\ \text{I - II;} \end{array} \quad \begin{array}{l} \boxed{z^n + \frac{1}{z^n} = 2 \cos n\theta} \\ \boxed{z^n - \frac{1}{z^n} = 2i \sin n\theta} \end{array} \quad \Rightarrow \quad \begin{array}{l} \boxed{\cos n\theta = \frac{1}{2} \left(z^n + \frac{1}{z^n} \right)} \\ \boxed{\sin n\theta = \frac{1}{2i} \left(z^n - \frac{1}{z^n} \right)} \end{array}$$

- By using the Binomial Theorem and the above relationships we can rework some common trigonometric identities.

Example 2.3 *Expressing powers of sine/cosine as multiple angles.*

Find the expansion for $\left(z + \frac{1}{z}\right)^4$. Hence, prove that $\cos^4 \theta = \frac{1}{8} [\cos 4\theta + 4 \cos 2\theta + 3]$.

Solution:

$$\begin{aligned} \left(z + \frac{1}{z}\right)^4 &= z^4 + 4z^3 \left(\frac{1}{z}\right) + 6z^2 \left(\frac{1}{z}\right)^2 + 4z \left(\frac{1}{z}\right)^3 + \left(\frac{1}{z}\right)^4 \\ &= \left(z^4 + \frac{1}{z^4}\right) + 4 \left(z^2 + \frac{1}{z^2}\right) + 6 \end{aligned}$$

$$\text{But } \left(z + \frac{1}{z}\right) = 2 \cos \theta, \quad \left(z^2 + \frac{1}{z^2}\right) = 2 \cos 2\theta \quad \text{and} \quad \left(z^4 + \frac{1}{z^4}\right) = 2 \cos 4\theta.$$

$$\begin{aligned} \text{Hence } [2 \cos \theta]^4 &= 2 \cos 4\theta + 4[2 \cos 2\theta] + 6 \\ \cos^4 \theta &= \frac{1}{8} [\cos 4\theta + 4 \cos 2\theta + 3] \end{aligned}$$

Example 2.4 Expressing sine/cosine of multiple angles in terms of powers of sine/cosine

(a) Expand $(\cos \theta + i \sin \theta)^5$.

(b) By using de Moivre's Theorem and by equating real and imaginary parts show that

$$\cos 5\theta = 16 \cos^5 \theta - 20 \cos^3 \theta + 5 \cos \theta$$

and

$$\sin 5\theta = 16 \sin^5 \theta - 20 \sin^3 \theta + 5 \sin \theta.$$

(c) Hence, solve $16x^5 - 20x^3 + 5x - 1 = 0$, giving all roots in trigonometric form.

Solution:

$$\begin{aligned} \text{(a) } (\cos \theta + i \sin \theta)^5 &= \cos^5 \theta + 5 \cos^4 \theta (i \sin \theta) + 10 \cos^3 \theta (i \sin \theta)^2 + 10 \cos^2 \theta (i \sin \theta)^3 \\ &\quad + 5 \cos \theta (i \sin \theta)^4 + (i \sin \theta)^5 \\ &= \cos^5 \theta - 10 \cos^3 \theta \sin^2 \theta + 5 \cos \theta \sin^4 \theta \\ &\quad + i [5 \cos^4 \theta \sin \theta - 10 \cos^2 \theta \sin^3 \theta + \sin^5 \theta] \end{aligned} \quad [1]$$

(b) Using de Moivre's Theorem:

$$(\cos \theta + i \sin \theta)^5 = \cos 5\theta + i \sin 5\theta \quad [2]$$

Equating the real parts in [1] and [2]:

$$\begin{aligned} \cos 5\theta &= \operatorname{Re}[(\cos \theta + i \sin \theta)^5] \\ &= \cos^5 \theta - 10 \cos^3 \theta \sin^2 \theta + 5 \cos \theta \sin^4 \theta \\ &= \cos^5 \theta - 10 \cos^3 \theta (1 - \cos^2 \theta) + 5 \cos \theta (1 - \cos^2 \theta)^2 \\ &= 16 \cos^5 \theta - 20 \cos^3 \theta + 5 \cos \theta \end{aligned}$$

Similarly:

$$\begin{aligned} \sin 5\theta &= \operatorname{Im}[(\cos \theta + i \sin \theta)^5] \\ &= 5 \cos^4 \theta \sin \theta - 10 \cos^2 \theta \sin^3 \theta + \sin^5 \theta \\ &= 16 \sin^5 \theta - 20 \sin^3 \theta + 5 \sin \theta \end{aligned}$$

$$\text{(c) Rewrite equation as } 16x^5 - 20x^3 + 5x = 1 \quad [3]$$

Substitute $x = \sin \theta$,

$$[3] \text{ becomes } 16 \sin^5 \theta - 20 \sin^3 \theta + 5 \sin \theta = 1 \quad [4]$$

But from part (b) $16 \sin^5 \theta - 20 \sin^3 \theta + 5 \sin \theta = \sin(5\theta)$.

Hence, [4] becomes $\sin(5\theta) = 1$

Therefore

$$\begin{aligned} 5\theta &= \pi/2, 5\pi/2, 9\pi/2, 13\pi/2, 17\pi/2 \\ \theta &= \pi/10, \pi/2, 9\pi/10, 13\pi/10, 17\pi/10 \end{aligned}$$

Hence, roots of equation $16x^5 - 20x^3 + 5x - 1 = 0$ are:

$$\begin{aligned} x &= \sin(\pi/10), \sin(\pi/2), \sin(9\pi/10), \sin(13\pi/10) \text{ and } \sin(17\pi/10) \\ &= \sin(\pi/10), \sin(\pi/2), \sin(13\pi/10) \end{aligned}$$

Note:

- In part (c), the roots of the polynomial equation $16x^5 - 20x^3 + 5x - 1 = 0$ are expressed in trigonometric form. Alternatively, if we had substituted $x = \cos \theta$, the solutions would be $\cos(0)$, $\cos(2\pi/5)$ and $\cos(4\pi/5)$.

Exercise 2.2

1. Find the expansion for $\left(z - \frac{1}{z}\right)^4$.

Use this expansion and the identities $z^n + \frac{1}{z^n} = 2 \cos n\theta$ and $z^n - \frac{1}{z^n} = 2i \sin n\theta$

to prove that $\sin^4 \theta = \frac{1}{8} [\cos 4\theta - 4 \cos 2\theta + 3]$.

2. Use either of (or both) the identities $z^n + \frac{1}{z^n} = 2 \cos n\theta$ and $z^n - \frac{1}{z^n} = 2i \sin n\theta$ and

de Moivre's Theorem to prove the following:

(a) $\sin^5 \theta = [\sin 5\theta - 5 \sin 3\theta + 10 \sin \theta]/16$

(b) $\sin^6 \theta = -[\cos 6\theta - 6 \cos 4\theta + 15 \cos 2\theta - 10]/32$

(c) $\sin^2 \theta \cos^3 \theta = [2 \cos \theta - \cos 3\theta - \cos 5\theta]/16$

(d) $\sin 5\theta + \sin \theta = 2 \sin 3\theta \cos 2\theta$

(e) $\cos 5\theta + \cos 3\theta = 2 \cos 4\theta \cos \theta$

3. Use de Moivre's Theorem to prove that $\sin 3\theta = -4 \sin^3 \theta + 3 \sin \theta$.

Hence, use this result to solve $-4x^3 + 3x = 1$, giving the roots in trigonometric form.

4. Use de Moivre's Theorem to prove that $\cos 3\theta = 4 \cos^3 \theta - 3 \cos \theta$.

Hence, use this result to solve $8x^3 - 6x - 1 = 0$, giving the roots in trigonometric form.

5. Use de Moivre's Theorem to express $\cos 6\theta$ in terms of powers of $\cos \theta$.

Hence, use your result to solve, giving answers in trigonometric form:

(a) $64x^6 - 96x^4 + 36x^2 - 2 = 0$

(b) $64x^3 - 96x^2 + 36x - 2 = 0$

6. (a) Use de Moivre's Theorem to express $\cos 5\theta$ in terms of $\cos \theta$.

(b) Show that $\cos 5\theta - 1 = (\cos \theta - 1)(16 \cos^4 \theta + a \cos^3 \theta + b \cos^2 \theta + c \cos \theta + d)$, giving the values of a, b, c and d .

(c) For the values of a, b, c and d in part (b), solve $16t^4 + at^3 + bt^2 + ct + d = 0$, giving all roots in trigonometric form.

7. If $z = cis \theta$ verify that $\tan \theta = \frac{z - z^{-1}}{i(z + z^{-1})}$.

Use this result to prove that:

(a) $\cos 2\theta = \frac{1 - \tan^2 \theta}{1 + \tan^2 \theta}$

(b) $\sin 2\theta = \frac{2 \tan \theta}{1 + \tan^2 \theta}$

2.3 Complex Numbers in Exponential Form

- Euler's identity states that $e^{ix} = \cos x + i \sin x$.
It allows complex numbers to be expressed in exponential form.

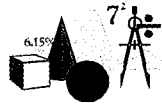

Hands On Task 2.2

In this task, we will investigate the use of the Maclaurin's expansion to develop Euler's identity $e^{ix} = \cos x + i \sin x$.

The Maclaurin's series expansion for $f(x)$ is given by

$$f(x) = f(0) + f'(0)x + \frac{f''(0)}{2!}x^2 + \frac{f'''(0)}{3!}x^3 + \dots + \frac{f^{(r)}(0)}{r!}x^r + \dots,$$

$$\text{where } r! = r \times (r-1) \times (r-2) \times (r-3) \times \dots \times 3 \times 2 \times 1.$$

- Write the series expansion for each of the following up to and including the term in x^7 .
(a) $f(x) = e^x$ (b) $f(x) = \sin x$ (c) $f(x) = \cos x$
- The Maclaurin's series expansion is valid only under certain conditions. We will now extend its validity to complex numbers.

Use the series expansion for e^x to write the series expansion for e^{ix} .

Hence, use the expansions for $\sin x$ and $\cos x$ to express e^{ix} in terms of $\cos x$ and $\sin x$.

2.3.1 Working with Complex Numbers in Exponential Form

- Hands On Task 2.2 investigated a procedure to develop Euler's identity:

$$e^{ix} = \cos x + i \sin x.$$

From this, we can write, $r e^{ix} = r (\cos x + i \sin x) = r \operatorname{cis} x$.

- We can now express complex numbers in the following ways:

$z = x + yi$	Rectangular/Cartesian form
$= r \operatorname{cis} \theta$	Polar form
$= r e^{i\theta}$	Exponential form

where $x = r \cos \theta$ and $y = r \sin \theta$.

- If $z = r \operatorname{cis} \theta = r e^{i\theta}$, then $\bar{z} = r \operatorname{cis} (-\theta) = r e^{-i\theta}$.
- If $w = r_1 e^{i\alpha}$ and $z = r_2 e^{i\beta}$, then $wz = r_1 r_2 e^{i(\alpha+\beta)}$ and $\frac{w}{z} = \frac{r_1}{r_2} e^{i(\alpha-\beta)}$.
- If $z = r e^{i\theta}$, then $z^n = (r e^{i\theta})^n = r^n e^{in\theta}$.

The identities in Section 2.2 can now be expanded to:

$$\begin{aligned} \bullet \cos n\theta &= \frac{1}{2} \left(z^n + \frac{1}{z^n} \right) = \frac{1}{2} \left(e^{in\theta} + \frac{1}{e^{in\theta}} \right) \\ \bullet \sin n\theta &= \frac{1}{2i} \left(z^n - \frac{1}{z^n} \right) = \frac{1}{2i} \left(e^{in\theta} - \frac{1}{e^{in\theta}} \right) \end{aligned}$$

These two identities allow us to express $\cos n\theta$ and $\sin n\theta$ in exponential form!

Example 2.5

Express in exact exponential form: (a) $z = -1$ (b) $z = -1 + i$

Solution:

$$(a) \quad z = -1 = \operatorname{cis} \pi = e^{i\pi}$$

$$(b) \quad z = -1 + i = \sqrt{2} \operatorname{cis} (3\pi/4) = \sqrt{2} e^{i \frac{3\pi}{4}}$$

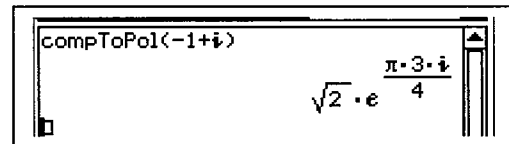

Note:

- Euler's Identity $e^{i\pi} = -1$, links the four concept numbers in the development of Mathematics; -1 , π , e and $i \equiv \sqrt{-1}$.
- Remember that your Mathematics Teacher is number $-e^{i\pi}$.

Example 2.6

Express in exact rectangular form: (a) $e^{-i \frac{\pi}{4}}$ (b) $e^{1+i \frac{\pi}{3}}$

Solution:

$$(a) \quad e^{-i \frac{\pi}{4}} = \operatorname{cis} (-\pi/4) = \frac{\sqrt{2}}{2} (1 - i)$$

$$\begin{aligned} (b) \quad e^{1+i \frac{\pi}{3}} &= e^1 \times e^{i \frac{\pi}{3}} \\ &= e \operatorname{cis} (\pi/3) = e \left(\frac{1}{2} + i \frac{\sqrt{3}}{2} \right) \end{aligned}$$

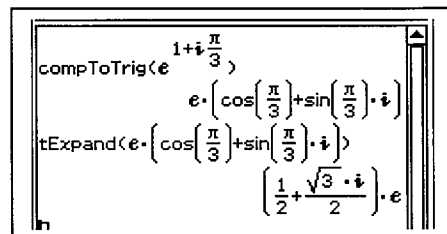

Example 2.7

If $w = e^{i\pi}$ and $z = 2e^{i\frac{\pi}{3}}$, find in the polar form: (a) wz (b) w/z (c) $\bar{w} \times \bar{z}$

Solution:

$$\begin{aligned} \text{(a)} \quad wz &= e^{i\pi} \times 2e^{i\frac{\pi}{3}} \\ &= 2e^{i\frac{4\pi}{3}} \\ &= 2 \operatorname{cis}\left(\frac{4\pi}{3}\right) \\ &= 2 \operatorname{cis}\left(-\frac{2\pi}{3}\right) \end{aligned}$$

$$\begin{aligned} \text{(b)} \quad w/z &= \frac{e^{i\pi}}{2e^{i\frac{\pi}{3}}} \\ &= \frac{1}{2}e^{i\frac{2\pi}{3}} \\ &= \frac{1}{2} \operatorname{cis}\left(\frac{2\pi}{3}\right) \end{aligned}$$

$$\begin{aligned} \text{(c)} \quad \bar{w} \times \bar{z} &= e^{-i\pi} \times 2e^{-i\frac{\pi}{3}} \\ &= 2e^{-i\frac{4\pi}{3}} \\ &= 2 \operatorname{cis}\left(-\frac{4\pi}{3}\right) \\ &= 2 \operatorname{cis}\left(\frac{2\pi}{3}\right) \end{aligned}$$

Example 2.8

Use the exponential form of the complex number to prove that $\operatorname{cis}(\alpha + \beta) = \operatorname{cis} \alpha \operatorname{cis} \beta$.

Solution:

Let $e^{i\alpha} = \operatorname{cis} \alpha$ and $e^{i\beta} = \operatorname{cis} \beta$.

Clearly, $e^{i\alpha} \times e^{i\beta} = \operatorname{cis} \alpha \times \operatorname{cis} \beta$.

But, $e^{i\alpha} \times e^{i\beta} = e^{i(\alpha + \beta)}$.

Since, $e^{i(\alpha + \beta)} = \operatorname{cis}(\alpha + \beta)$, hence, $\operatorname{cis}(\alpha + \beta) = \operatorname{cis} \alpha \operatorname{cis} \beta$

Note:

- The relationship $\operatorname{cis}(\alpha + \beta) = \operatorname{cis} \alpha \operatorname{cis} \beta$ was proved earlier in Section 1.2 of Chapter 1.

Example 2.9

Use the relationship $\sin n\theta = \frac{1}{2i} \left(e^{in\theta} - \frac{1}{e^{in\theta}} \right)$ and $\cos n\theta = \frac{1}{2} \left(e^{in\theta} + \frac{1}{e^{in\theta}} \right)$

to prove that $8 \sin^4 \theta = \cos 4\theta - 4 \cos 2\theta + 3$.

Solution:

$$\text{Clearly } \sin \theta = \frac{1}{2i} \left(e^{i\theta} - \frac{1}{e^{i\theta}} \right).$$

Hence,

$$\begin{aligned} \sin^4 \theta &= \left[\frac{1}{2i} \left(e^{i\theta} - \frac{1}{e^{i\theta}} \right) \right]^4 \\ &= \left(\frac{1}{2i} \right)^4 \left[(e^{i\theta})^4 - 4(e^{i\theta})^3 \left(\frac{1}{e^{i\theta}} \right) + 6(e^{i\theta})^2 \left(\frac{1}{e^{i\theta}} \right)^2 - 4(e^{i\theta}) \left(\frac{1}{e^{i\theta}} \right)^3 + \left(\frac{1}{e^{i\theta}} \right)^4 \right] \\ &= \frac{1}{16} \left[\left(e^{i4\theta} + \frac{1}{e^{i4\theta}} \right) - 4 \left(e^{i2\theta} + \frac{1}{e^{i2\theta}} \right) + 6 \right] \\ &= \frac{1}{16} [2 \cos 4\theta - 4 \times 2 \cos 2\theta + 6] \end{aligned}$$

Therefore, $8 \sin^4 \theta = \cos 4\theta - 4 \cos 2\theta + 3$

Note:

- This proof was required in Question 1 of Exercise 2.2, using the cis form of the complex number.

Example 2.10

Solve $e^{x+yi} = -3$ where x and y are real numbers. Hence, determine $\ln(-3)$.

Solution:

$$\begin{aligned} e^{x+yi} = -3 &\Rightarrow e^{x+yi} = 3 \times (-1) \\ e^{x+yi} &= e^{\ln 3} \times e^{i(2k+1)\pi} & k \in \mathbb{Z} \\ e^{x+yi} &= e^{\ln 3 + i(2k+1)\pi} \end{aligned}$$

Comparing real and imaginary parts:

$$\begin{aligned} x &= \ln 3 \\ y &= (2k+1)\pi & k \in \mathbb{Z} \end{aligned}$$

Therefore $e^{\ln 3 + i(2k+1)\pi} = -3$

Expressed in logarithmic form:

$$\ln(-3) = \ln 3 + (2k+1)\pi \quad k \in \mathbb{Z}$$

Exercise 2.3

- Express in exact exponential form:
 (a) $z = 2 \operatorname{cis}(\pi)$ (b) $z = 5 \operatorname{cis}(3\pi/4)$ (c) $z = 3 \operatorname{cis}(-\pi/6)$ (d) $z = \sqrt{2} \operatorname{cis}(-2\pi/3)$
- Express in exact exponential form:
 (a) $z = 1$ (b) $z = i$ (c) $z = 1 + \sqrt{3}i$ (d) $z = -2 - 2i$ (e) $z = 3 - \sqrt{3}i$
- Express in exact polar form: (a) $e^{i\pi/6}$ (b) $e^{-i\frac{5\pi}{6}}$ (c) $e^{1-i\frac{\pi}{4}}$ (d) $e^{-2+i\frac{\pi}{3}}$
- Express in exact Cartesian form: (a) $e^{i\frac{2\pi}{3}}$ (b) $e^{i\frac{3\pi}{4}}$ (c) $e^{-1-i\frac{\pi}{3}}$ (d) $e^{2+i\frac{5\pi}{6}}$
- If $w = -1 + i$ and $z = \sqrt{3} - i$, find in exact exponential form:
 (a) z^2 (b) wz (c) \bar{w} (d) \bar{z} (e) $\bar{w}w$ (f) \bar{w}^2 (g) $\bar{w}\bar{z}$ (h) \overline{wz}
- If $w = 2 + 2i$ and $z = \sqrt{3} - 3i$, find in exact exponential form:
 (a) \bar{z}^2 (b) \bar{z}^2 (c) $\frac{1}{\bar{w}}$ (d) $\overline{\left(\frac{1}{w}\right)}$ (e) $\frac{\bar{z}}{\bar{w}}$ (f) $\overline{\left(\frac{z}{w}\right)}$
- If $w = \sqrt{2}e^{-i\frac{\pi}{2}}$ and $z = \frac{e^{i\frac{2\pi}{3}}}{2}$, find in the exact polar form:
 (a) wz (b) $\frac{w}{z}$ (c) $\bar{w} \times \bar{z}$ (d) $\overline{w \times z}$ (e) $\frac{\bar{w}}{\bar{z}}$ (f) $\overline{\left(\frac{\bar{w}}{\bar{z}}\right)}$
- If $w = r_1 e^{i\alpha}$ and $z = r_2 e^{i\beta}$, prove that: (a) $wz = r_1 r_2 e^{i(\alpha+\beta)}$ (b) $\frac{w}{z} = \frac{r_1}{r_2} e^{i(\alpha-\beta)}$
- Use the exponential form of the complex number to prove that $\operatorname{cis}(\alpha - \beta) = \frac{\operatorname{cis} \alpha}{\operatorname{cis} \beta}$.
- Use Euler's formula $e^{ix} = \cos x + i \sin x$ to prove de Moivre's Theorem $(\operatorname{cis} x)^n = \operatorname{cis} nx$.
- Use the relationship $\sin n\theta = \frac{1}{2i} \left(e^{in\theta} - \frac{1}{e^{in\theta}} \right)$ and $\cos n\theta = \frac{1}{2} \left(e^{in\theta} + \frac{1}{e^{in\theta}} \right)$ to prove that:
 (a) $8 \cos^4 \theta = \cos 4\theta + 4 \cos 2\theta + 3$
 (b) $32 \cos^2 \theta \sin^4 \theta = \cos 6\theta - 2 \cos 4\theta - \cos 2\theta + 2$
 (c) $64 \cos^3 \theta \sin^4 \theta = \cos 7\theta - \cos 5\theta - 3 \cos 3\theta + 3 \cos \theta$
 (d) $16 \cos^4 \theta \sin \theta = \sin 5\theta + 3 \sin 3\theta + 2 \sin \theta$

12. Solve $e^{x+yi} = k$ where x and y are real numbers for :
 (a) $k = -1$ (b) $k = -2$ (c) $k = 2$ (d) $k = i$ *(e) $k = 1 + i$
13. Without the use of a graphic/CAS calculator, solve for a and b given that a and b are real.
 (a) $\ln(-1) = a + bi$, (b) $\ln(-2) = a + bi$ (c) $\ln(-3) = a + bi$.
- *14. Given $\ln(-k^2) = a + bi$, solve for a and b given that k , a and b are real.
15. Given that $z = 2e^{i\frac{\pi t}{4}}$, sketch on an Argand diagram the graph of $z = 2e^{i\frac{\pi t}{4}}$.
 Hence, or otherwise, find the maximum value of $\text{Re}(z)$ and the minimum value of $\text{Im}(z)$.
16. Given that $z = e^{-1-i\frac{\pi t}{3}}$, sketch on an Argand diagram the graph of $z = e^{-1-i\frac{\pi t}{3}}$.
 Hence, or otherwise, find the minimum value of $\text{Re}(z)$ and the maximum value of $\text{Im}(z)$.
17. Given that z is a complex number, prove that $e^{z+2\pi i} = e^z$.
18. Given that z is a complex number, prove that $(e^z)^n = e^{nz}$ where n is an integer.
19. Given that z is a complex number, prove that $\overline{e^z} = e^{\bar{z}}$.
20. Given that w and z are complex numbers, prove that $e^w e^z = e^{w+z}$ and $\frac{e^w}{e^z} = e^{w-z}$

03 The Factor and Remainder Theorems

3.1 The Factor Theorem

- The degree of a polynomial in x is determined by the power of its highest x term.
For example, $x^5 - 3x^4 + 5$ is a polynomial of degree 5.
- Consider the polynomial $f(x)$.
 - If $f(k) = 0$, then $(x - k)$ is a linear factor of the polynomial $f(x)$.
 - Conversely if $(x - k)$ is a factor of the polynomial $f(x)$ then $f(k) = 0$.
- $x = k$ is called a *root* or *zero* of the polynomial $f(x)$ if $f(k) = 0$.
- By systematically “guessing” the zeros, the factor theorem enables us to factorise polynomials of any degree.

Example 3.1

The polynomial $f(x) \equiv 3x^4 + 7x^3 + ax^2 + bx - 2$ is exactly divisible by $(x - 1)(x + 2)$.
Without the use of a calculator:

- (a) find the values of a and b . (b) express the polynomial as product of its linear factors.

Solution:

(a) Since $(x - 1)$ and $(x + 2)$ are factors of $f(x)$

$$f(1) = 0 \text{ and } f(2) = 0$$

$$f(1) = 0 \quad \Rightarrow \quad a + b = -8 \quad \text{(I)}$$

$$f(-2) = 0 \quad \Rightarrow \quad 2a - b = 5 \quad \text{(II)}$$

Solving (I) and (II) simultaneously:

$$a = -1 \text{ and } b = -7.$$

Write $3x^4 + 7x^3 - x^2 - 7x - 2 \equiv (x - 1)(x + 2)Q(x)$

$$\equiv (x^2 + x - 2)Q(x)$$

By inspection $3x^4 + 7x^3 - x^2 - 7x - 2 \equiv (x^2 + x - 2)(3x^2 + 4x + 1)$

$$\equiv (x - 1)(x + 2)(x + 1)(3x + 1)$$

Notes:

- $Q(x)$ is polynomial of degree 2 and is determined using a method of inspection first introduced in Section 3.3 of Chapter 3 of the book *Mathematics Methods Units 1 & 2*.
- Alternatively, a method involving a process of polynomial division may be used. See Example 3.6.

Example 3.2

Without the use of a calculator, factorise completely $f(x) \equiv 2x^4 - 5x^3 - 24x^2 - 7x + 10$.

Solution:

The integer zeros of $f(x)$ must be factors of 10.

$$\text{Try } x = 1 \quad f(1) \neq 0$$

$$\text{Try } x = -1 \quad f(-1) = 0 \quad \Rightarrow (x + 1) \text{ is a factor.}$$

$$\text{Try } x = 2 \quad f(2) \neq 0$$

$$\text{Try } x = -2 \quad f(-2) = 0 \quad \Rightarrow (x + 2) \text{ is a factor.}$$

$$\begin{aligned} \text{Rewrite} \quad 2x^4 - 5x^3 - 24x^2 - 7x + 10 &\equiv (x + 1)(x + 2) Q(x) \\ &\equiv (x^2 + 3x + 2) Q(x) \end{aligned}$$

$$\begin{aligned} \text{By inspection:} \quad 2x^4 - 5x^3 - 24x^2 - 7x + 10 &\equiv (x^2 + 3x + 2)(2x^2 - 11x + 5) \\ &\equiv (x + 1)(x + 2)(2x - 1)(x - 5) \end{aligned}$$

Example 3.3

Without the use of a calculator, solve $x^5 + x^4 - 6x^3 - 2x^2 + 4x = 0$.

Solution:

$$x^5 + x^4 - 6x^3 - 2x^2 + 4x \equiv x(x^4 + x^3 - 6x^2 - 2x + 4)$$

$$\text{Let } f(x) \equiv x^4 + x^3 - 6x^2 - 2x + 4$$

$$f(-1) = 0 \quad \Rightarrow (x + 1) \text{ is a factor.}$$

$$f(2) = 0 \quad \Rightarrow (x - 2) \text{ is a factor.}$$

$$\begin{aligned} \text{Hence,} \quad x^4 + x^3 - 6x^2 - 2x + 4 &\equiv (x + 1)(x - 2) Q(x) \\ &\equiv (x^2 - x - 2) Q(x) \\ &\equiv (x^2 - x - 2)(x^2 + 2x - 2) \\ &\equiv (x + 1)(x - 2)(x^2 + 2x - 2) \end{aligned}$$

Hence equation becomes:

$$\begin{aligned} x(x + 1)(x - 2)(x^2 + 2x - 2) &= 0 \\ \Rightarrow x &= -1, 0, 2, \frac{-2 \pm \sqrt{(-2)^2 - 4(1)(-2)}}{2} \\ &= -1, 0, 2, -1 \pm \sqrt{3} \end{aligned}$$

Exercise 3.1 This Exercise is to be completed without the use of a calculator.

- If $(2x - 1)(3x - 1)$ is a factor of $ax^3 + x^2 + bx + 1$, find a and b .
- If $(2x - k)^2$ is a factor of $4x^3 + 40x^2 + 37x + 9$, find k .
- Given that $2x^4 - 8x^3 + 11x^2 - 20x + 15 \equiv (x - 1)(x - 3)(ax^2 + bx + c)$, find a , b and c .
- Given that $-3x^4 + 12x^3 - 5x^2 - 28x + 28 \equiv (x - 2)^2(ax^2 + bx + c)$, find a , b and c .
- Factorise each of the following.

(a) $x^4 + 10x^3 + 35x^2 + 50x + 24$	(b) $x^4 + 6x^3 + 13x^2 + 12x + 4$
(c) $x^4 - x^3 - 7x^2 + 13x - 6$	(d) $4x^4 - 4x^3 - 9x^2 + x + 2$
(e) $2x^4 - x^3 + x^2 - x - 1$	(f) $x^4 - 3x^3 + 6x^2 - 12x + 8$
- Given that $x^5 - 2x^4 + 2x^3 - 4x^2 - 3x + 6$ is exactly divisible by $x^2 + 3$, find the remaining real factors of the polynomial.
- Sketch each of the following curves. Indicate clearly all intercepts.

(a) $y = x^3 + 3x^2 - 24x + 28$	(b) $y = (x^2 - 4x + 4)(x^2 + 2x - 3)$
(c) $y = 2x^4 - 3x^3 - 4x^2 + 3x + 2$	(d) $y = x^4 - 13x^2 + 36$
- Solve for real values of x :

(a) $x^4 + 7x^3 + 18x^2 + 20x + 8 = 0$	(b) $x^4 - 2x^3 + 2x - 1 = 0$
(c) $3x^5 - 7x^4 - x^3 + 7x^2 - 2x = 0$	(d) $6x^5 - x^4 - 7x^3 + x^2 + x = 0$
(e) $x^4 - 2x^3 - 5x^2 + 8x + 4 = 0$	(f) $x^4 - x^3 - x^2 - x - 2 = 0$
- Solve for all real values of x , $6x^3 - x^2 - 5x + 2 = 0$. Hence, solve for all real values of x :

(a) $48x^3 - 4x^2 - 10x + 2 = 0$	(b) $6x^6 - x^4 - 5x^2 + 2 = 0$
(c) $-6x^3 - x^2 + 5x + 2 = 0$	(d) $2x^3 - 5x^2 - x + 6 = 0$
- Solve for all real values of x , $2x^4 - x^3 - 17x^2 + 16x + 12 = 0$. Hence, solve for all real values of x :

(a) $2x^4 + x^3 - 17x^2 - 16x + 12 = 0$	(b) $2x^8 - x^6 - 17x^4 + 16x^2 + 12 = 0$
(c) $12x^4 + 16x^3 - 17x^2 - x + 2 = 0$	(d) $12x^4 - 16x^3 - 17x^2 + x + 2 = 0$

3.2 The Remainder Theorem

3.2.1 Quotients and Remainders

- Consider the polynomial $f(x)$ of degree n .
If $f(x)$ is divided by a linear expression $(ax + b)$ then we can write:

$$f(x) \equiv (ax + b) Q(x) + R.$$

- $Q(x)$ is called the *quotient* and R is called the *remainder*.
 - The quotient $Q(x)$ is also a polynomial in x but of degree $(n - 1)$.
 - The remainder R is a constant.
- On the other hand if the polynomial $f(x)$ of degree n is divided by a quadratic expression $(ax^2 + bx + c)$, then we write:

$$f(x) \equiv (ax^2 + bx + c) Q(x) + R(x).$$

- The quotient $Q(x)$ is now a polynomial of degree $(n - 2)$.
- The remainder $R(x)$ is a polynomial of degree one (a linear expression).

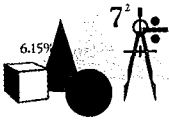

Hands On Task 3.1

In this task, we will explore a technique for dividing polynomials, to obtain the remainder.

- Consider the polynomial $x^2 + 2x + 7$.
If the polynomial is divided by $(x - 1)$, then $x^2 + 2x + 7 \equiv (x - 1) Q(x) + R$.
By substituting an appropriate value for x into $x^2 + 2x + 7 \equiv (x - 1) Q(x) + R$, find R .
What value of x did you substitute? Why?
- Consider the polynomial $2x^3 + 2x^2 - 3x + 5$. If the polynomial is divided by $(x + 1)$, then $2x^3 + 2x^2 - 3x + 5 \equiv (x + 1) Q(x) + R$. By substituting an appropriate value for x into $2x^3 + 2x^2 - 3x + 5 \equiv (x + 1) Q(x) + R$, find R .
- For each of the given polynomials and divisors, rewrite the polynomial in terms of its divisor, quotient and remainder. By substituting an appropriate value of x into the statement you have written, find the remainder in each case.

(a) $x^2 + 4x - 9$; $x + 2$	(b) $x^3 - 4x^2 - 7x + 5$; $x - 2$
(c) $-4x^3 - 5x^2 + x - 10$; $1 + x$	(d) $2x^4 - 3x^3 + 5x^2 - 10x - 1$; $2 - x$
- Review what you have done in the first three questions. Write down an algorithm (procedure) for determining the remainder when a polynomial $f(x)$ is divided by a linear expression $(ax + b)$.

3.2.2 The Remainder Theorem

- When the polynomial $f(x)$ is divided by $(ax - b)$, its **remainder** is given by $f\left(\frac{b}{a}\right)$.
 - When $f(x)$ is divided by $(ax - b)$, let the quotient be $Q(x)$ and the remainder be R . The remainder R must be a constant.
 - Clearly:

$$f(x) \equiv (ax - b)Q(x) + R$$

$$f\left(\frac{b}{a}\right) \equiv \left[a\left(\frac{b}{a}\right) - b\right]Q(x) + R$$

$$\equiv R$$
 - Hence, the remainder $R \equiv f\left(\frac{b}{a}\right)$.
 - Clearly if the remainder is 0, then $x = \frac{b}{a}$ is a zero and $(ax - b)$ is a factor.
- The remainder theorem provides a simple and efficient algorithm for determining the remainder when the divisor is a *linear* factor.
- When the *quotient* is required or when the divisor is a *non-linear polynomial*, a method whereby coefficients of terms are compared may be used. Alternatively, a procedure called *polynomial division* may be used. See Example 3.6.

Example 3.4

When $ax^3 + bx^2 - 3x + 1$ is divided by $x + 1$ and $2x - 1$, the remainders are 2 and 1 respectively. Find the values of a and b .

Solution:

Let	$f(x) \equiv ax^3 + bx^2 - 3x + 1$
Clearly	$f(-1) = 2 \quad \Rightarrow \quad -a + b = -2$
and	$f\left(\frac{1}{2}\right) = 1 \quad \Rightarrow \quad a + 2b = 12$
Hence	$a = \frac{16}{3} \quad \text{and} \quad b = \frac{10}{3}$.

Example 3.5

When $x^3 + ax^2 + bx - 1$ is divided by $(x + 1)(x - 1)$, the remainder is $(2x + 1)$. Find the values of a and b .

Solution:

Clearly	$x^3 + ax^2 + bx - 1 \equiv (x + 1)(x - 1)Q(x) + (2x + 1)$
Substitute $x = -1$	$a - b = 1$
Substitute $x = 1$	$a + b = 3$
Hence	$a = 2 \quad \text{and} \quad b = 1$.

Example 3.6

Without the use of a calculator, find the quotient and remainder when the polynomial $x^4 + 3x^3 - 2x^2 + 5x - 1$ is divided by $x - 1$.

Solution:

Let $f(x) = x^4 + 3x^3 - 2x^2 + 5x - 1$

By the Remainder Theorem: The remainder is $f(1) = 6$

Clearly $x^4 + 3x^3 - 2x^2 + 5x - 1 \equiv (x - 1)(ax^3 + bx^2 + cx + d) + 6$

Comparing coefficients and constant terms:

Comparing the x^4 terms $a = 1$

Comparing the x^3 terms $b - a = 3 \Rightarrow b = 4$

Comparing the x^2 terms $c - b = -2 \Rightarrow c = 2$

Comparing the constant terms $-d + 6 = -1 \Rightarrow d = 7$

Hence, quotient is $x^3 + 4x^2 + 2x + 7$
and the remainder is 6.

Alternative Solution:

Using the method of polynomial division.

$$\begin{array}{r}
 x^3 + 4x^2 + 2x + 7 \\
 x-1 \overline{) x^4 + 3x^3 - 2x^2 + 5x - 1} \\
 \underline{x^4 - x^3} \\
 4x^3 - 2x^2 + 5x - 1 \\
 \underline{4x^3 - 4x^2} \\
 2x^2 + 5x - 1 \\
 \underline{2x^2 - 2x} \\
 7x - 1 \\
 \underline{7x - 7} \\
 6
 \end{array}$$

Hence, quotient is $x^3 + 4x^2 + 2x + 7$ and the remainder is 6.

Example 3.7

Without the use of a calculator, find the quotient and remainder when the polynomial $2x^4 - 3x^3 + x^2 - 2x + 1$ is divided by $x^2 + x + 1$.

Solution:

Clearly the remainder is a polynomial of degree 1.

Let $2x^4 - 3x^3 + x^2 - 2x + 1 \equiv (x^2 + x + 1)(ax^2 + bx + c) + (dx + e)$

Comparing coefficients and constant terms:

Comparing the x^4 terms	$a = 2$	
Comparing the x^3 terms	$b + a = -3$	$\Rightarrow b = -5$
Comparing the x^2 terms	$c + b + a = 1$	$\Rightarrow c = 4$
Comparing the x terms	$d + b + c = -2$	$\Rightarrow d = -1$
Comparing the constant terms	$e = 1$	$\Rightarrow e = -3$

Hence, quotient is $2x^2 - 5x + 4$
and the remainder is $-x - 3$.

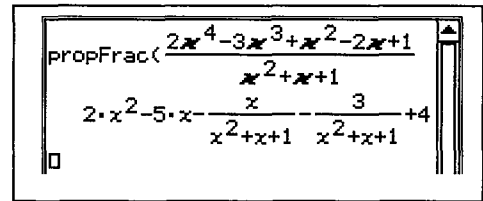

Alternative Solution:

Using the method of polynomial division.

$$\begin{array}{r}
 2x^2 - 5x + 4 \\
 x^2 + x + 1 \overline{) 2x^4 - 3x^3 + x^2 - 2x + 1} \\
 \underline{2x^4 + 2x^3 + 2x^2} \\
 -5x^3 - x^2 - 2x + 1 \\
 \underline{-5x^3 - 5x^2 - 5x} \\
 4x^2 - 3x + 1 \\
 \underline{4x^2 + 4x + 4} \\
 -x - 3
 \end{array}$$

Hence, quotient is $2x^2 - 5x + 4$ and the remainder is $-x - 3$.

Exercise 3.2

- Without the use of a calculator, find the remainder and the quotient when the given polynomial is divided by each of the accompanying expressions.

(a) $x^3 + 4x - 7$	(i) $x + 2$	(ii) $x^2 - 4$
(b) $3x^3 - 5x^2 - 8x + 12$	(i) $2x - 1$	(ii) $x^2 - x + 2$
(c) $5 - 3x + 6x^2 - 4x^3$	(i) $1 + 2x$	(ii) $(2x - 1)(x + 1)$
(d) $6x^4 - 5x^3 + 2x^2 - 5x + 10$	(i) $x - 2$	(ii) $x^2 - 4$ (iii) $2x^3 + x^2 + x - 2$
- When the polynomial $x^2 + px + q$ is divided by $x - 1$ and $x + 2$ the remainders are 5 and 5 respectively. Find the values of p and q .
- When the polynomial $x^3 + px^2 + qx + 1$ is divided by $x + 3$ and $x - 2$, the remainders are 10 and 9 respectively. Find the values of p and q .
- The polynomial $2x^3 + px^2 + q$ has a factor $(x + 1)$ and leaves a remainder of 16 when it is divided by $(x - 3)$. Find the values of p and q .
- When $x^3 - px + q$ is divided by $x^2 - 3x + 2$, the remainder is $4x - 1$. Find the values of p and q .
- When $2x^3 - 3x^2 - 10x + 1$ is divided by $x^2 - x - 6$, the remainder is $ax + b$. Find a and b .
- $3x^4 + 5x^3 + ax^2 + bx + 13$ leaves a remainder of $2x + 1$ when divided by $x^2 - 2x - 3$. Find a and b .
- $ax^3 + bx^2 - 6x + 8$ leaves a remainder of $2 - x$ when divided by $x^2 + x - 2$. Find a and b .
- When $x^5 - 7x^3 + 4x - 2$ is divided by $(x - 1)(x - 3)(x + 1)$, the remainder is $px^2 + qx + r$. Find the values of p , q and r .
- When $2x^5 - x^4 + px^3 + qx^2 + rx + 1$ is divided by $(x^2 - 1)(x - 2)$, the remainder is $2x^2 + 3x + 1$. Find the values of p , q and r .
- The polynomial $2x^3 - 3ax^2 + ax + b$ has a factor $x - 1$ and leaves a remainder of -54 when divided by $x + 2$. Find the values of a and b .
- The polynomial $ax^3 + bx^2 + 3x + 2$ has a factor $3x + 1$ and leaves a remainder of $9x - 5$ when divided by $x^2 - 1$. Find the values of a and b .

13. The polynomials $P(x)$ and $Q(x)$ are defined as follows:

$$P(x) = x^8 - 1, \quad Q(x) = x^4 + 4x^3 + ax^2 + bx + 5.$$

- (a) Show that $x - 1$ and $x + 1$ are factors of $P(x)$.
 (b) Find a and b if $Q(x)$ leaves a remainder of $2x + 3$ when it is divided by $x^2 - 1$.
 (c) With these values of a and b , find the remainder when the polynomial $4P(x) + 5Q(x)$ is divided by $x^2 - 1$.

14. Determine the values of a , b and c in the identity

$$x^4 + x^2 + x + 1 \equiv (x^2 + a)(x^2 - 1) + bx + c.$$

By using an appropriate numerical substitution or otherwise, find the remainder when 100 010 101 is divided by 9 999.

3.3 Extension to the Factor and Remainder Theorems

- In this section, we will extend the factor and remainder theorems to complex polynomials with real coefficients.
- When the complex polynomial $f(z)$ is divided by $[z - (a + bi)]$, the remainder is given by $f(a + bi)$.
- If $f(a + bi) = 0 \Leftrightarrow [z - (a + bi)]$ is a factor of $f(z)$.

Example 3.8

The polynomial $f(z) = z^3 - 1$ is divided by $(z - 1 - i)$.
 Find the remainder and the quotient.

Solution:

Rewrite $[z - 1 - i]$ as $[z - (1 + i)]$.

Hence, the remainder is $f(1 + i) \equiv (1 + i)^3 - 1 \equiv -3 + 2i$.

Let $z^3 - 1 \equiv [z - (1 + i)][z^2 + bz + c] - 3 + 2i$ where b and c are complex.

Comparing z^2 coefficients: $b - (1 + i) = 0 \Rightarrow b = 1 + i$

Comparing constant terms: $-c(1 + i) - 3 + 2i = -1$

$$c = \frac{-2 + 2i}{1 + i} = 2i$$

Hence, the quotient is $z^2 + (1 + i)z + 2i$ and the remainder is $-3 + 2i$.

3.3.1 The Complex Conjugate Root Theorem

- Let $f(x)$ be a polynomial with real coefficients.
If $a + bi$ is a root of $f(x)$, then its conjugate $a - bi$ is also a root of $f(x)$.
- That is, for a polynomial with real coefficients, the complex roots appear as conjugate pairs.
- For example, a polynomial with real coefficients of degree 9 will have at least one root which is wholly real and a maximum of four pairs of complex conjugate roots.

Example 3.9 Proof of the Complex Conjugate Root Theorem

Prove that if $a + bi$ is a root of a polynomial $f(x)$ with all real coefficients, then its conjugate $a - bi$ is also a root of $f(x)$.

Solution:

$$\text{Let } f(x) = a_n x^n + a_{n-1} x^{n-1} + a_{n-2} x^{n-2} + \dots + a_2 x^2 + a_1 x + a_0$$

Let z be a complex root of $f(x)$. That is $f(z) = 0$

$$\text{Hence, } a_n z^n + a_{n-1} z^{n-1} + a_{n-2} z^{n-2} + \dots + a_2 z^2 + a_1 z + a_0 = 0$$

Take conjugates of both sides:

$$\overline{a_n z^n + a_{n-1} z^{n-1} + a_{n-2} z^{n-2} + \dots + a_2 z^2 + a_1 z + a_0} = 0$$

$$\begin{aligned} \text{But } a_n z^n + a_{n-1} z^{n-1} + a_{n-2} z^{n-2} + \dots + a_2 z^2 + a_1 z + a_0 & \\ &= \overline{a_n z^n} + \overline{a_{n-1} z^{n-1}} + \overline{a_{n-2} z^{n-2}} + \dots + \overline{a_2 z^2} + \overline{a_1 z} + \overline{a_0} \\ &= a_n \overline{z}^n + a_{n-1} \overline{z}^{n-1} + a_{n-2} \overline{z}^{n-2} + \dots + a_2 \overline{z}^2 + a_1 \overline{z} + a_0 \\ &= a_n (\overline{z})^n + a_{n-1} (\overline{z})^{n-1} + a_{n-2} (\overline{z})^{n-2} + \dots + a_2 (\overline{z})^2 + a_1 (\overline{z}) + a_0 \end{aligned}$$

Hence:

$$a_n (\overline{z})^n + a_{n-1} (\overline{z})^{n-1} + a_{n-2} (\overline{z})^{n-2} + \dots + a_2 (\overline{z})^2 + a_1 (\overline{z}) + a_0 = 0$$

That is: $f(z) = 0 \Rightarrow f(\overline{z}) = 0$.

Example 3.10

Without the use of a calculator, verify that $(z - i)$ is a factor of $f(z) = z^4 + z^3 - 5z^2 + z - 6$ and hence express $f(z)$ as a product of all its complex factors.

Solution:

$$f(i) = i^4 + i^3 - 5i^2 + i - 6 = 0. \text{ Hence } (z - i) \text{ is a factor of } f(z).$$

By the Complex Conjugate Root Theorem, since the coefficients of $f(z)$ are all real, the conjugate of $(z - i) \equiv (z + i)$ must also be a factor.

$$\begin{aligned} \text{Hence, } z^4 + z^3 - 5z^2 + z - 6 &\equiv (z - i)(z + i)(z^2 + bz + c) \\ &\equiv (z^2 + 1)(z^2 + bz + c) \end{aligned}$$

By inspection:

$$\begin{aligned} z^4 + z^3 - 5z^2 + z - 6 &\equiv (z^2 + 1)(z^2 + z - 6) \\ &\equiv (z - i)(z + i)(z - 2)(z + 3). \end{aligned}$$

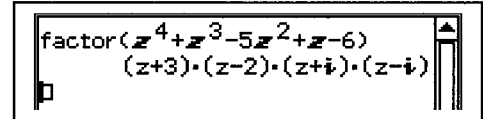

Example 3.11

Without the use of a calculator, solve $x^5 - x^4 + 13x^3 - 13x^2 + 36x - 36 = 0$, giving all roots (real and complex) in exact form.

Solution:

$$\text{Let } f(x) = x^5 - x^4 + 13x^3 - 13x^2 + 36x - 36.$$

$$f(1) = 1 - 1 + 13 - 13 + 36 - 36 = 0 \quad \Rightarrow \quad (x - 1) \text{ is a factor.}$$

Factorising by inspection:

$$x^5 - x^4 + 13x^3 - 13x^2 + 36x - 36 \equiv (x - 1)(x^4 + bx^3 + cx^2 + dx + 36)$$

$$\text{Compare } x^4 \text{ terms: } \quad b = 0$$

$$\text{Compare } x^3 \text{ terms: } \quad c = 13$$

$$\text{Compare } x^2 \text{ terms: } \quad d = 0$$

$$\begin{aligned} \text{Hence, } x^5 - x^4 + 13x^3 - 13x^2 + 36x - 36 &\equiv (x - 1)(x^4 + 13x^2 + 36) \\ &\equiv (x - 1)(x^2 + 4)(x^2 + 9) \end{aligned}$$

$$x^5 - x^4 + 13x^3 - 13x^2 + 36x - 36 = 0 \quad \Rightarrow \quad x = 1, \pm 2i, \pm 3i$$

Example 3.12

Without the use of a calculator, solve $x^7 + x^6 + x + 1 = 0$, giving all roots (real and complex) in exact form.

Solution:

$$\text{Let } f(x) = x^7 + x^6 + x + 1$$

$$f(-1) = -1 + 1 + -1 + 1 = 0 \Rightarrow (x + 1) \text{ is a factor.}$$

Factorising by inspection:

$$x^7 + x^6 + x + 1 \equiv (x + 1)(x^6 + 1)$$

$$x^7 + x^6 + x + 1 = 0 \Rightarrow x = -1 \text{ or } x^6 = -1$$

Consider $x^6 = -1$.

Rewriting in *cis* form: $x^6 = \text{cis}(\pi + 2k\pi) \quad k \in \mathbb{Z}$

By de Moivre's Theorem: $x = \text{cis}\left(\frac{\pi}{6} + \frac{2k\pi}{6}\right)$

For $k = 0$: $x = \text{cis}\left(\frac{\pi}{6}\right) = \frac{\sqrt{3}}{2} + \frac{1}{2}i$

Complex conjugate: $x = \text{cis}\left(-\frac{\pi}{6}\right) = \frac{\sqrt{3}}{2} - \frac{1}{2}i$

For $k = 1$: $x = \text{cis}\left(\frac{\pi}{2}\right) = i$

Complex conjugate: $x = \text{cis}\left(-\frac{\pi}{2}\right) = -i$

For $k = 2$: $x = \text{cis}\left(\frac{5\pi}{6}\right) = -\frac{\sqrt{3}}{2} + \frac{1}{2}i$

Complex conjugate: $x = \text{cis}\left(-\frac{5\pi}{6}\right) = -\frac{\sqrt{3}}{2} - \frac{1}{2}i$

Hence, $x^7 + x^6 + x + 1 = 0 \Rightarrow x = -1, \pm i, \frac{\sqrt{3}}{2} \pm \frac{1}{2}i, -\frac{\sqrt{3}}{2} \pm \frac{1}{2}i$

Note:

- As the coefficients are all real, the complex roots appear as conjugate pairs.
- In Example 2.2, to obtain all the six roots of $z^6 = -1$, six different values of k were required. But in this example, using the Complex Conjugate Root Theorem, only three different values of k were sufficient.

Exercise 3.3

1. Without the use of a calculator, in each of the following, verify that the second polynomial is a factor of the first polynomial. Hence factorise the first polynomial completely.

(a) $z^3 + 2z^2 + z + 2, z - i$

(b) $z^3 + 2z^2 + 4z + 8, z - 2i$

(c) $4z^3 - 4z^2 + z - 1, 2z + i$

(d) $z^3 + 2z^2 - 6z + 8, z - 1 + i$

2. Find the values of a and b , where a and b are real, such that $(z - 4i)$ is a factor of $z^3 + az^2 + bz - 64$. Hence, factorise $z^3 + az^2 + bz - 64$.
3. Find the values of a and b , where a and b are real, such that $(z - 1 - i)$ is a factor of $z^3 + az + b$. Hence, factorise $z^3 + az + b$.
4. Find the values of a and b , where a and b are real, such that $(z - 1 + 2i)$ is a factor of $z^4 - 2z^3 + 2z^2 + az + b$. Hence, solve $z^4 - 2z^3 + 2z^2 + az + b = 0$.
5. Find the values of a and b , where a and b are real, such that $(z + 2 + i)$ is a factor of $4z^4 + az^3 + 21z^2 + bz + 5$. Hence, solve $4z^4 + az^3 + 21z^2 + bz + 5 = 0$.
6. Find the values of a and b , where a and b are real, such that $(3z - i)$ is a factor of $az^4 + 18z^3 + 28z^2 + bz + 3$. Hence, solve $az^4 + 18z^3 + 28z^2 + bz + 3 = 0$.
7. Without the use of a calculator, solve for z , where z is a complex number.
- (a) $z^4 + z^2 - 2 = 0$
- (b) $z^4 + z^3 - 2z^2 - 6z - 4 = 0$
- (c) $z^4 - 4z^3 + 4z^2 - 9 = 0$
- *(d) $z^4 - 4z^3 + 9z^2 - 16z + 20 = 0$
- *8. Without the use of a calculator, solve for x , where x is a complex number.
- (a) $x^5 - x^4 + x - 1 = 0$
- (b) $x^6 - x^4 + x^2 - 1 = 0$
- (c) $x^7 - x^6 - x + 1 = 0$
- (d) $x^8 - x^6 - x^2 + 1 = 0$
- *9. $(x - i)$ and $(2x + i)$ are factors of the polynomial $4x^6 + 9x^4 + ax^2 + bx + c$ where a, b and c are real. Find the values of a, b and c .
- *10. $(x - 1 + i)$ and $(x + 1 + i)$ are factors of the polynomial $x^6 + x^5 + x^4 + ax^2 + bx + c$ where a, b and c are real. Find the values of a, b and c .

04 Functions

4.1 Review of Functions

- A function f between sets X and Y is a rule that associates *each* element in set X with a *unique* element in set Y .
 - X is called the *domain* of the function f , while Y is the *codomain* of f .
 - The set of all images of f in Y is called the *range* of f .
The range is a subset of the codomain.
- Where the domain and codomain of a function is not specified, the *natural domain* is assumed: this is the largest set that qualifies the mapping rule as a function rule. The codomain will then be the *natural range* of the function. This is the set of all images corresponding to the elements in the natural domain.
- In this book, the following notations will be used interchangeably to describe domains and ranges.
 - $\mathbb{R} \equiv (-\infty, \infty) \equiv \{x: x \in \mathbb{R}\}$
 - $\mathbb{R}^+ \equiv (0, \infty) \equiv \{x: x > 0, x \in \mathbb{R}\}$
 - $\mathbb{R}_0^+ \equiv [0, \infty) \equiv \{x: x \geq 0, x \in \mathbb{R}\}$
 - $\mathbb{R}_0^- \equiv (-\infty, 0] \equiv \{x: x \leq 0, x \in \mathbb{R}\}$
 - $\mathbb{R} - \{a\} \equiv \{x: x \neq a, x \in \mathbb{R}\}$
 - $(a, b] \equiv \{x: a < x \leq b, x \in \mathbb{R}\}$
 - The “square bracket” is used to denote a closed interval, i.e. it includes the endpoint while the “round bracket” is used to denote an open interval, i.e. it does not include the end point.

4.1.1 Onto Functions

- A function f is said to be an *onto function* if its range is identical to its codomain.

Example 4.1

Determine if each of the following functions are onto functions or otherwise.

- (a) $f(x) = x + 10$ with domain $[0, \infty)$ and codomain \mathbb{R} .
- (b) $f(x) = \ln(x)$ with domain \mathbb{R}^+ and codomain \mathbb{R} .

Solution:

- (a) Range for f is $\{x: x \geq 10, x \in \mathbb{R}\}$ which is a proper subset of the codomain \mathbb{R} .
Hence, f is not an onto function.
- (b) Range for f is \mathbb{R} which is also the codomain. Hence, f is an onto function.

4.1.2 One to One and Many to One Functions

- Where two different elements in domain of the function f are mapped to the same element in the codomain, the function is called a *many-to-one* function.
 - That is, f is a many-to-one function if $\exists a, b$ such that $a \neq b$ and $f(a) = f(b)$.
- Where no two elements in the domain of the function f are mapped to the same element in the codomain, the function is called a *one-to-one* function.
 - That is, f is a one-to-one function if $f(a) = f(b)$ then $a = b$.
 - Graphically, f is a one-to-one function if the graph of f passes the horizontal line test.
 - When a horizontal line is drawn through its graph, the line must pass through no more than one point on its graph.

Example 4.2

The graphs of the functions f and g are drawn in the accompanying diagrams. Determine with reasons if these functions are one-to-one or many-to-one functions.

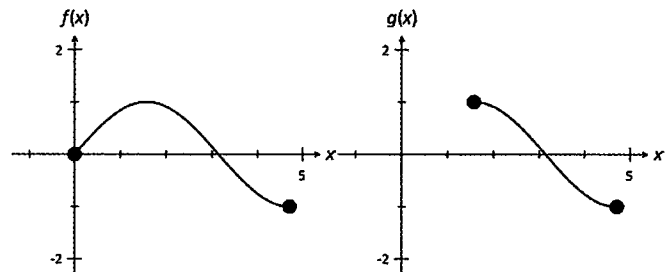

Solution:

f is a many-to-one function as there are at least two elements in the domain that map to the same image.

g is a one-to-one function as there are no two elements in the domain that map to the same image.

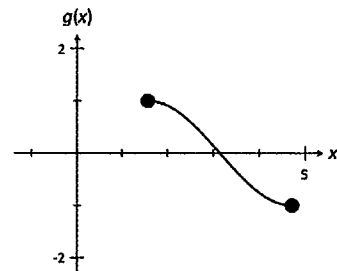
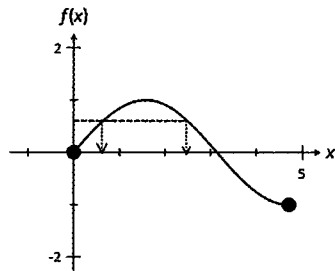

Notes:

- A function is a many-to-one function if it fails the horizontal line test.
- Clearly the graph of g passes the horizontal line test and hence g is a one-to-one function.
- As seen above, the graph of f fails the horizontal line test and hence f is a many-to-one function.

- (b) The graph of $f(x) = \cos(x)$ “passes the horizontal line test” for $[-\pi, 0]$ or $[0, \pi]$.
Hence, required domain is $[-\pi, 0]$ or $[0, \pi]$.

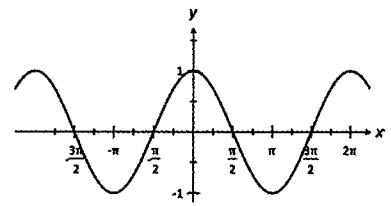

- (c) The graph of $f(x) = \tan(x)$ “passes the horizontal line test” for $\left(-\frac{\pi}{2}, \frac{\pi}{2}\right)$.

Hence, required domain is $\left(-\frac{\pi}{2}, \frac{\pi}{2}\right)$.

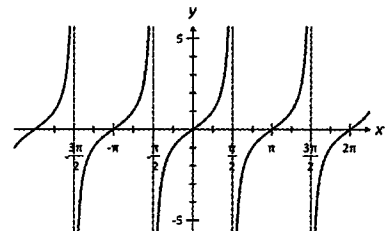

Notes:

- The domain that makes the circular functions $\sin(x)$, $\cos(x)$ and $\tan(x)$ one-to-one functions is called the principal domain.
- The principal domain for $\sin(x)$ is conventionally set as $\left[-\frac{\pi}{2}, \frac{\pi}{2}\right]$.
- The principal domain for $\cos(x)$ is $[0, \pi]$.
- The principal domain for $\tan(x)$ is $\left(-\frac{\pi}{2}, \frac{\pi}{2}\right)$.

Exercise 4.1

- Determine if each of the following functions are onto functions or otherwise.
 - $f(x) = -2x + 10$ with domain $\{x: x \geq 1, x \in \mathbb{R}\}$ and codomain \mathbb{R} .
 - $f(x) = e^x$ with domain \mathbb{R} and codomain \mathbb{R} .
 - $f(x) = x^2 - 10$ with domain \mathbb{R} and codomain \mathbb{R} .
 - $f(x) = x(x - 2)^2$ with domain \mathbb{R} and codomain \mathbb{R} .
- The graphs of the functions f are drawn in the accompanying diagrams. Determine with reasons if these functions are one-to-one or many-to-one functions.

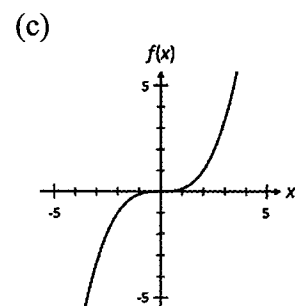
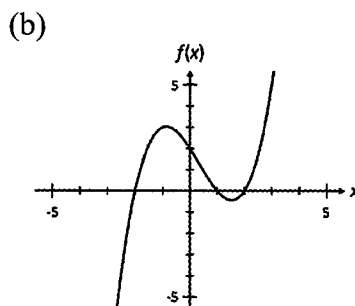
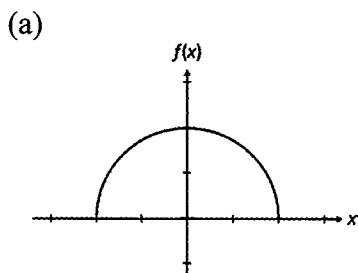

3. Determine analytically if each of the following functions are one-to-one or many-to-one.

(a) $f(x) = 3 - 2x$

(b) $f(x) = 2 + (x - 1)^2$

(c) $f(x) = (x - 1)^3$

(d) $f(x) = (x - 1)(x + 2)(x - 3)$

(e) $f(x) = \frac{1}{x}$

(f) $f(x) = \frac{1}{(x - 2)^2}$

(g) $f(x) = 5 - (x + 1)^2$ for $x \geq 0$

(h) $f(x) = (x - 2)^4$ for $x \geq 0$

(i) $f(x) = \sin(x)$ for $-\pi \leq x < \pi$

(j) $f(x) = \cos^2(x)$ for $0 \leq x \leq \pi$

4. Find the largest possible domain for each of the following functions to be one-to-one.

(a) $f(x) = (2x - 3)^2$

(b) $f(x) = 4 - 3(x + 2)^2$

(c) $f(x) = \frac{1}{(x + 1)^2} + 1$

(d) $f(x) = 1 - (x + 2)^3$

(e) $f(x) = \sqrt{(x - 2)^2 + 1}$

(f) $f(x) = \sqrt{(2x - 5)^2 + 4}$

(g) $f(x) = \sqrt{25 - (x + 2)^2}$

(h) $f(x) = 4 - \sqrt{16 - (x - 2)^2}$

(i) $f(x) = \sqrt{4 - x^2}$

(j) $f(x) = \sqrt{(x - 1)^2 - 1}$

5. Find the largest possible domain with the limits of the domain being numerically as close to 0 as is possible for each of the following functions to be one-to-one.

(a) $f(x) = \sin(2x)$

(b) $f(x) = \cos(x/2)$

(c) $f(x) = \tan(x + \pi/4)$

(d) $f(x) = \cos^2(x)$

(e) $f(x) = 2 \operatorname{cosec}(x/2)$

(f) $f(x) = 3 \sin(x) + 4 \cos(x)$

4.2 Composition of Functions

- In this section we will explore the procedure for combining two or more functions.

- Let h represent the composition of function f followed by function g .

- This is written symbolically as $h = g \circ f$ or $h = gf$.

- The image for x under h is written as

$$h(x) = g \circ f(x) \equiv g(f(x))$$

$$\text{or } h(x) = gf(x) \equiv g(f(x)).$$

- The composition of two or more functions may or may not be a function. Hence we also need to determine the mathematical conditions for which the composition of two or more functions is a function.

• **Case 1**

- The diagram below shows schematically the mappings for two functions f and g .

- The domain for f is $\{1, 2, 3\}$ and the range for f is $\{11, 12, 13\}$.
- The domain for g is $\{11, 12, 13\}$ and the range for g is $\{16, 17, 18\}$.

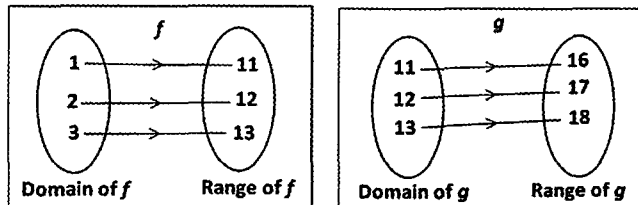

- Consider $h = g \circ f$.
- From the schematic mappings:

$$h(1) = g(f(1)) = g(11) = 16$$

$$h(2) = g(f(2)) = g(12) = 17$$

$$h(3) = g(f(3)) = g(13) = 18$$
- In this instance, h is a function as each element in its domain has a unique image.
- The domain of h is $\{1, 2, 3\}$ and the corresponding range is $\{16, 17, 18\}$.

• **Case 2**

- The diagram below shows schematically the mappings for two functions f and g .

- The domain for f is $\{1, 2, 3\}$ and the range for f is $\{11, 12, 13\}$.
- The domain for g is $\{11, 12, 13, 14\}$ and the range for g is $\{16, 17, 18, 19\}$.

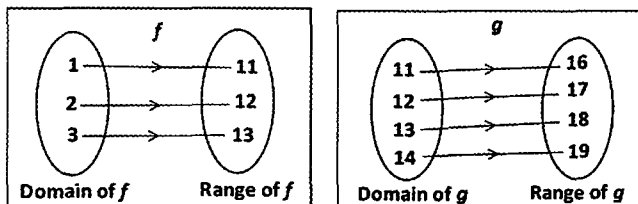

- Consider $h = g \circ f$.
- Clearly:

$$h(1) = g(f(1)) = g(11) = 16$$

$$h(2) = g(f(2)) = g(12) = 17$$

$$h(3) = g(f(3)) = g(13) = 18$$
- In this instance, h is a function as each element in its domain has a unique image.
- The domain for h is $\{1, 2, 3\}$ and the its range is $\{16, 17, 18\}$.

- **Case 3**

- The diagram below shows schematically the mappings for two functions f and g .

- The domain for f is $\{1, 2, 3\}$ and the range for f is $\{11, 12, 13\}$.
- The domain for g is $\{11, 12, 14\}$ and the range for g is $\{16, 17, 19\}$.

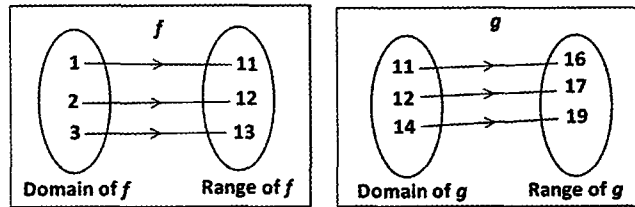

- Consider $h = gf$.
 - Clearly:
 - $h(1) = g(f(1)) = g(11) = 16$
 - $h(2) = g(f(2)) = g(12) = 17$
 - $h(3) = g(f(3)) = g(13)$ does not exist
 - In this instance, h is not a function as there is an element in its domain that does not have an image.
-
- In Case 1, the composition $g(f(x))$ is a function.
 - Note that the range of $f \equiv$ domain of $g = \{11, 12, 13\}$
 - In Case 2, the composition $g(f(x))$ is a function.
 - Note that the range of $f = \{11, 12, 13\}$ and the domain of $g = \{11, 12, 13, 14\}$.
 - That is, the range of $f \subset$ domain of g .
 - In Case 3, the composition $g(f(x))$ is a not function.
 - Note that the range of $f = \{11, 12, 13\}$ and the domain of $g = \{11, 12, 14\}$.
 - That is, the range of $f \not\subset$ domain of g .
-
- In general, the composition $g(f(x))$ is a function only if the range of $f \subseteq$ the domain of g .
 - That is, the range of the first function applied is a subset of the domain of the second function applied.
 - The domain of $g(f(x))$ is not necessarily the domain of f . See Example 4.8.

Example 4.6

Given that $f(x) = x + 4$ and $g(x) = \sqrt{x}$, determine with reasons if each of the following compositions are functions. (a) fg (b) gf (c) f^2 (d) g^2 .

Solution:

(a) Range for g is $\{x: x \geq 0, x \in \mathbb{R}\}$ or \mathbb{R}_0^+ . Domain for f is \mathbb{R} .
Hence, range of $g \subset$ domain of f . $\Rightarrow fg$ is a function.

(b) Range for f is \mathbb{R} . Domain for g is \mathbb{R}_0^+ .
Hence, range of $g \not\subset$ domain of f . $\Rightarrow gf$ is not a function.

(c) Range for f is \mathbb{R} . Domain for f is \mathbb{R} .
Hence, range of $f \equiv$ domain of f . $\Rightarrow f^2$ is a function.

(d) Range for g is \mathbb{R}_0^+ . Domain for g is \mathbb{R}_0^+ .
Hence, range of $g \equiv$ domain of g . $\Rightarrow g^2$ is a function.

Example 4.7

Let $f(x) = 2x + 3$, and $g(x) = \frac{1}{x+2}$. Find the rule for: (a) fg (b) gf (c) f^2 (d) g^2 .

Solution:

$$\begin{aligned} \text{(a)} \quad fg(x) &= f(g(x)) \\ &= f\left(\frac{1}{x+2}\right) = \frac{2}{x+2} + 3. \end{aligned}$$

$$\begin{aligned} \text{(b)} \quad gf(x) &= g(f(x)) \\ &= g(2x+3) = \frac{1}{(2x+3)+2} = \frac{1}{2x+5} \end{aligned}$$

$$\begin{aligned} \text{(c)} \quad f^2(x) &= f(f(x)) \\ &= f(2x+3) = 2(2x+3) + 3 = 4x+9 \end{aligned}$$

$$\begin{aligned} \text{(d)} \quad g^2(x) &= g(g(x)) \\ &= g\left(\frac{1}{x+2}\right) = \frac{1}{\left(\frac{1}{x+2}\right)+2} = \frac{x+2}{2x+5} \end{aligned}$$

Example 4.9

Let $f(x) = (x - 1)^2$ and $g(x) = \sqrt{x} + 1$.

- (a) Find the rule for fg given that fg is a function.
 (b) Determine the domain and range for fg .

Solution:

$$\begin{aligned} \text{(a)} \quad fg(x) &= f(g(x)) \\ &= f(\sqrt{x} + 1) \\ &= (\sqrt{x} + 1 - 1)^2 \\ &= (\sqrt{x})^2 = x \end{aligned}$$

- (b) Natural domain for g is \mathbb{R}_0^+ . Range for g is $[1, \infty)$. Domain for f is \mathbb{R} .

Hence, range for $g \subset$ domain for f .

It is therefore not necessary to restrict the domain of g .

Hence, domain for $fg =$ natural domain for g

$$= \mathbb{R}_0^+.$$

The corresponding range of $fg = \mathbb{R}_0^+$.

Notes:

- By just observing the rule for $fg(x) = x$ it would “appear” that the domain for fg would be \mathbb{R} .
- This would be incorrect as $fg(x) \equiv f(\sqrt{x} + 1)$ which requires $x \geq 0$.
- As mentioned in the notes accompanying Example 4.8, caution must be used if you choose to determine the domain or range of a composite function by observing the structure of the composite rule.

Example 4.10

Let $f(x) = \ln(x)$, $x > 1$ and $g(x) = x - 1$.

- (a) Find the largest possible domain for g so that fg is a function.
 (b) Using this domain for g , state the rule, domain and range for fg .

Solution:

Natural domain for $g = \mathbb{R}$. Range for $g = \mathbb{R}$.

Given domain for $f = (1, \infty)$. Range for $f = (0, \infty)$.

- (a) For the range of g to be within the domain of f , the range of g needs to be restricted to $(1, \infty)$.

$$\text{That is, } 1 < x - 1 < \infty \Rightarrow 2 < x < \infty.$$

Hence, the largest possible domain for g is $(2, \infty)$.

- (b) $fg(x) = f(g(x)) = f(x - 1) = \ln(x - 1)$.

Domain of $fg =$ restricted domain for $g = (2, \infty)$.

Corresponding range of $fg = \mathbb{R}^+$.

Example 4.11

Given that $fg(x) = \frac{2}{1-x}$ and $f(x) = \frac{x}{x+1}$, find the rule for g .

Solution:

$$\begin{aligned} \text{Using the rule for } f: \quad fg(x) &= f(g(x)) \\ &= \frac{g(x)}{g(x)+1} \end{aligned}$$

$$\text{But} \quad fg(x) = \frac{2}{1-x}$$

$$\begin{aligned} \text{Hence,} \quad \frac{g(x)}{g(x)+1} &= \frac{2}{1-x} \\ g(x) - xg(x) &= 2g(x) + 2 \\ g(x) + xg(x) &= -2 \\ (1+x)g(x) &= -2 \\ g(x) &= \frac{-2}{1+x}. \end{aligned}$$

Example 4.12

Given that $fg(x) = 1 + x^2$ and $g(x) = x - 1$, find the rule for f .

Solution:

$$\begin{aligned} \text{Using the rule for } g: \quad fg(x) &= f(g(x)) \\ &= f(x-1) \end{aligned}$$

$$\text{But} \quad fg(x) = 1 + x^2$$

$$\text{Hence,} \quad f(x-1) = 1 + x^2 \quad [1]$$

$$\text{Let } u = x - 1 \Rightarrow x = u + 1$$

Substitute $u = x - 1$ and $x = u + 1$ into [1],

$$\begin{aligned} f(u) &= 1 + (u+1)^2 \\ &= u^2 + 2u + 2 \end{aligned}$$

Hence, the rule for f is $f(x) = x^2 + 2x + 2$.

Exercise 4.2

- Given that $f(x) = x - 4$ and $g(x) = \sqrt{x-1}$, determine with reasons if each of the following compositions are functions. (a) fg (b) gf (c) f^2 (d) g^2 .
- Given that $f(x) = 2^x$ and $g(x) = \sqrt{x+1}$, determine with reasons if each of the following compositions are functions. (a) fg (b) gf (c) f^2 (d) g^2 .

3. Given that $f(x) = 1 - 2x$ and $g(x) = \frac{1}{x+2}$, determine with reasons if each of the following compositions are functions. (a) fg (b) gf (c) f^2 (d) g^2 .
4. Given that $f(x) = 3^x$ and $g(x) = \frac{1}{x-9}$, determine with reasons if each of the following compositions are functions. (a) fg (b) gf (c) f^2 (d) g^2 .
5. Let $f(x) = x - 3$, and $g(x) = x^2 + 3$. Find the rule for: (a) fg (b) gf (c) f^2 (d) g^2 .
6. Let $f(x) = \frac{1}{x+1}$, and $g(x) = x^2 - 1$. Find the rule for: (a) fg (b) gf (c) f^2 (d) g^2 .
7. Let $f(x) = e^x$, and $g(x) = 1 + 2x$. Find the rule for: (a) fg (b) gf (c) f^2 (d) g^2 .
8. Let $f(x) = \frac{1}{1-x}$, and $g(x) = \frac{x}{1+x}$. Find the rule for: (a) fg (b) gf (c) f^2 (d) g^2 .
9. Let $f(x) = 5 - x$ and $g(x) = 1/x$.
 (a) State the natural domain and corresponding natural range for f and g .
 (b) Find the largest possible domain for f so that gf is a function.
 (c) Using this domain for f , state the composition rule, domain and range for gf .
10. Let $f(x) = x^2 - 5$ and $g(x) = \sqrt{1+x}$.
 (a) State the natural domain and corresponding natural range for f and g .
 (b) Find the largest possible domain for g so that fg is a function.
 (c) Using this domain for g , state the composition rule, domain and range for fg .
11. Given that $f(x) = (x - 1)^2$ where $x > 2$ and $g(x) = 1 + \sqrt{x}$, find the largest possible domain for g so that fg is a function. Using the restricted domain, state the rule, domain and range for the composite function fg .
12. Given that $f(x) = x^2 + 2$ and $g(x) = 1 + \sqrt{x-2}$ where $x \geq 3$, find the largest possible domain for f so that gf is a function. Using the restricted domain, state the rule, domain and range for the composite function gf .
13. Given that $f(x) = \ln(x)$, $g(x) = x + 1$ and $h(x) = \sin(x)$; determine the rule for each of the following and state with justification whether the composition is a function. If the composition is a function, state the domain and range of the composite function.
 (a) fgh (b) ghf
14. Given that $f(x) = 5^x$; $g(x) = x^2$, and $h(x) = \sqrt{25-x}$; determine the rule for each of the following and state with justification whether the composition is a function. If the composition is a function, state the domain and range of the composite function.
 (a) fgh (b) ghf

15. Given that $fg(x) = x + 3$ and $f(x) = x - 2$, find the rule for g .
16. Given that $fg(x) = x - 2$ and $f(x) = 1/x$, find the rule for g .
17. Given that $fg(x) = \frac{x}{x+1}$ and $f(x) = 2x + 1$, find the rule for g .
18. Given that $fg(x) = x + 4$ and $g(x) = 1 - x$, find the rule for f .
19. Given that $fg(x) = 2x - 1$ and $g(x) = x + 1$, find the rule for f .
20. Given that $gf(x) = x^2 + 1$ and $f(x) = x + 3$, find the rule for g .
21. Given that $gf(x) = \frac{x}{x+1}$ and $f(x) = \frac{1}{1-2x}$, find the rule for g .

4.3 Inverse of a Function

- The *inverse of a function* is a relation that maps the image back to the original object.
 - The inverse of a function f may or may not be a function.
 - If the inverse of a function f is also a function, it called an *inverse function*.
 - The inverse function is denoted f^{-1} .
- Where the domain and codomain of a function f are specified, then the inverse function f^{-1} exists only if f is a *one-to-one and onto* function.
 - If $f: X \rightarrow Y$, such that $f(x) = y$,
 $f^{-1}: Y \rightarrow X$, and $f^{-1}(y) = x$.
- If the domain of f is given or the natural domain is assumed with no mention of the codomain, then f^{-1} exists only if f is a *one-to-one* function.
 - If $fg(x) = gf(x) = x$, then $g = f^{-1}$.
 - The domain of f^{-1} = the range for f
 The range of f^{-1} = the natural (or restricted) domain of f .
- Graphically, f^{-1} exists only if the graph of f passes the horizontal line test.

Example 4.13

Prove that if f is a many-to-one function, then the inverse of f cannot be a function.

Solution:

As f is a many-to-one function $\exists a, b$ in the domain of f such that $a \neq b$ and f maps both a and b to a common image k .

Hence, the inverse of f will map the image k to a as well as b .

This makes the inverse of f a one-to-many mapping which is not a function.

Example 4.14

The graph of a function f is given below.

- (a) Verify that the inverse of f is not a function.
- (b) Find the largest possible domain for f such that the inverse of f is a function.
- (c) State the domain and range for the inverse of f corresponding to the restricted domain of f in part (b).

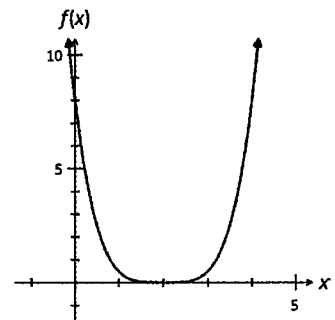

Solution:

- (a) f is not a one-to-one function as it fails the horizontal line test. Hence, the inverse of f is not a function.
- (b) From the graph of f , f is a one-to-one function for $x \geq 2$ (or $x \leq 2$). Hence, the largest possible domain over which f is a one-to-one function is $[2, \infty)$ or $(-\infty, 2]$.
- (c) The domain for the inverse of $f = \text{range for } f = [0, \infty)$
The range for the inverse of $f = \text{restricted domain for } f = [2, \infty)$ or $(-\infty, 2]$.

Example 14.15

Determine with justification, if the inverse of $f: \mathbb{R} \rightarrow \mathbb{R}$, $f(x) = 4x + 1$ is a function. Find the rule for the inverse function if it exists.

Solution:

Clearly, f is a *one-to-one* function.

The range of $f = \text{codomain of } f = \mathbb{R}$. Hence, f is also an *onto* function.

Hence, the inverse of f is a function.

To find the inverse rule, let $y = 4x + 1$

Express x in terms of y $x = \frac{y-1}{4}$

Since $f(x) = y$, then $f^{-1}(y) = x$

Hence $f^{-1}(y) = \frac{y-1}{4}$

That is, the rule for the inverse is $f^{-1}(x) = \frac{x-1}{4}$

Note:

- In writing the rule, the “letters” x and y are dummy variables. It is immaterial which letter is used. What is important is the relationship that is expressed. By convention, when stating mapping rules, the letter x is used.

Example 14.16

Determine with justification, if the inverse of each of the following functions are functions. Find the rule for the inverse function where it exists.

(a) $f(x) = (x-1)^2$ (b) $f(x) = \ln(x)$ (d) $f(x) = \frac{1}{1+x}$

Solution:

- (a) The natural domain for f is \mathbb{R} .

$$f(2) = 1 \text{ and } f(0) = 1$$

Hence, f is not a one-to-one function within its natural domain.

Therefore, the inverse of f (within the natural domain of f) is not a function.

- (b) f is a one-to-one function within its natural domain.

Hence, the inverse of f is a function.

For the inverse rule, let $y = \ln(x)$

Express x in terms of y $x = e^y$

Since $f(x) = y$, $f^{-1}(y) = x = e^y$

Hence, the inverse rule is $f^{-1}(x) = e^x$

- (c) f is a one-to-one function within its natural domain.

Hence, the inverse of f is a function.

For the inverse rule, let $y = \frac{1}{1+x}$

Express x in terms of y $1+x = \frac{1}{y}$

$$x = \frac{1}{y} - 1 = \frac{1-y}{y}$$

Hence, the inverse rule is $f^{-1}(x) = \frac{1-x}{x}$

Example 14.17

The function f is defined by the rule $f(x) = x^2 + 1$.

- (a) Verify that within the natural domain of f , the inverse of f is not a function.
- (b) Find the largest possible domain for f so that the inverse of f is a function.
- (c) For the domain of f defined in (b), give the rule for f^{-1} and its corresponding domain and range.

Solution:

(a) $f(2) = 5$ and $f(-2) = 5$.

Hence, f is not a one-to-one function within its natural domain.
Therefore the inverse of f is not a function.

(b) The rule $f(x) = x^2 + 1$ is symmetrical about $x = 0$.

Hence, for $x \geq 0$ (or $x \leq 0$), f becomes a one-to-one function.
Therefore, the largest possible domain for f so that its inverse is a function is $[0, \infty)$ or $(-\infty, 0]$.

(c) For the inverse rule, let $y = x^2 + 1$
Express x in terms of y , $x = \pm \sqrt{y-1}$
Since $f(x) = y$, $f^{-1}(y) = x$
which gives $f^{-1}(y) = \pm \sqrt{y-1}$

For f with domain $[0, \infty)$, the rule for the inverse of f is $f^{-1}(x) = \sqrt{x-1}$.
The domain of f^{-1} = range of f = $[1, \infty)$.
The range of f^{-1} = domain of f = $[0, \infty)$.

For f with domain $(-\infty, 0]$, the rule for the inverse of f is $f^{-1}(x) = -\sqrt{x-1}$.
The domain of f^{-1} = range of f = $[1, \infty)$.
The range of f^{-1} = domain of f = $(-\infty, 0]$.

Note:

- In this example, the inverse of f is not a function when the natural domain of f is used. However, if we restrict the domain of f , the inverse of f becomes a function.
- The rule $f^{-1}(y) = \pm \sqrt{y-1}$ clearly is not a function rule.
There is therefore a need to determine which rule matches the restricted domain used.

Exercise 4.3

1. The graph of f is given below.

- (i) In each case, determine if the inverse of f is a function.
- (ii) If the inverse of f is not a function, find the largest possible domain for f so that the inverse of f is a function.
- (iii) State the domain and range of the inverse function.

(a)

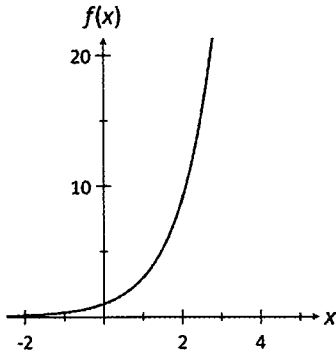

(b)

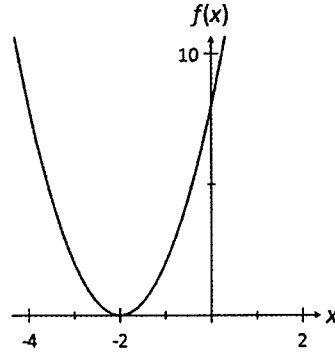

(c)

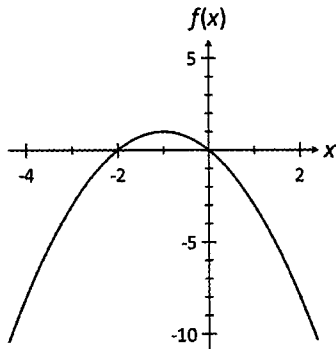

(d)

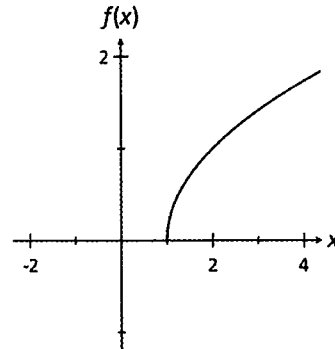

2. Determine (with justification) if the inverses of the following functions are functions.

(a) $f: \mathbb{R} \rightarrow \mathbb{R}, f(x) = 1 - 4x$

(b) $f: \mathbb{R} \rightarrow \mathbb{R}, f(x) = (x - 2)^2$

(c) $f(x) = (1 + 2x)^2$

(d) $f(x) = \sqrt{x + 3}$

(e) $f(x) = \frac{2}{x}$

(f) $f(x) = \frac{1}{1 + x}$

(g) $f(x) = e^{1+x}$

(h) $f(x) = (3 - 2x)^2, x \geq 1.5$

(i) $f(x) = \sin(x), -\pi \leq x \leq \pi$

(j) $f(x) = \tan(x), 0 \leq x \leq 2\pi$

3. For each of the following functions, find the rule for inverse relation.

(a) $f(x) = 3 + 2x$

(b) $f(x) = -5x - 4$

(c) $f(x) = (x - 4)^2$

(d) $f(x) = 1 - (x - 2)^2$

(e) $f(x) = (2x + 5)^2$

(f) $f(x) = x^3$

(g) $f(x) = e^{1+2x}$

(h) $f(x) = \ln(1 + 2x)$

(i) $f(x) = \frac{1}{1-x}$

(j) $f(x) = \frac{1-x}{x+1}$

(k) $f(x) = \sqrt{x+1}$

(l) $f(x) = \frac{1}{\sqrt{x-1}}$

4. For each of the following functions f :
- verify that within the natural domain of f , the inverse of f is not a function.
 - Find the largest possible domain for f so that the inverse of f is a function.
 - Using this domain for f , state the rule for the inverse of f and its corresponding domain and range.

(a) $f(x) = (x + 4)^2$	(b) $f(x) = 1 + (x - 2)^2$	(c) $x^2 - 1$
(d) $f(x) = (x + 1)^2 + 1$	(e) $f(x) = \frac{1}{1 + x^2}$	(f) $\frac{1}{(x - 1)^2}$
(g) $f(x) = \sin(x)$	(h) $f(x) = \cos(2x)$	(i) $f(x) = \tan\left(\frac{x}{2}\right)$

5. Given that $f(x) = \sqrt{1 - x}$ and $g(x) = e^x$:
- find the rule for composite function fg and state its natural domain and range
 - find the rule for composite function gf and state its natural domain and range
 - determine the inverse functions $(fg)^{-1}$ and $(gf)^{-1}$ where they exist.

6. Let $f(x) = 2x + 1$ and $g(x) = \frac{1}{4 - x}$.

- Determine the rules for the inverse functions f^{-1} , g^{-1} and $(gf)^{-1}$.
- Verify that $(gf)^{-1} = f^{-1}g^{-1}$.

7. Let $f(x) = \sqrt{x + 1}$ and $g(x) = \frac{1}{x + 1}$.

- Determine the rules for the inverse functions f^{-1} , g^{-1} and $(fg)^{-1}$.
- Verify that $(fg)^{-1} = g^{-1}f^{-1}$.

8. Let $f(x) = x^2$ and $g(x) = \sqrt{x}$. Determine the domain of f and g so that:
- f is the inverse of g .
 - g is the inverse of f .

9. Let $f(x) = (1 - x)^2$ and $g(x) = 1 - \sqrt{x}$. Determine the domain of f and g so that:
- f is the inverse of g .
 - g is the inverse of f .

10. Let $f(x) = \frac{1}{\sqrt{x + 1}}$ and $g(x) = \frac{1}{x^2} - 1$.

Determine the domain of f and g so that f is the inverse of g .

05 Sketching Techniques

5.1 Graphs of Inverse Functions

- In the previous chapter, it was noted that if $f(x) = y$, then the inverse function f^{-1} will map y back to x .
 - That is, a point (h, k) on the curve $y = f(x)$ corresponds to the point (k, h) on the curve $y = f^{-1}(x)$.
 - Hence, the graph of $y = f^{-1}(x)$ may be obtained by reflecting the graph of $y = f(x)$ about the line $y = x$.
 - The graphs of $y = f(x)$ and $y = f^{-1}(x)$ should they intersect, will intersect along the line $y = x$.
- The table below summarises the distinguishing features between the graphs of $y = f(x)$ and $y = f^{-1}(x)$.

$y = f(x)$	$y = f^{-1}(x)$
Root at $x = a$	Vertical intercept at $y = a$
Vertical intercept at $y = a$	Root at $x = a$
Horizontal asymptote: $y = a$	Vertical Asymptote: $x = a$
Vertical Asymptote: $x = a$	Horizontal asymptote: $y = a$

Example 5.1

Given the sketch of $y = f(x)$, sketch the graph of $y = f^{-1}(x)$.

Solution:

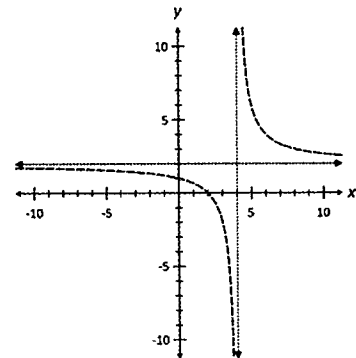
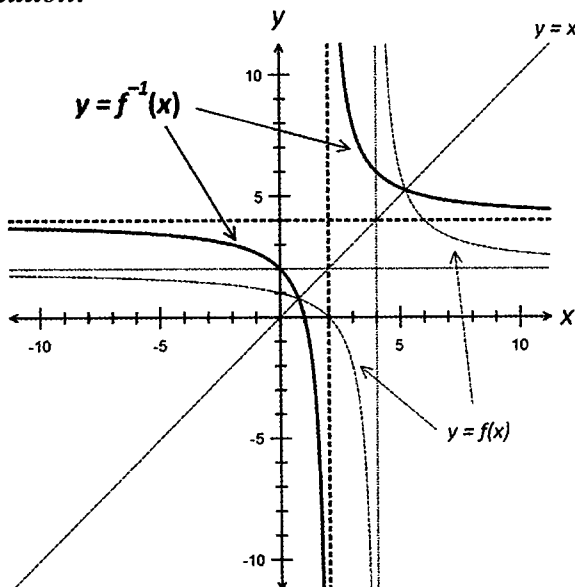

$y = f(x)$	$y = f^{-1}(x)$
Root at $x = 2$	Vertical intercept at $y = 2$
Vertical intercept at $y = 1$	Root at $x = 1$
Horizontal asymptote $y = 2$	Vertical asymptote $x = 2$
Vertical asymptote $x = 4$	Horizontal asymptote $y = 4$

5.2 Graphs of Reciprocals $y = \frac{1}{f(x)}$

- The sketch of the curve $y = \frac{1}{f(x)}$ may be obtained from the graph of $y = f(x)$ by “manipulating” the graph of $y = f(x)$.
 - The point (h, k) for $k \neq 0$ on the graph of $y = f(x)$ corresponds to the point $(h, \frac{1}{k})$ on the graph of $y = \frac{1}{f(x)}$.
- The graphs of $y = f(x)$ and $y = \frac{1}{f(x)}$ should they intersect will intersect on the lines $y = \pm 1$.
- The table below summarises the distinguishing features between the graphs of $y = f(x)$ and $y = \frac{1}{f(x)}$.

$y = f(x)$	$y = \frac{1}{f(x)}$
Root at $x = a$	Vertical Asymptote at $x = a$
Vertical intercept $(0, a)$ where $a \neq 0$	Vertical intercept $(0, \frac{1}{a}), a \neq 0$
Vertical Asymptote: $x = b$	Root at $x = b$
Horizontal asymptote: $y = a, a \neq 0$	Horizontal asymptote: $y = \frac{1}{a}$
Local Minimum at (h, k) where $k \neq 0$	Local Maximum at $(h, \frac{1}{k})$ where $k \neq 0$
Local Maximum at (h, k) where $k \neq 0$	Local Minimum at $(h, \frac{1}{k})$ where $k \neq 0$

Example 5.2

Given the sketch of $y = f(x)$, sketch the graph of $y = \frac{1}{f(x)}$.

Solution:

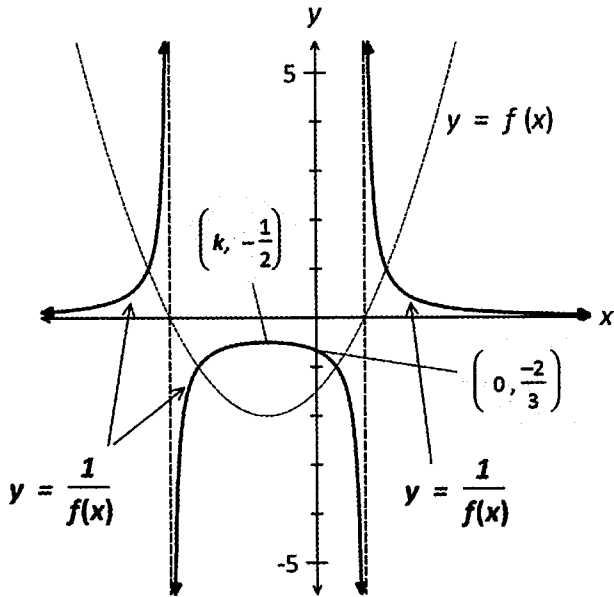
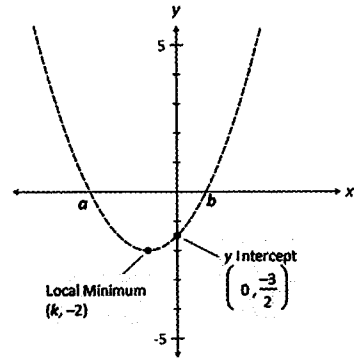

$y = f(x)$	$y = \frac{1}{f(x)}$
Roots at $x = a$, $x = b$	Vertical asymptotes $x = a, x = b$
Vertical Intercept at $y = -\frac{3}{2}$	Vertical Intercept at $y = -\frac{2}{3}$
Min point at $(k, -2)$	Max point at $(k, -\frac{1}{2})$

Exercise 5.1

1. For each of the following graphs sketch on the same set of axes the graph of $y = f^{-1}(x)$.

(a)

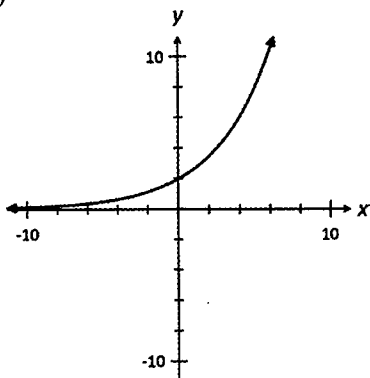

(b)

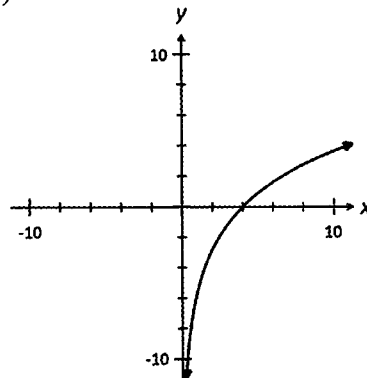

(c)

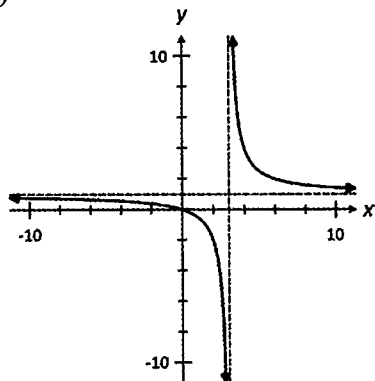

(d)

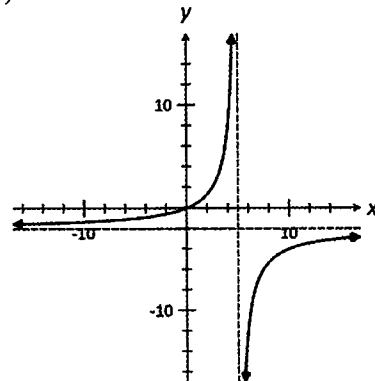

2. For each of the following graphs, sketch on the same set of axes, the graph of $y = f^{-1}(x)$.

(a)

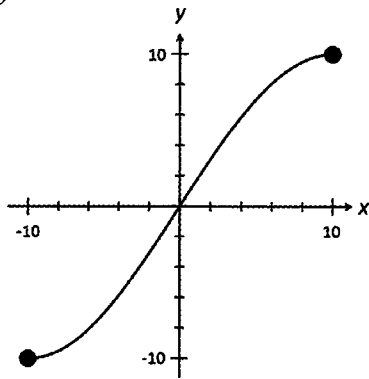

(b)

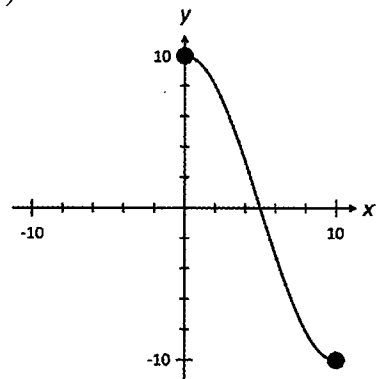

(c)

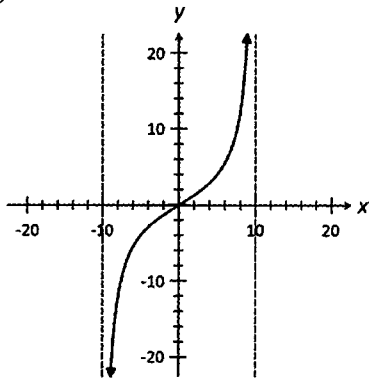

(d)

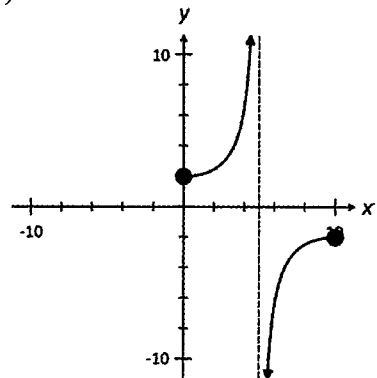

3. For each of the following graphs, sketch on the same set of axes, the graph of $y = 1/f(x)$.

(a)

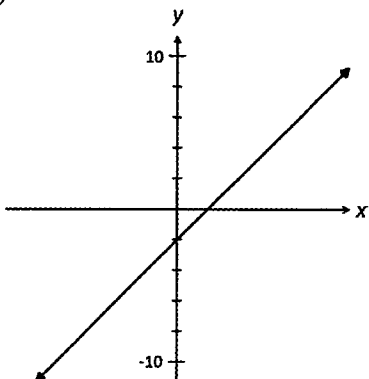

(b)

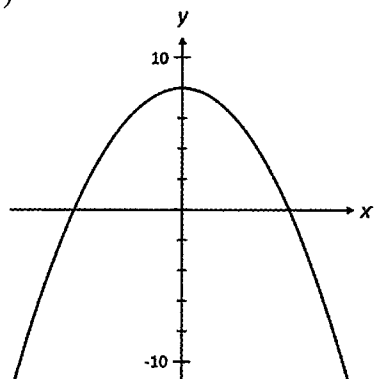

(c)

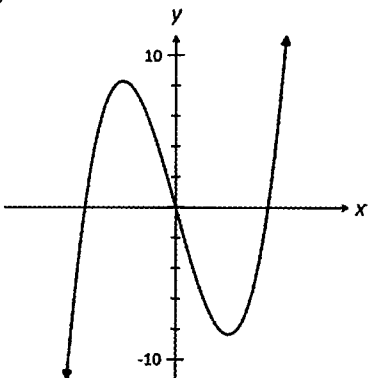

(d)

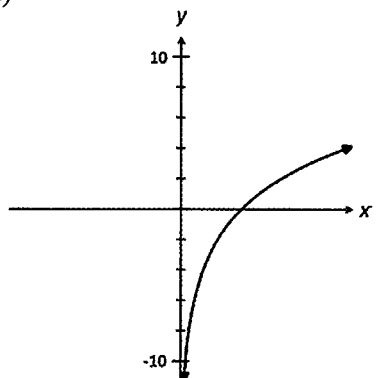

4. For each of the following graphs, sketch on the same set of axes, the graph of $y = \frac{1}{f(x)}$.

(a)

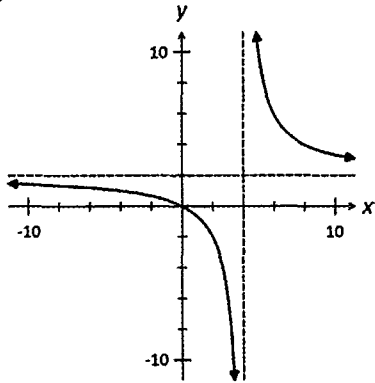

(b)

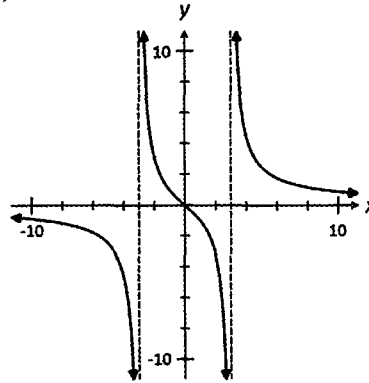

(c)

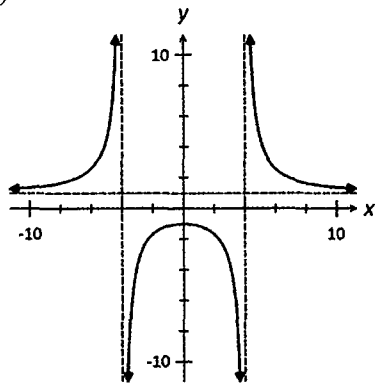

(d)

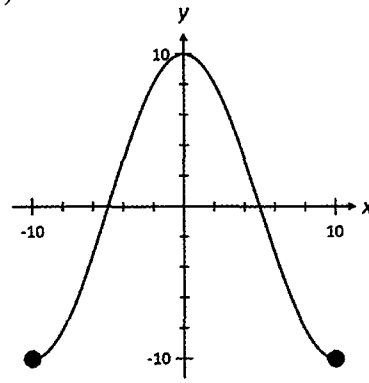

5. Without using a CAS/Graphic calculator, sketch the graph of $y = f(x)$.

On the same set of axes, sketch the graph of $y = f^{-1}(x)$.

(a) $y = x + 3$

(b) $x + y = 5$

(c) $y = \sqrt{x-1}$

(d) $y = 2 - \sqrt{x+1}$

(e) $y = 2^x - 4$

(f) $y = 4 - 10^{-x}$

(g) $y = \frac{1}{x+4}$

(h) $y = 5 - \frac{1}{2x-10}$

(i) $y = 5 \sin\left(\frac{\pi x}{5}\right)$ for $-\frac{5}{2} \leq x \leq \frac{5}{2}$

(j) $y = 5 \cos\left(\frac{\pi x}{5}\right)$ for $0 \leq x \leq \frac{5}{2}$

6. Without using a CAS/Graphic calculator, sketch the graph of $y = f(x)$.

On the same set of axes, sketch the graph of $y = 1/f(x)$.

(a) $y = 4 - x$

(b) $2x + 5y = 10$

(c) $y = \sqrt{2-x}$

(d) $y = 2 + 2^{-x}$

(e) $y = \ln(4-x)$

(f) $y = (x-2)(x+4)$

(g) $y = x(x-2)(x+2)$

(h) $y = \frac{x+3}{x-3}$

(i) $y = 4 \sin\left(\frac{\pi x}{4}\right)$ for $-8 \leq x \leq 8$

(j) $y = 3 \cos\left(\frac{\pi x}{3}\right)$ for $-6 \leq x \leq 6$

5.3 Graphs of Absolute Value Functions $y = |f(x)|$

- The absolute value of a real number is the “magnitude” of the number.
 - $|5| = 5$ $|-5| = 5$
 - That is, for $x \in \mathbb{R}$:

$$|x| = \begin{cases} -x & \text{if } x < 0 \\ x & \text{if } x \geq 0 \end{cases}$$

- If $y = |f(x)|$, then as a piecewise defined function:

$$y = \begin{cases} -f(x) & \text{over the interval for which } f(x) < 0 \\ f(x) & \text{over the interval for which } f(x) \geq 0 \end{cases}$$

- The graph of $y = |f(x)|$ may be obtained from the graph of $y = f(x)$ by *reflecting* about the x -axis any part of $y = f(x)$ that is *below* the x -axis.

Example 5.3

Show that the inverse of $f(x) = |x + 2|$ is not a function.

Solution:

$$f(0) = f(-4) = 0$$

Hence, $f(x)$ is not a one-to-one function. Therefore, its inverse is not a function.

Example 5.4

Rewrite the following functions as piecewise defined functions.

(a) $f(x) = 2x - 3$ (b) $f(x) = (x - 2)(x + 3)$

Solution:

$$(a) \quad f(x) < 0 \Rightarrow 2x - 3 < 0 \\ x < \frac{3}{2}$$

$$\text{Hence, } f(x) = \begin{cases} -(2x - 3) & x < \frac{3}{2} \\ 2x - 3 & x \geq \frac{3}{2} \end{cases}$$

$$(b) \quad f(x) < 0 \Rightarrow (x - 2)(x + 3) < 0 \\ -3 < x < 2$$

$$\text{Hence, } f(x) = \begin{cases} -(x - 2)(x + 3) & -3 < x < 2 \\ (x - 2)(x + 3) & x \leq -3, x \geq 2 \end{cases}$$

Example 5.5

Given the sketch of $y = f(x)$, sketch the graph of $y = |f(x)|$.

Solution:

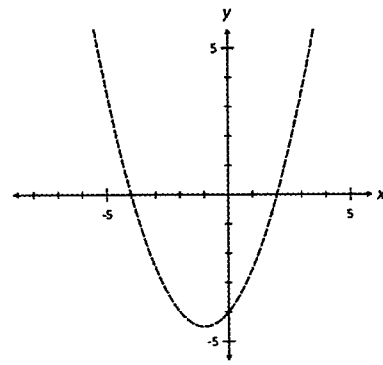
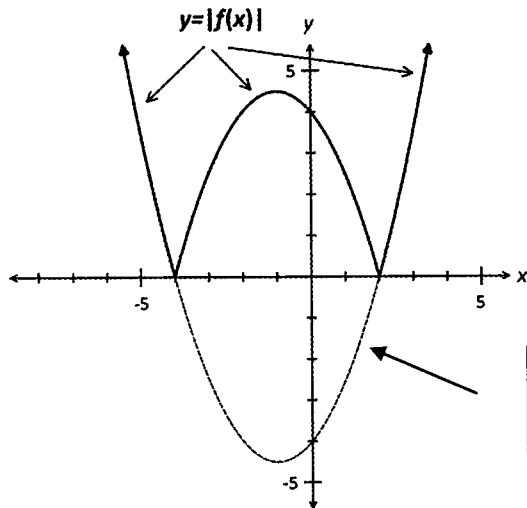

The graph of $y = f(x)$ is below the x -axis for $-4 < x < 2$. This part is reflected about the x -axis.

Note:

- In this example, $y = f(x)$ is a function. But as the graph of $y = |f(x)|$ fails the horizontal line test, the inverse of $y = |f(x)|$ is not a function.

Example 5.6

Given the sketch of $y = f(x)$, sketch the graph of :

(a) $y = |f(x)|$ (b) $y = \frac{1}{|f(x)|}$.

Solution:

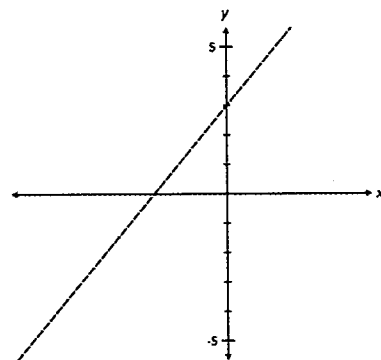
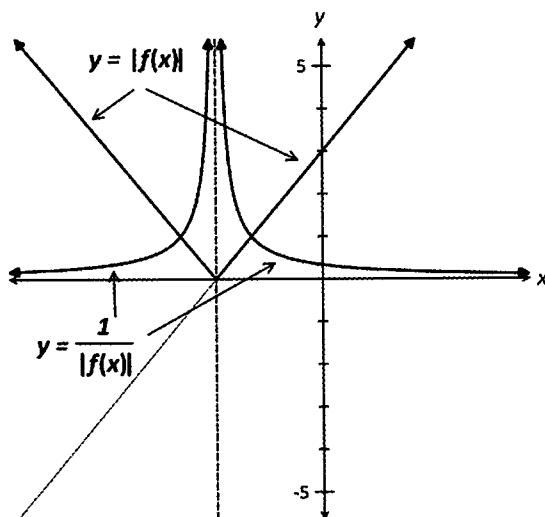

Example 5.7

Without the use of a calculator, sketch $y = |\ln(x + 3)|$.

Solution:

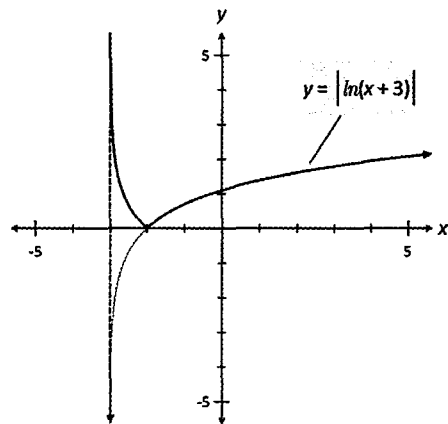

- First sketch $y = \ln(x + 3)$.
- Reflect about the x -axis any part of the curve that is below the x -axis.

5.4 Graphs of $y = f(|x|)$

- If $y = f(|x|)$, then as a piecewise defined function:

$$y = \begin{cases} f(-x) & x < 0 \\ f(x) & x \geq 0 \end{cases}$$

- The graph of $y = f(|x|)$ may be obtained from the graph of $y = f(x)$ as follows:
 - Parts of $y = f(x)$ to the right of the y -axis remain unchanged.
 - Parts of $y = f(x)$ to the left of the y -axis are completely removed and replaced by the reflection of the parts of $y = f(x)$ to the right of the y -axis.

Example 5.8

Let $f(x) = x^2 + 2x - 1$.

- (a) Determine the rule for $f(|x|)$. Hence, rewrite $f(|x|)$ as a piecewise defined function.
- (b) Hence, show that the inverse of $f(|x|)$ is not a function.

Solution:

- (a) Rule for $f(|x|) = |x|^2 + 2|x| - 1$.
As a piecewise defined function:

$$f(|x|) = \begin{cases} x^2 - 2x + 1 & x < 0 \\ x^2 + 2x - 1 & x \geq 0 \end{cases}$$

- (b) $f(|2|) = f(|-2|) = 7$.
Hence, $f(|x|)$ is not a one-to-one function. Therefore, its inverse is not a function.

Example 5.9

The sketch of $y = f(x)$ is given below.

Sketch the graphs of: (a) $y = |f(x)|$ (b) $y = f(|x|)$.

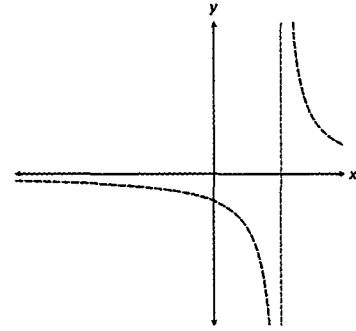

Solution:

(a)

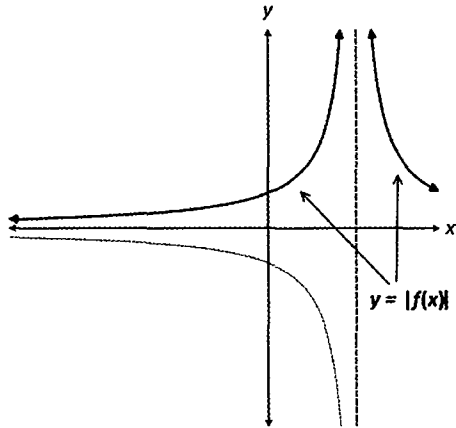

- Parts of $y = f(x)$ above the x -axis remain unchanged.
- Parts of $y = f(x)$ below the x -axis are reflected about the x -axis.

(b)

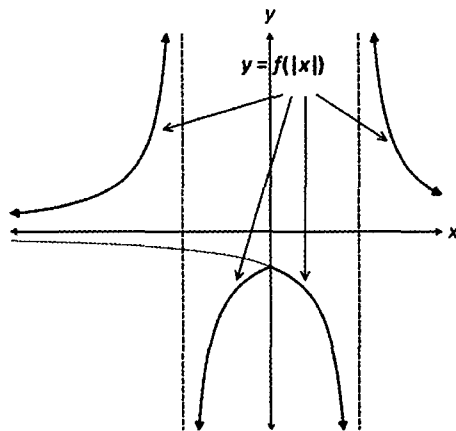

- Parts of $y = f(x)$ to the right of the y -axis remain unchanged.
- Parts of $y = f(x)$ to the left of the y -axis are completely removed and replaced by the reflection of the parts of $y = f(x)$ to the right of the y -axis.

Example 5.10

Without the use of a calculator, sketch $y = f(|x|)$ where $f(x) = (x + 1)(x - 2)$.

Solution:

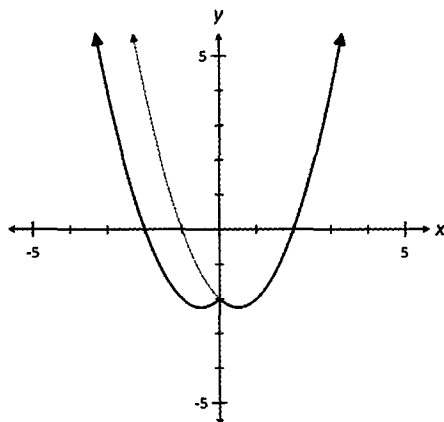

- First sketch $y = (x + 1)(x - 2)$.
- Remove the part of the curve that is to the left of the y -axis.
- Reflect remaining curve about the y -axis.

Exercise 5.2

1. The sketch of $y = f(x)$ is given below.

Sketch the graphs of (i) $y = |f(x)|$ (ii) $y = f(|x|)$.

(a)

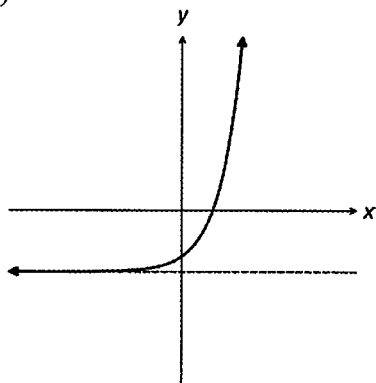

(b)

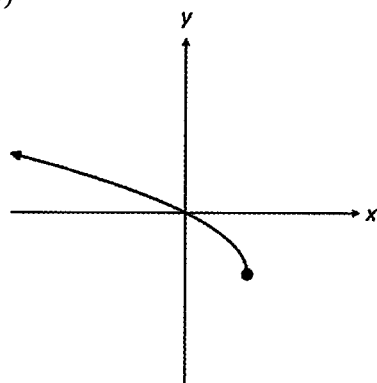

(c)

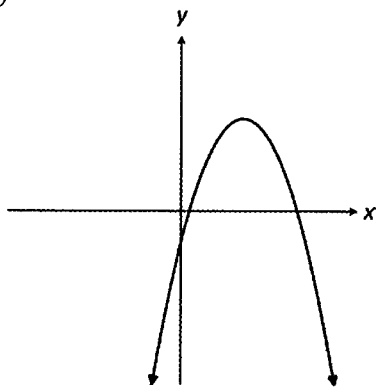

(d)

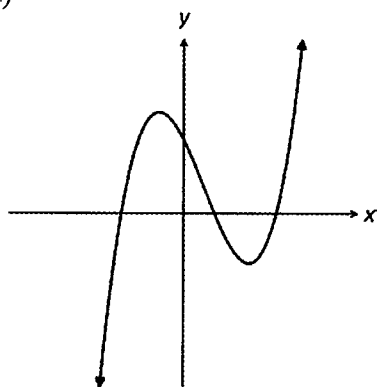

(e)

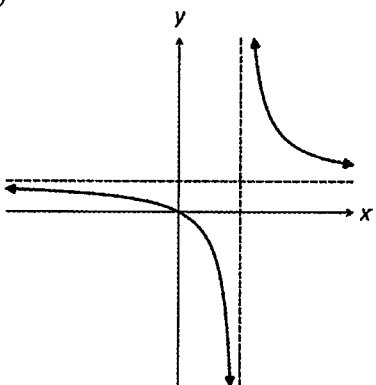

(f)

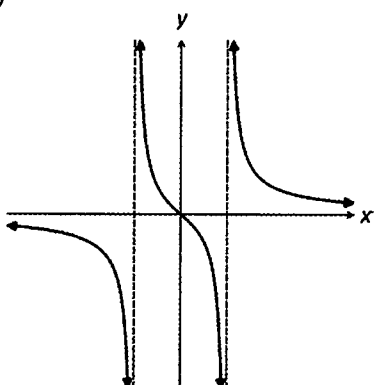

2. For each $y = f(x)$ as given below:

(i) write in piecewise form $y = |f(x)|$.

Hence, or otherwise, without the use of a calculator, sketch $y = |f(x)|$.

(ii) write in piecewise form $y = f(|x|)$.

Hence, or otherwise, without the use of a calculator, sketch $y = f(|x|)$.

- | | | | |
|----------------------------|-----------------------|---------------------------|-------------------------------|
| (a) $y = 2x + 5$ | (b) $y = 3 - x$ | (c) $y = (x + 3)(x - 3)$ | (d) $y = x^2 - 3x - 4$ |
| (e) $y = 2^x - 4$ | (f) $y = \ln(x + 2)$ | (g) $y = \sin(x)$ | (h) $y = \cos(x)$ |
| (i) $y = \sqrt{4 - x} - 2$ | (j) $y = e^{-2x} - 2$ | (k) $y = \frac{1}{x - 2}$ | (l) $y = \frac{1}{2 + x} + 2$ |

*3. Given the sketch of $y = f(x)$, sketch the graphs of (i) $|y| = f(x)$ (ii) $|y| = |f(x)|$.

(a)

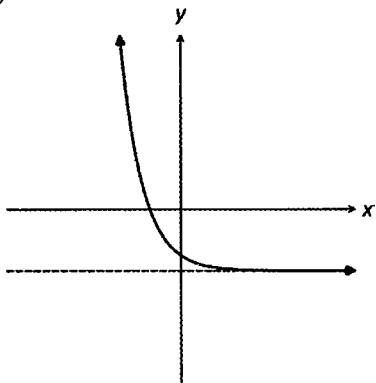

(b)

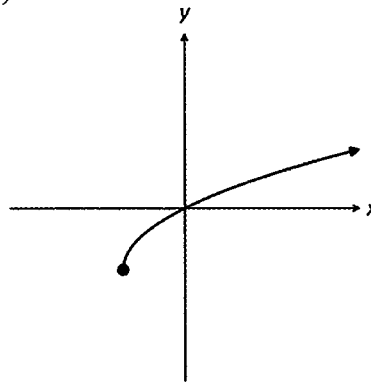

(c)

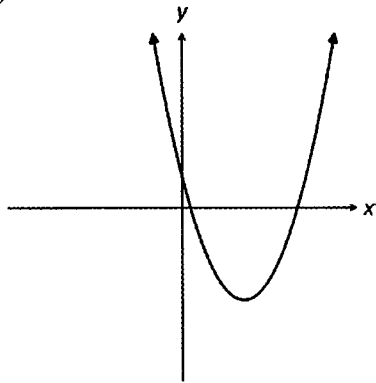

(d)

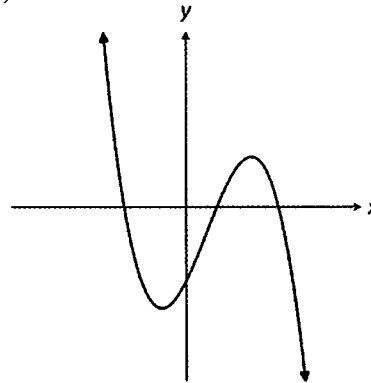

*4. Given the sketch of $y = f(x)$, sketch the graphs of (i) $|y| = f(|x|)$ (ii) $|y| = |f(|x|)|$.

(a)

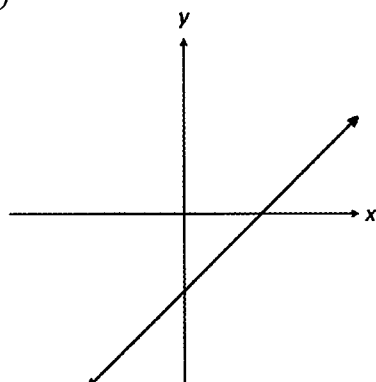

(b)

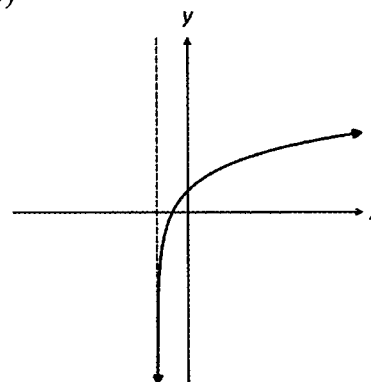

(c)

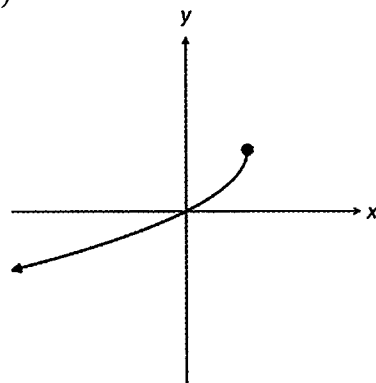

(d)

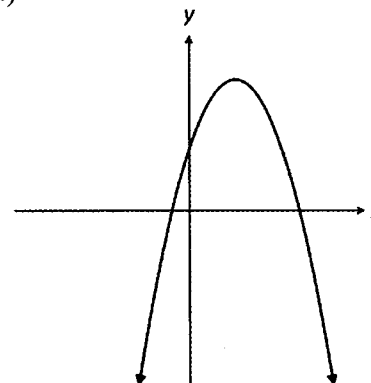

5.5 Rational Functions

- A rational function takes the form $f(x) = \frac{P(x)}{Q(x)}$

where $P(x)$ and $Q(x)$ are polynomials.

- $f(x) = \frac{P(x)}{Q(x)}$ is a *proper* rational function if the degree of the polynomial $P(x)$ is strictly less than the degree of the polynomial $Q(x)$.
- For the curve with equation $y = \frac{P(x)}{Q(x)}$:
 - the vertical asymptotes (poles) correspond to the roots of $Q(x) = 0$.
 - the horizontal asymptote corresponds to $\lim_{x \rightarrow +\infty} \frac{P(x)}{Q(x)}$ and/or $\lim_{x \rightarrow -\infty} \frac{P(x)}{Q(x)}$.
 - if $P(x)$ and $Q(x)$ share a common factor $(x + a)$, then the curve has a “hole” or discontinuity (singularity) at $x = -a$.

Example 5.11

Find the horizontal and vertical asymptotes for the following:

$$(a) y = \frac{1}{2x-3} + 4 \quad (b) y = \frac{2x}{x+2} \quad (c) y = \frac{-3x}{(x-2)(x+2)} \quad (d) y = \frac{4x^3}{(x-3)(x+4)}$$

Solution:

(a) Denominator $2x - 3 = 0 \Rightarrow x = 1.5$

Hence, equation of the vertical asymptote is $x = 1.5$.

For the horizontal asymptote: $\lim_{x \rightarrow -\infty} f(x) = 4$ and $\lim_{x \rightarrow +\infty} f(x) = 4$

Hence, the equation of the horizontal asymptote is $y = 4$.

(b) Equation of the vertical asymptote is $x = -2$.

$\frac{2x}{x+2}$ is an improper rational fraction; using polynomial division: $\frac{2x}{x+2} \equiv -\frac{4}{x+2} + 2$

For the horizontal asymptote: $\lim_{x \rightarrow -\infty} f(x) = 2$ and $\lim_{x \rightarrow +\infty} f(x) = 2$

Hence, the equation of the horizontal asymptote is $y = 2$.

Alternative Method for finding the horizontal asymptote

The dominant term in the numerator is $2x$

while the dominant term in the denominator is x .

Hence, $\lim_{x \rightarrow -\infty} f(x) = \lim_{x \rightarrow -\infty} \frac{2x}{x} = 2$.

\Rightarrow Equation of the horizontal asymptote is $y = 2$.

(c) Equation of vertical asymptotes are $x = -2$ and $x = 2$.

Using the dominant term method: $\lim_{x \rightarrow -\infty} f(x) = \lim_{x \rightarrow -\infty} \frac{-3x}{x^2} = 0$.

Hence, equation of the horizontal asymptote is $y = 0$.

(d) Equation of vertical asymptotes are $x = -4$ and $x = 3$.

Using the dominant term method: $\lim_{x \rightarrow -\infty} f(x) = \lim_{x \rightarrow -\infty} \frac{4x^3}{x^2} \rightarrow -\infty$

and $\lim_{x \rightarrow +\infty} f(x) = \lim_{x \rightarrow +\infty} \frac{4x^3}{x^2} \rightarrow +\infty$

The limit in each case does not exist. Hence, there is no horizontal asymptote.

Example 5.12

Without the use of a calculator, sketch: (a) $y = \frac{2x}{(x-4)(x+2)}$ (b) $y = \frac{2(2-x)(x+3)}{x^2-4}$

Solution:

(a)

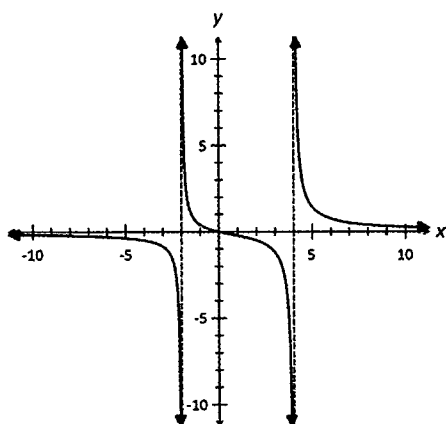

- Obvious points: $x = 0 \Rightarrow y = 0$
- Vertical asymptote: $x = -2, 4$
- Horizontal asymptote: $y = \lim_{x \rightarrow -\infty} \frac{2x}{x^2} = 0$.
- Behaviour of curve in the neighbourhood of the asymptotes
 - As $x \rightarrow 4^-$, $y \rightarrow -\infty$
 - As $x \rightarrow 4^+$, $y \rightarrow +\infty$
 - As $x \rightarrow -2^-$, $y \rightarrow -\infty$
 - As $x \rightarrow -2^+$, $y \rightarrow +\infty$
 - As $x \rightarrow -\infty$, $y \rightarrow 0^+$
 - As $x \rightarrow +\infty$, $y \rightarrow 0^+$

(b)

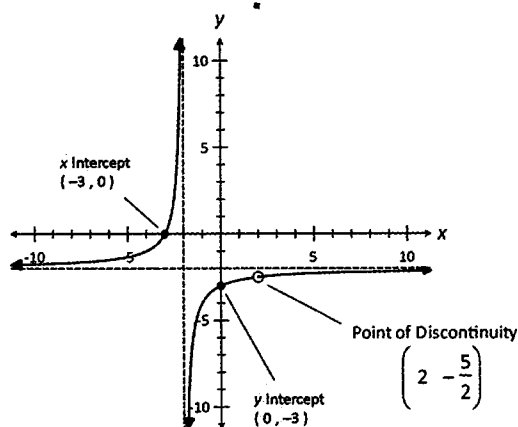

- Simplify equation: $y = \frac{2(2-x)(x+3)}{x^2-4} = \frac{2(2-x)(x+3)}{(x-2)(x+2)} = \frac{-2(x+3)}{(x+2)} \quad x \neq 2$
- As $x \neq 2$, the point $(2, -\frac{5}{2})$ is a "hole".
[It is a point of discontinuity/singularity.]
- Obvious points: $x = 0 \Rightarrow y = -3$
 $y = 0 \Rightarrow x = -3$
- Vertical asymptote: $x = -2$
- Horizontal asymptote: $y = \lim_{x \rightarrow -\infty} \frac{-2x}{x} = -2$.

Example 5.13

The sketch of $y = \frac{(x+a)(x-b)}{cx^2+d}$ is given in the accompanying diagram. Find the values of the constants a , b , c and d , where $a > 0$, $b > 0$ and $c > 0$.

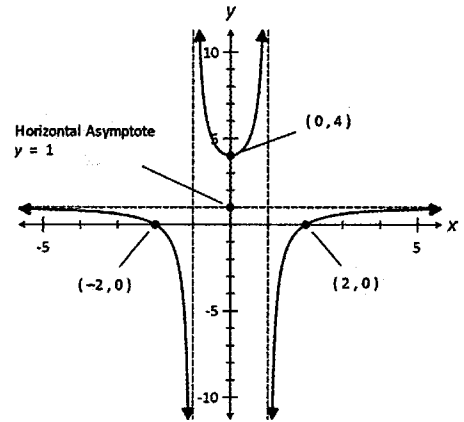
Solution:

The curve has zeros at $x = -2$ and 2 .

$$\Rightarrow y = \frac{(x+2)(x-2)}{cx^2+d}$$

That is $a = 2$ and $b = 2$.

The curve has a vertical intercept at $y = 4$.

$$\text{Hence, } 4 = \frac{-4}{d} \Rightarrow d = -1.$$

The curve has a horizontal asymptote with equation $y = 1$.

$$\Rightarrow \lim_{x \rightarrow +\infty} \frac{x^2}{cx^2} = 1$$

$$c = 1.$$

Hence, $a = 2$, $b = 2$, $c = 1$ and $d = -1$.

Example 5.14

Consider the curve with equation $y = \frac{ax+b}{x+c}$. Find the constants a , b and c , where $a > 0$, if the curve has an asymptote with equation $x = -2$, a zero at $x = 2$ and an intercept at $(0, -2)$.

Solution:

$$x = -2 \text{ is an asymptote: } \Rightarrow c = 2$$

$$\text{Hence, equation of curve is } y = \frac{ax+b}{x+2}$$

$$\text{When } x = 0, y = -2 \quad \Rightarrow \frac{b}{2} = -2 \quad \Rightarrow b = -4.$$

$$\text{When } x = 2, y = 0 \quad \Rightarrow \frac{2a-4}{4} = 0 \quad \Rightarrow a = 2.$$

Hence, $a = 2$, $b = -4$ and $c = 2$.

Example 5.15

Consider the curve with equation $y = \frac{4x-5}{x^2-1}$. Without the use of a calculator:

- (a) find the intercepts and asymptotes of the curve.
 (b) express $\frac{dy}{dx}$ in the form $\frac{-k(ax+b)(cx+d)}{(x^2-1)^2}$, where $a > 0$ and $c > 0$.
 (c) find the coordinates and nature of the stationary points of this curve.
 (d) sketch this curve and indicate clearly the intercepts, asymptotes and stationary points.

Solution:

$$y = \frac{4x-5}{x^2-1} = \frac{4x-5}{(x-1)(x+1)}$$

- (a) When $x = 0, y = 5$. Hence, the y -intercept has coordinates $(0, 5)$.
 When $y = 0, x = \frac{5}{4}$. Hence, the x -intercept has coordinates $(\frac{5}{4}, 0)$.

Vertical asymptotes has equations $x = -1$ and $x = 1$.

Horizontal asymptote has equation $y = \lim_{x \rightarrow +\infty} \frac{4x}{x^2} = 0$.

(b)
$$\begin{aligned} \frac{dy}{dx} &= \frac{4(x^2-1) - 2x(4x-5)}{(x^2-1)^2} \\ &= \frac{-4x^2 + 10x - 4}{(x^2-1)^2} = \frac{-2(2x-1)(x-2)}{(x^2-1)^2} \end{aligned}$$

(c) For stationary points, $\frac{dy}{dx} = 0$.

Hence, $(2x-1)(x-2) = 0 \Rightarrow x = \frac{1}{2}, 2$

When $x = \frac{1}{2}, y = 4$ and when $x = 2, y = 1$.

Use the sign test for $x = \frac{1}{2}$.

Hence $(\frac{1}{2}, 4)$ is a minimum point.

Use the sign test for $x = 2$

Hence, $(2, 1)$ is a maximum point.

x	$\frac{1}{2}^-$	$\frac{1}{2}$	$\frac{1}{2}^+$
$\frac{dy}{dx}$	-	0	+

x	2^-	2	2^+
$\frac{dy}{dx}$	+	0	-

(d) The sketch of the curve is given below.

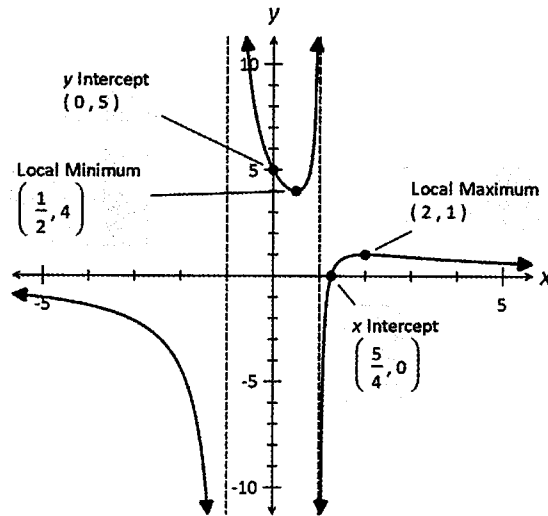

Example 5.16

The rational function $f(x)$ has the following properties:

$$f(-1) = f(3) = 0, f(0) = -3, f'(x) > 0 \text{ for } x > 1, f'(x) < 0 \text{ for } x < 1,$$

$$\lim_{x \rightarrow -\infty} f(x) = \lim_{x \rightarrow +\infty} f(x) = 1, \lim_{x \rightarrow 1^-} f(x) \rightarrow -\infty \text{ and } \lim_{x \rightarrow 1^+} f(x) \rightarrow -\infty.$$

Sketch the graph of $y = f(x)$.

Solution:

$$f(-1) = f(3) = 0$$

\Rightarrow x -intercepts are $(-1, 0)$ and $(3, 0)$.

$$f(0) = -3$$

\Rightarrow y -intercept is $(0, -3)$.

$$\lim_{x \rightarrow -\infty} f(x) = \lim_{x \rightarrow +\infty} f(x) = 1$$

\Rightarrow Horizontal asymptote has equation $y = 1$.

$$\lim_{x \rightarrow 1^-} f(x) = -\infty \text{ and } \lim_{x \rightarrow 1^+} f(x) = -\infty$$

\Rightarrow Vertical asymptote has equation $x = 1$.

The sketch of $y = f(x)$ is given in the accompanying diagram.

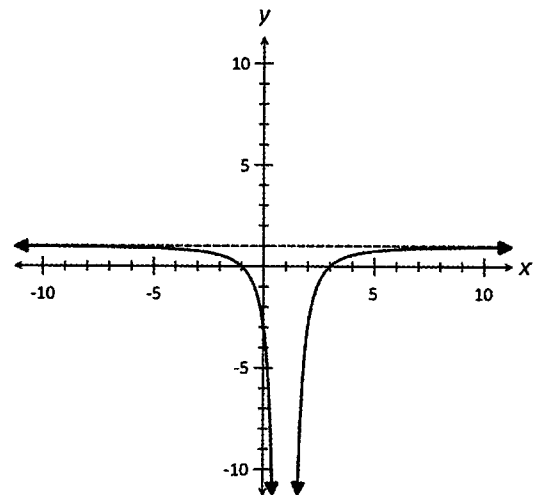

Note:

- $x = 1$ is a double asymptote.

Exercise 5.3

1. For each of the following rational functions, without the use of a calculator:

- (i) state the coordinates of the intercepts (where they exist)
 (ii) state the equations of the horizontal and vertical asymptotes
 (iii) hence, sketch the graphs of these functions.

(a) $y = \frac{x+3}{x-3}$

(b) $y = \frac{4-2x}{x-4}$

(c) $y = \frac{6-2x}{x+3}$

(d) $y = \frac{2x-8}{2+x}$

(e) $y = \frac{4x}{(x-2)(x+2)}$

(f) $y = \frac{3x+15}{(3-x)(x+5)}$

(g) $y = \frac{3x+6}{(3-x)(x+2)}$

(h) $y = \frac{6x+9}{x^2-9}$

2. The graphs of the rational functions $y = \frac{P(x)}{Q(x)}$ where $P(x)$ and $Q(x)$ are both linear factors are drawn below. In each case:

- (i) identify the equation of the curve (ii) sketch $y = |f(x)|$ (iii) Sketch $y = \frac{1}{f(x)}$.

(a)

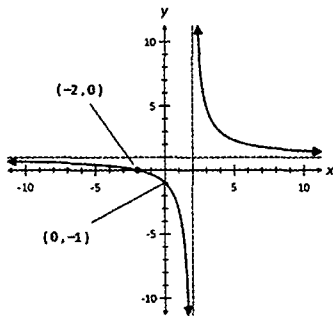

(b)

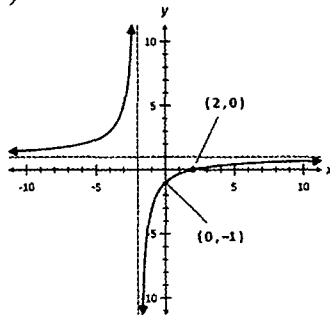

(c)

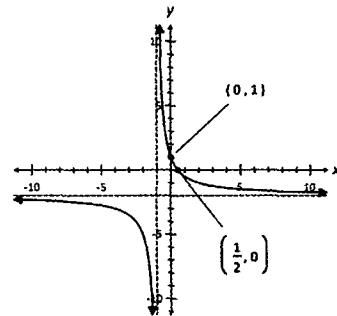

3. The sketch of $y = f(x) = \frac{ax+b}{c-x^2}$ is given in the accompanying diagram.

- (a) Find the values of the constants a , b and c where $a > 0$.
 (b) Sketch $y = |f(x)|$.
 (c) Sketch $y = \frac{1}{f(x)}$.

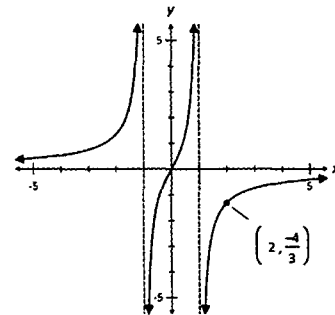

4. The sketch of $y = \frac{ax+b}{cx^2+dx}$ is given in the accompanying diagram.

- (a) Find a possible set of values for the constants a , b , c and d .
 (b) Sketch $y = |f(x)|$.
 (c) Sketch $y = \frac{1}{f(x)}$.

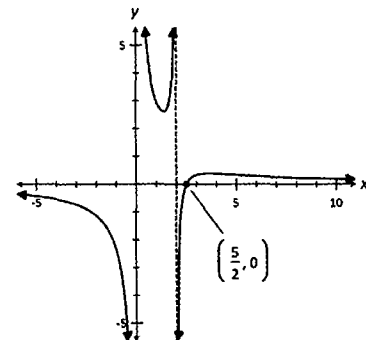

5. The sketch of $y = \frac{(a-x)(x+b)}{(x+c)(x+d)}$ is given in the accompanying diagram.

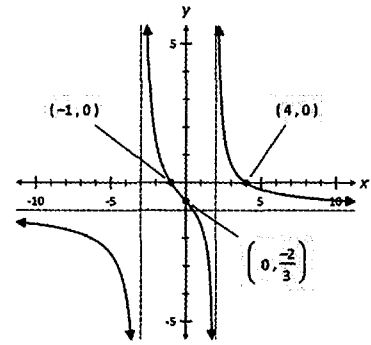

- (a) Find the values of the constants a , b , c and d , where $a > 0$ and $c > d$.

(b) Sketch $y = |f(x)|$.

(c) Sketch $y = \frac{1}{f(x)}$.

6. The curve $y = \frac{ax+b}{cx+d}$ has asymptotes with equation $x = 2$, $y = -\frac{1}{2}$ and a zero at $x = 1$.

Find a possible set of values for a , b , c and d .

7. The curve $y = \frac{ax+b}{(x+c)(x+d)}$ has a zero at $x = \frac{1}{2}$ and a y -intercept at $(0, \frac{1}{3})$

asymptotes with equations $x = 1$ and $x = -3$. Find a , b , c and d , where $c > d$.

8. The curve $y = \frac{(x+a)(x+b)}{(2x+c)(x+d)}$ has a zero at $x = 1$, a y -intercept at $(0, \frac{1}{2})$ and asymptotes

with equations $x = 2$, $x = -\frac{1}{2}$ and $y = \frac{1}{2}$. Find all possible sets of values for a , b , c and d .

9. The curve $y = \frac{(ax+b)(cx+d)}{(x+e)(x+f)}$ has a zero at $x = 1$ and a y -intercept at $(0, \frac{2}{9})$, an

asymptote with equation $y = 1$ and poles at $x = 3$ and $x = -3$, Find a possible set of values for the integers a , b , c , d , e and f , where $e > f$.

10. Consider the curve with equation $y = \frac{x^2}{x^2-4}$. Without the use of a calculator:

(a) find the intercepts and asymptotes of this curve.

(b) show that $\frac{dy}{dx} = \frac{ax}{(x^2-4)^2}$, giving the value of a .

(c) find the coordinates and nature of the stationary points of this curve.

(d) sketch this curve and indicate clearly the intercepts, asymptotes and stationary points.

11. Consider the curve with equation $y = \frac{x}{x^2+1}$. Without the use of a calculator:

(a) find the intercepts and asymptotes of this curve.

(b) show that $\frac{dy}{dx} = \frac{a-bx^2}{(x^2+1)^2}$, where $a > 0$, giving the values of a and b .

(c) find the coordinates and nature of the stationary points of this curve.

(d) sketch this curve and indicate clearly the intercepts, asymptotes and stationary points.

12. Consider the curve with equation $y = \frac{2x^2 + 800}{x}$. Without the use of a calculator:
- find the intercepts and asymptotes of the curve.
 - show that $\frac{dy}{dx} = \frac{ax^2 + b}{x^2}$, where $a > 0$, giving the value of a .
 - find the coordinates and nature of the stationary points of this curve.
 - sketch this curve and indicate clearly the intercepts, asymptotes and stationary points.
13. Consider the curve with equation $y = \frac{x^2 + 3}{x^2 + 3x}$. Without the use of a calculator:
- find the intercepts and asymptotes of this curve.
 - show that $\frac{dy}{dx} = \frac{3(x+a)(x+b)}{(x^2 + 3x)^2}$, giving the values of a and b .
 - find the coordinates and nature of the stationary points of this curve.
 - sketch this curve and indicate clearly the intercepts, asymptotes and stationary points.
14. Sketch the graph of the rational function $f(x)$ given that it has the following properties
- $f(0) = f'(0) = 0$
 - $f'(x) > 0$ for $x < -2$ and $-2 < x < 0$
 - $\lim_{x \rightarrow 2^-} f(x) = \lim_{x \rightarrow -2^+} f(x) \rightarrow -\infty$
 - $\lim_{x \rightarrow -\infty} f(x) = \lim_{x \rightarrow +\infty} f(x) = 1$
 - $f'(x) < 0$ for $0 < x < 2$ and $x > 2$
 - $\lim_{x \rightarrow -2^-} f(x) = \lim_{x \rightarrow 2^+} f(x) \rightarrow \infty$
15. Sketch the graph of the rational function $f(x)$ given that it has the following properties:
- $f(0) = f'(0) = f''(0) = 0$
 - $\lim_{x \rightarrow -3^-} f(x) = \lim_{x \rightarrow 3^-} f(x) \rightarrow -\infty$
 - $\lim_{x \rightarrow -\infty} f(x) = \lim_{x \rightarrow +\infty} f(x) = 0$
 - $f'(x) < 0$ for all values of x except 0 and ± 3
 - $\lim_{x \rightarrow 3^+} f(x) = \lim_{x \rightarrow -3^+} f(x) \rightarrow \infty$
16. Sketch the graph of the rational function $f(x)$ given that it has the following properties
- $f(1) = f(-1) = f'(0) = 0$
 - $f'(x) > 0$ for $x < 0$
 - $f'(x) < 0$ for $x > 0$
 - $\lim_{x \rightarrow -\infty} f(x) = \lim_{x \rightarrow +\infty} f(x) = -1$
17. Sketch the graph of the rational function $f(x)$ given that it has the following properties
- $f(0) = 0, f'(0) = f'\left(\frac{4}{3}\right) = 0$
 - $f'(x) > 0$ for $0 < x < 1$ and $1 < x < \frac{4}{3}$
 - $f'(x) < 0$ for $x < 0, \frac{4}{3} < x < 2$ and $x > 2$
 - $\lim_{x \rightarrow -\infty} f(x) = \lim_{x \rightarrow +\infty} f(x) = 1$
 - $\lim_{x \rightarrow 1^-} f(x) = \lim_{x \rightarrow 2^+} f(x) \rightarrow \infty$
 - $\lim_{x \rightarrow 2^-} f(x) = \lim_{x \rightarrow 1^+} f(x) \rightarrow -\infty$

5.5.1 Rational functions with oblique asymptotes

- $\frac{P(x)}{Q(x)}$ is a proper rational fraction if the degree of the polynomial $P(x)$ is strictly less than the degree of the polynomial $Q(x)$.

- Consider a rational function of the form $f(x) = \frac{P(x)}{Q(x)} + ax + b$

where $\frac{P(x)}{Q(x)}$ is a proper rational fraction and the constant $a \neq 0$.

- The vertical asymptotes (poles) correspond to the roots of $Q(x) = 0$.
- This function may or may not have any horizontal asymptote.
- This function has an oblique asymptote with equation $y = ax + b$.
 - As $x \rightarrow \pm \infty$, as $\frac{P(x)}{Q(x)}$ is a proper rational fraction, $\frac{P(x)}{Q(x)} \rightarrow 0$ and $f(x) \rightarrow ax + b$.
 - As $x \rightarrow \pm \infty$, the curve “hugs” the line with equation $y = ax + b$.

Example 5.17

Consider the curve with equation $y = \frac{x^2 + 3x - 4}{x + 1}$. Without the use of a calculator:

- express $y \equiv \frac{P(x)}{Q(x)} + ax + b$ where $\frac{P(x)}{Q(x)}$ is a rational proper fraction and $a \neq 0$.
- state the coordinates of all intercepts and the equations of all asymptotes of this curve.
- sketch this curve, indicating all essential features.

Solution:

- Using polynomial division:

$$\text{Hence, } y = \frac{x^2 + 3x - 4}{x + 1} \equiv \frac{-6}{x + 1} + x + 2.$$

$$\begin{array}{r} x + 2 \\ x + 1 \overline{) x^2 + 3x - 4} \\ \underline{x^2 + x} \\ 2x - 4 \\ \underline{2x + 2} \\ -6 \end{array}$$

$$\begin{aligned} \text{Or by inspection: } \frac{x^2 + 3x - 4}{x + 1} &\equiv \frac{x \times (x + 1) + 2 \times (x + 1) - 6}{x + 1} \\ &\equiv \frac{(x + 1)(x + 2) - 6}{x + 1} \\ &\equiv \frac{-6}{x + 1} + x + 2. \end{aligned}$$

- When $x = 0, y = -4$. Hence, the y -intercept has coordinates $(0, -4)$.
When $y = 0, x^2 + 3x - 4 \equiv (x + 4)(x - 1) = 0 \Rightarrow x = -4, 1$
Hence, the x -intercept has coordinates $(-4, 0)$ and $(1, 0)$.

Vertical asymptote has equation $x = -1$.

Oblique asymptote has equation $y = x + 2$.

- (c) The sketch of the curve is given in the accompanying diagram.

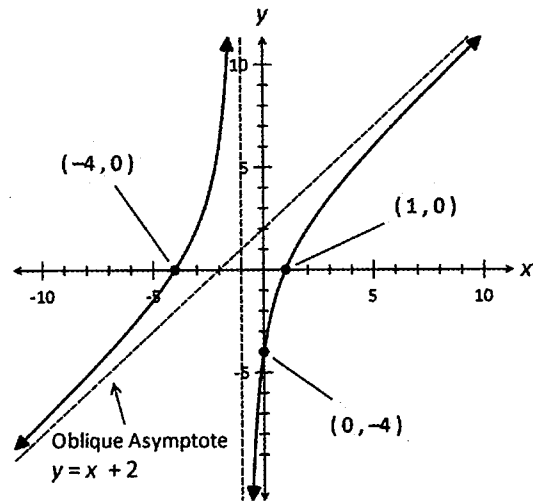

Exercise 5.4

1. For each of the following curves $y = f(x)$, without the use of a calculator:

(i) express $y \equiv \frac{P(x)}{Q(x)} + ax + b$ where $\frac{P(x)}{Q(x)}$ is a rational proper fraction and $a \neq 0$.

(ii) state the coordinates of all intercepts and the equations of all asymptotes

(iii) sketch this curve, indicating all essential features.

(a) $y = \frac{(x+1)(x-2)}{x-1}$ (b) $y = \frac{(2-x)(x+3)}{x+2}$ (c) $y = \frac{x^2+3x-4}{x+2}$ (d) $y = \frac{x^2-5x+4}{x-2}$

2. For each of the following curves $y = f(x)$, without the use of a calculator:

(i) express $y \equiv \frac{P(x)}{Q(x)} + ax + b$ where $\frac{P(x)}{Q(x)}$ is a rational proper fraction and $a \neq 0$.

(ii) state the coordinates of all intercepts and the equations of all asymptotes

(iii) state the coordinates and nature of the stationary point(s)

(iv) sketch this curve, indicating all essential features.

(a) $y = \frac{x^2+1}{x}$ (b) $y = \frac{-x^2-x-1}{x}$ (c) $y = \frac{x^2-3}{x-2}$ *(d) $y = \frac{x^3}{x^2-1}$

- *3. The sketch of $y = \frac{x^3 + bx^2 + cx + d}{x^2 + n}$ is given in the accompanying diagram.

(a) State the equation of the oblique asymptote.

(b) Find the values of the constants b , c , d and n .

(c) Sketch $y = |f(x)|$.

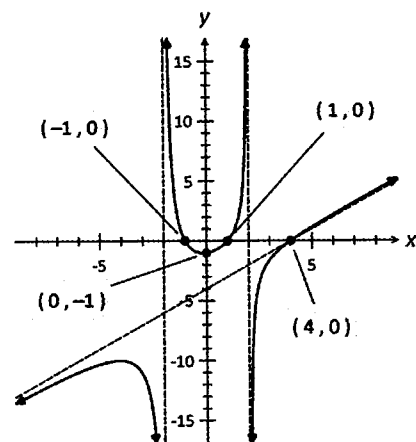

06 Vectors I

6.1 Vectors in Three Dimensional Space

- The accompanying diagram shows the x - y - z axes in three dimensional space. The axes are mutually perpendicular to each other. In this book, the convention used in labelling the axes follows the right-hand rule.

- Straighten all your fingers keeping them together (with the thumb perpendicular to the fingers) so that the open palm is aligned with the x -axis and the fingers point in the direction of the positive x -axis.*
- Wave your fingers with a 90° turn (without moving your thumb) so that the open palm is now at right angles to the x -axis. The direction of your fingers is the direction of the positive y -axis.*
- Move your hand in the direction of your thumb. This is direction of the positive z -axis.*

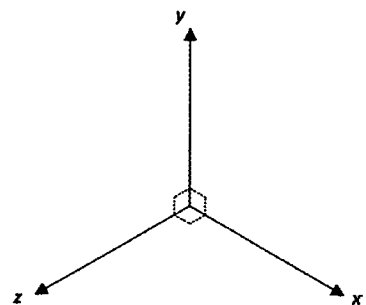
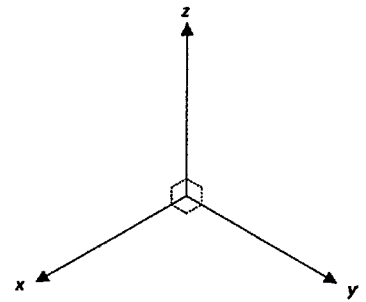

- As in the case of the x - y axes, the point of intersection between the x , y and z axes is called the origin.
- Each point in space can be described by a set of three numbers (x, y, z) . For example, $(1, 2, 3)$ locates the position of a point P which is 1 unit, 2 units and 3 units respectively in the direction of the positive x -axis, positive y -axis and positive z -axis.
- If the origin O has coordinates $(0, 0, 0)$ and the point P has coordinates $(1, 2, 3)$, then the position vector of P , denoted $\mathbf{OP} = i + 2j + 3k$ where i, j and k are unit vectors in the positive x , positive y and positive z directions respectively.

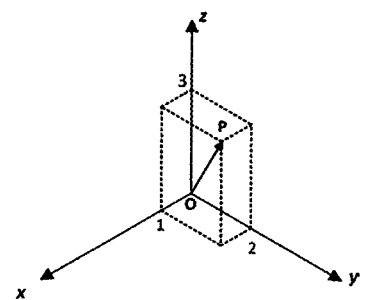
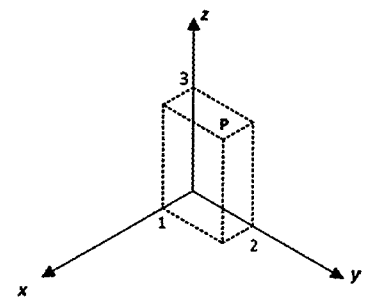

Alternatively $\mathbf{OP} = \langle 1, 2, 3 \rangle$ or $\mathbf{OP} = \begin{pmatrix} 1 \\ 2 \\ 3 \end{pmatrix}$.

- Note that $\mathbf{u} = \langle 1, 2, 3 \rangle$ represents a free (floating) vector parallel to \mathbf{OP} .
- Using Pythagoras Theorem, the magnitude of \mathbf{OP} , $|\mathbf{OP}| = \sqrt{1^2 + 2^2 + 3^2} = \sqrt{14}$.

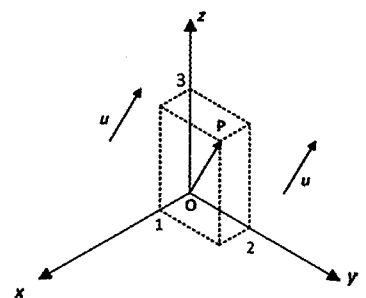

6.1.1 Magnitude and Orientation

- In general, if $\mathbf{u} = \langle a, b, c \rangle$,
 - then the magnitude of \mathbf{u} is given by

$$|\mathbf{u}| = \sqrt{a^2 + b^2 + c^2}.$$
 - The orientation (or direction) of \mathbf{u} is described using direction cosines:

$$\langle \cos \alpha, \cos \beta, \cos \gamma \rangle \equiv \left\langle \frac{a}{|\mathbf{u}|}, \frac{b}{|\mathbf{u}|}, \frac{c}{|\mathbf{u}|} \right\rangle$$

where α , β and γ are the angles \mathbf{u} makes with the x -axis, y -axis and z -axis respectively. This, however, is beyond the scope of this book.

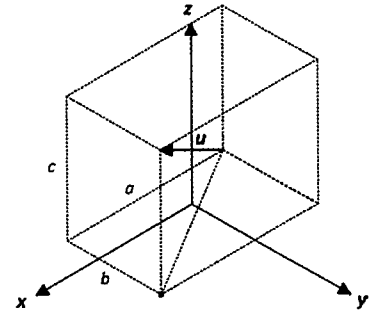

6.2 Algebraic & Geometrical Properties of 3D vectors

- The algebraic and geometrical properties of 2D and 3D vectors are similar.
- The vector $k\mathbf{a}$ where k is a constant, is a vector parallel to \mathbf{a} but with a magnitude that is $|k|$ times that of \mathbf{a} . That is $|k\mathbf{a}| = |k| \times |\mathbf{a}|$
 - If $k > 0$, then $k\mathbf{a}$ and \mathbf{a} are in the same direction.
 - If $k < 0$, then $k\mathbf{a}$ and \mathbf{a} are parallel but in opposing directions.
- Unit vector parallel to \mathbf{a} , $\hat{\mathbf{a}} = \frac{1}{|\mathbf{a}|} \mathbf{a}$.
- Given that $\mathbf{u} = a\mathbf{i} + b\mathbf{j} + c\mathbf{k}$ and $\mathbf{v} = p\mathbf{i} + q\mathbf{j} + r\mathbf{k}$, then:
 - $\mathbf{u} \pm \mathbf{v} = (a \pm p)\mathbf{i} + (b \pm q)\mathbf{j} + (c \pm r)\mathbf{k}$
 - the scalar product is: $(a\mathbf{i} + b\mathbf{j} + c\mathbf{k}) \cdot (p\mathbf{i} + q\mathbf{j} + r\mathbf{k}) = ap + bq + cr$
- Properties of the scalar product:
 - $\mathbf{u} \cdot \mathbf{u} = |\mathbf{u}|^2$
 - $\mathbf{u} \cdot \mathbf{v} = \mathbf{v} \cdot \mathbf{u}$
 - $\lambda\mathbf{u} \cdot \mu\mathbf{v} = \lambda\mu(\mathbf{u} \cdot \mathbf{v})$
 - $(\mathbf{u} + \mathbf{v}) \cdot \mathbf{w} = \mathbf{u} \cdot \mathbf{w} + \mathbf{v} \cdot \mathbf{w}$
 - $\mathbf{w} \cdot (\mathbf{u} + \mathbf{v}) = \mathbf{w} \cdot \mathbf{u} + \mathbf{w} \cdot \mathbf{v}$
 - $(\mathbf{e} + \mathbf{f}) \cdot (\mathbf{g} + \mathbf{h}) = \mathbf{e} \cdot \mathbf{g} + \mathbf{e} \cdot \mathbf{h} + \mathbf{f} \cdot \mathbf{g} + \mathbf{f} \cdot \mathbf{h}$
- Consider two vectors \mathbf{u} and \mathbf{v} , inclined at an angle of θ to each other.
 - The scalar product $\mathbf{u} \cdot \mathbf{v} = |\mathbf{u}| \times |\mathbf{v}| \cos \theta$.
 - $\cos \theta = \frac{\mathbf{u} \cdot \mathbf{v}}{|\mathbf{u}| \times |\mathbf{v}|}$.
 - \mathbf{u} and \mathbf{v} are perpendicular $\Leftrightarrow \mathbf{u} \cdot \mathbf{v} = 0$.
 - The scalar projection of \mathbf{u} onto $\mathbf{v} = \mathbf{u} \cdot \hat{\mathbf{v}}$.
 - The vector projection of \mathbf{u} onto \mathbf{v} , $\text{proj}_{\mathbf{v}} \mathbf{u} = (|\mathbf{u}| \cos \theta) \hat{\mathbf{v}} = (\mathbf{u} \cdot \hat{\mathbf{v}}) \hat{\mathbf{v}}$.

Example 6.1

In the accompanying diagram, draw and indicate the line segments representing the vectors:

- (a) $u + v$ (b) $u - v$.

Solution:

(a)

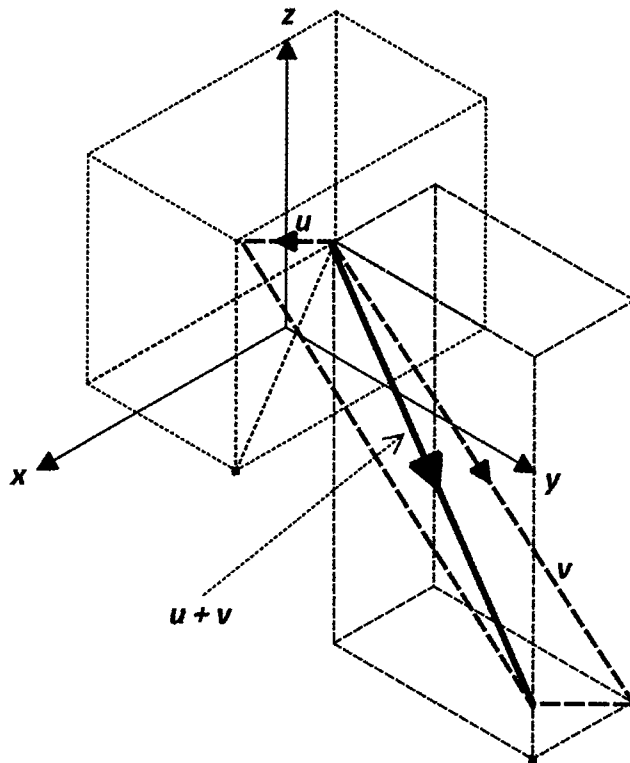

(b)

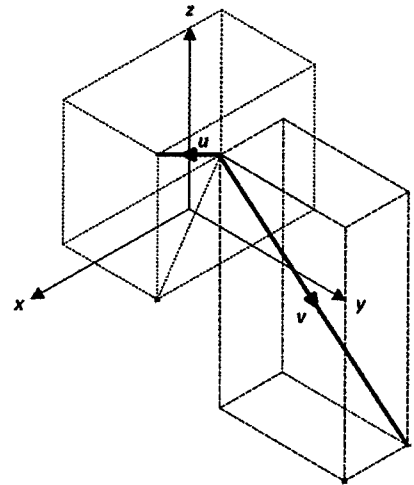
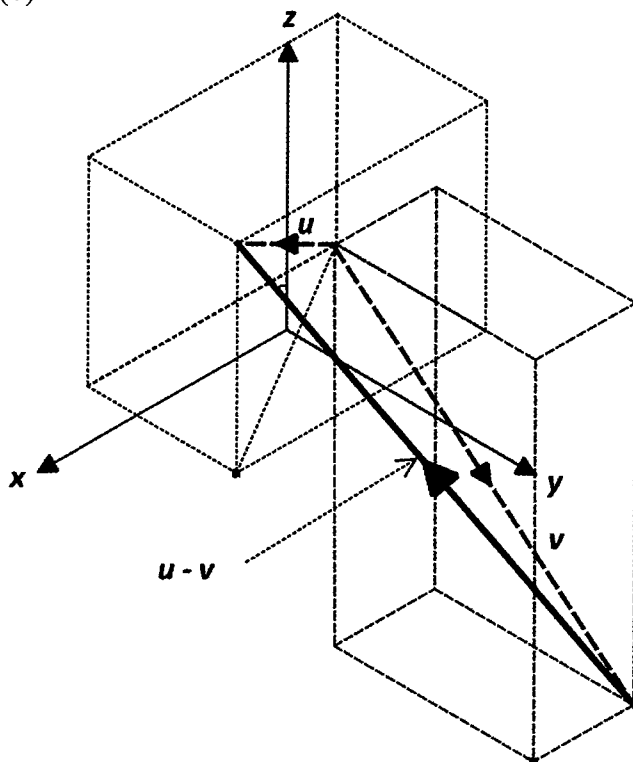

Note:

In vector addition, the arrow that completes the triangle always points from the tail of the first vector to the tip of the second vector.

Note:

In vector subtraction, the arrow that completes the triangle always points to the first vector, which in this case is u .

Example 6.2

Given that $\mathbf{AB} = \langle 6, 5, 10 \rangle$ and $\mathbf{AC} = \langle 3, 11, 1 \rangle$, find the position vector of B if the position vector of C is $\langle 10, -3, 4 \rangle$.

Solution:

$$\begin{aligned}\mathbf{AC} &= \mathbf{OC} - \mathbf{OA} \Rightarrow \langle 3, 11, 1 \rangle = \langle 10, -3, 4 \rangle - \mathbf{OA} \Rightarrow \mathbf{OA} = \langle 7, -14, 3 \rangle \\ \mathbf{AB} &= \mathbf{OB} - \mathbf{OA} \Rightarrow \langle 6, 5, 10 \rangle = \mathbf{OB} - \langle 7, -14, 3 \rangle \Rightarrow \mathbf{OB} = \langle 13, -9, 13 \rangle\end{aligned}$$

That is, the position vector of B is $\langle 13, -9, 13 \rangle$.

Example 6.3

The points A, B and C have position vectors $\langle -1, 2, 0 \rangle$, $\langle 2, -5, 3 \rangle$ and $\langle 0, 4, -3 \rangle$ respectively. Find: (a) \mathbf{BC} (b) $|\mathbf{AB}|$ (c) the distance between A and B.

Solution:

(a) $\mathbf{BC} = \mathbf{OC} - \mathbf{OB} = \langle 0, 4, -3 \rangle - \langle 2, -5, 3 \rangle = \langle -2, 9, -6 \rangle$.

(b) $\mathbf{AB} = \mathbf{OB} - \mathbf{OA} = \langle 2, -5, 3 \rangle - \langle -1, 2, 0 \rangle = \langle 3, -7, 3 \rangle$.

Hence, $|\mathbf{AB}| = \sqrt{3^2 + (-7)^2 + 3^2} = \sqrt{67}$.

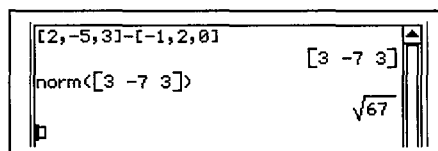

Calculator screenshot showing the calculation of the magnitude of vector AB. The input is $\text{norm}([3 \ -7 \ 3])$ and the result is $\sqrt{67}$.

(c) The distance between A and B = $|\mathbf{AB}| = \sqrt{67}$.

Example 6.4

The points P, Q and R have position vectors $\langle 5, -2, -1 \rangle$, $\langle -3, 4, 3 \rangle$ and $\langle -3, 6, 1 \rangle$ respectively. Find:

(a) $|\mathbf{PQ}|$ (b) $|\mathbf{PR}|$ (c) a vector parallel to \mathbf{PQ} but with the same magnitude as \mathbf{PR} .

Solution:

(a) $\mathbf{PQ} = \langle -3, 4, 3 \rangle - \langle 5, -2, -1 \rangle = \langle -8, 6, 4 \rangle$.

Hence, $|\mathbf{PQ}| = \sqrt{(-8)^2 + 6^2 + 4^2} = 2\sqrt{29}$.

(b) $\mathbf{PR} = \langle -3, 6, 1 \rangle - \langle 5, -2, -1 \rangle = \langle -8, 8, 2 \rangle$.

Hence, $|\mathbf{PR}| = \sqrt{(-8)^2 + 8^2 + 2^2} = 2\sqrt{33}$.

(c) Unit vector in the direction of \mathbf{PR}

$$= \frac{1}{2\sqrt{33}} \langle -8, 8, 2 \rangle$$

Hence, required vector is $2\sqrt{29} \times \frac{1}{2\sqrt{33}} \langle -8, 8, 2 \rangle = \frac{\sqrt{957}}{33} \langle -8, 8, 2 \rangle$.

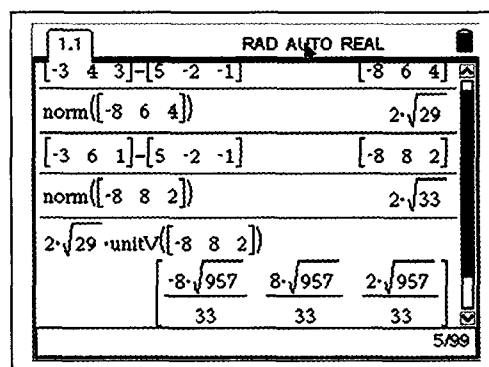

Calculator screenshot showing the calculation of the unit vector in the direction of \mathbf{PR} . The input is $2\sqrt{29} \cdot \text{unitV}([-8 \ 8 \ 2])$ and the result is $\frac{-8\sqrt{957}}{33} \quad \frac{8\sqrt{957}}{33} \quad \frac{2\sqrt{957}}{33}$.

Example 6.5

Find a and b if that the points $P(a, 5, 10)$, $Q(3, 8, 5)$ and $R(5, -1, b)$ are collinear.

Solution:

$$\mathbf{PQ} = \mathbf{OQ} - \mathbf{OP} = \begin{pmatrix} 3 \\ 8 \\ 5 \end{pmatrix} - \begin{pmatrix} a \\ 5 \\ 10 \end{pmatrix} = \begin{pmatrix} 3-a \\ 3 \\ -5 \end{pmatrix} \quad \mathbf{PR} = \mathbf{OR} - \mathbf{OP} = \begin{pmatrix} 5 \\ -1 \\ b \end{pmatrix} - \begin{pmatrix} a \\ 5 \\ 10 \end{pmatrix} = \begin{pmatrix} 5-a \\ -6 \\ b-10 \end{pmatrix}.$$

Since, P , Q and R are collinear, then the line segments PQ and PR must be parallel.

That is $\mathbf{PQ} = \lambda \mathbf{PR}$. Hence $\Rightarrow \begin{pmatrix} 3-a \\ 3 \\ -5 \end{pmatrix} = \lambda \begin{pmatrix} 5-a \\ -6 \\ b-10 \end{pmatrix}$.

Comparing j components $3 = -6\lambda \Rightarrow \lambda = -\frac{1}{2}$

Comparing i components $\Rightarrow 3 - a = -\frac{1}{2}(5 - a) \Rightarrow a = \frac{11}{3}$

Comparing k components $-5 = -\frac{1}{2}(b - 10) \Rightarrow b = 20$

Example 6.6

The points A and B have position vectors $\langle 3, 5, 10 \rangle$ and $\langle 10, -6, 20 \rangle$ respectively. Find the position vector of the point K if K divides the line segment AB in the ratio 3:1.

Solution:

From the given sketch:

$$\mathbf{AK} = \frac{3}{4} \mathbf{AB} \Rightarrow 4 \mathbf{AK} = 3 \mathbf{AB}$$

$$4(\mathbf{OK} - \mathbf{OA}) = 3(\mathbf{OB} - \mathbf{OA})$$

$$\Rightarrow \mathbf{OK} = \frac{1}{4}(\mathbf{OA} + 3\mathbf{OB})$$

$$\mathbf{OK} = \frac{1}{4}[\langle 3, 5, 10 \rangle + 3\langle 10, -6, 20 \rangle] = \frac{1}{4} \langle 33, -13, 70 \rangle$$

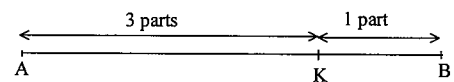

Example 6.7

Find the acute angle between $\langle 2, 3, 4 \rangle$ and $\langle -3, 5, 2 \rangle$.

Solution:

Let the angle between the two vectors be θ .

$$\text{Then, } \cos \theta = \frac{\langle 2, 3, 4 \rangle \cdot \langle -3, 5, 2 \rangle}{|\langle 2, 3, 4 \rangle| |\langle -3, 5, 2 \rangle|} = \frac{17}{\sqrt{29}\sqrt{38}}$$

$$\Rightarrow \theta = 59.2^\circ$$

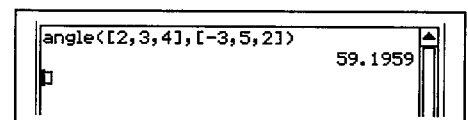

Example 6.8

Find a vector of magnitude 20 which is perpendicular to $\langle 4, 5, -2 \rangle$.

Solution:

$\langle 2, 0, 4 \rangle$ is perpendicular to $\langle 4, 5, -2 \rangle$ as $\langle 2, 0, 4 \rangle \cdot \langle 4, 5, -2 \rangle = 0$.

Unit vector parallel to $\langle 2, 0, 4 \rangle$ is $\frac{1}{\sqrt{20}} \langle 2, 0, 4 \rangle$.

Hence, required vector = $20 \times \frac{1}{\sqrt{20}} \langle 2, 0, 4 \rangle$
 $= \sqrt{20} \langle 2, 0, 4 \rangle$.

Note:

- There are an infinite number of vectors that are perpendicular to $\langle 4, 5, -2 \rangle$.

Example 6.9

Given $\mathbf{u} = \langle 4, 0, 2 \rangle$ and $\mathbf{v} = \langle 3, \sqrt{3}, 2 \rangle$.

- (a) Find the scalar projection of \mathbf{u} onto \mathbf{v} . (b) Find the vector projection of \mathbf{u} onto \mathbf{v} .
 (c) Find the vector rejection of \mathbf{u} onto \mathbf{v} .

Solution:

$$(a) \quad \mathbf{v} = \langle 3, \sqrt{3}, 2 \rangle \quad \Rightarrow \quad \hat{\mathbf{v}} = \frac{1}{4} \langle 3, \sqrt{3}, 2 \rangle.$$

$$\begin{aligned} \Rightarrow \text{Scalar projection of } \mathbf{u} \text{ onto } \mathbf{v} &= \mathbf{u} \cdot \hat{\mathbf{v}} \\ &= \langle 4, 0, 2 \rangle \cdot \frac{1}{4} \langle 3, \sqrt{3}, 2 \rangle \\ &= 4. \end{aligned}$$

$$\begin{aligned} (b) \quad \text{proj}_{\mathbf{v}} \mathbf{u} &= (\mathbf{u} \cdot \hat{\mathbf{v}}) \hat{\mathbf{v}} \\ &= 4 \times \frac{1}{4} \langle 3, \sqrt{3}, 2 \rangle \\ &= \langle 3, \sqrt{3}, 2 \rangle. \end{aligned}$$

$$\begin{aligned} (c) \quad \text{rej}_{\mathbf{v}} \mathbf{u} &= \langle 4, 0, 2 \rangle - \langle 3, \sqrt{3}, 2 \rangle \\ &= \langle 1, -\sqrt{3}, 0 \rangle. \end{aligned}$$

Exercise 6.1

1. In the accompanying diagram, draw and indicate the line segments representing the vectors $u + v$ and $u - v$.

(a)

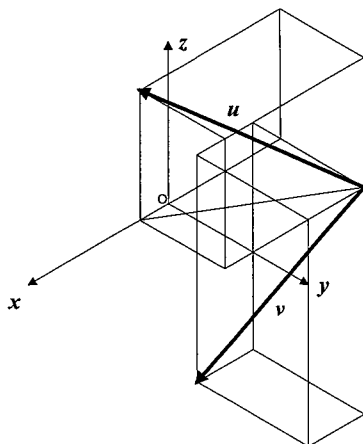

(b)

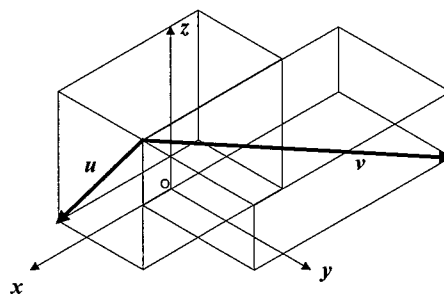

2. Point A has position vector $6i - 4j + 8k$. $AB = 4i + 7j - 6k$. Find the position vector of: (a) the point B. (b) the point C given that $2AC = BA$.
3. The position vectors of P and Q are $\langle -2, 3, k \rangle$ and $\langle 4, -5, 10 \rangle$ respectively.
 (a) Find the value(s) of k if $|OP| = 20$. (b) Find the value(s) of k if $|PQ| = 20$.
4. Given that $PQ = \langle 8, -5, 2 \rangle$ and $PR = \langle 4, 1, -7 \rangle$, find the position vector of Q if the position vector of R is $\langle 4, -2, -1 \rangle$.
5. The points K and L have position vectors $\langle 0, 3, -4 \rangle$ and $\langle 5, 0, 3 \rangle$.
 (a) Find a unit vector parallel to KL .
 (b) Find a vector in the same direction as LK but with a magnitude of 10.
6. The points A, B and C have coordinates $(1, 1, 2)$, $(0, 1, -1)$ and $(1, 0, -2)$ respectively.
 (a) Find a vector that is parallel to AB but with the same magnitude as AC .
 (b) Find a vector that is parallel to AC with magnitude half that of BC .
7. The points E, F and G have position vectors $\langle -2, 5, 3 \rangle$, $\langle 0, 0, 2 \rangle$ and $\langle -3, 5, 7 \rangle$ respectively.
 (a) Find a vector that is the same direction as EF but with the same magnitude as FG .
 (b) Find a vector that acts in a direction opposing EG and with a magnitude of 10.
8. Find in exact form a unit vector parallel to $u = \langle -k, k, 2k \rangle$, where $k \geq 0$.
 Hence, find in exact form a vector
 (a) parallel and in the same direction as u with magnitude 5
 (b) parallel but in the opposite direction to u with magnitude 10
9. Given that $a = i - k$ and $b = -j + k$, find two vectors parallel to $a + 2b$ with magnitude equal to that of b .

23. Let $\mathbf{u} = \langle 1, a, 2 \rangle$ and $\mathbf{v} = \langle -1, b, -2 \rangle$.
Find a and b if $|\mathbf{u}| = |\mathbf{v}|$ and \mathbf{u} and \mathbf{v} are perpendicular.
24. Let $\mathbf{u} = \langle a, b, 3 \rangle$ and $\mathbf{v} = \langle 4, a, 3 \rangle$.
Find a and b if $|\mathbf{v}| = |\mathbf{u}|$ and \mathbf{u} and \mathbf{v} are perpendicular.
- *25. Use a method involving scalar products to find a and b if the acute angle between $\langle 1, 0, 1 \rangle$ and $\langle a, b, 0 \rangle$ is 60° . Hint: Let $\langle a, b, 0 \rangle$ be a unit vector.
- *26. Use a method involving scalar products to prove that no vector of the form $\langle a, 0, b \rangle$ is inclined at angle of 60° with the vector $\langle 1, 2, 0 \rangle$, where a and b are real numbers.
27. Given $\mathbf{u} = \langle 1, 1, 1 \rangle$ and $\mathbf{v} = \langle 2, 2, -1 \rangle$. Without the use of a calculator, find the vector projection of: (a) \mathbf{u} onto \mathbf{v} (b) \mathbf{v} onto \mathbf{u} .
28. Given $\mathbf{u} = \langle 0, 1, 2 \rangle$ and $\mathbf{v} = \langle 2, -1, -2 \rangle$. Without the use of a calculator, find the vector projection of: (a) \mathbf{u} onto \mathbf{v} (b) \mathbf{v} onto \mathbf{u} .
29. Given $\mathbf{u} = \langle 1, 2, 0 \rangle$ and $\mathbf{v} = \langle 3, 2, \sqrt{3} \rangle$. Without the use of a calculator, find the vector rejection of \mathbf{u} onto \mathbf{v} .
30. Given $\mathbf{u} = \langle -2, -2, 1 \rangle$ and $\mathbf{v} = \langle 0, 2, 3 \rangle$. Without the use of a calculator, find the vector rejection of \mathbf{v} onto \mathbf{u} .
31. Given that $\mathbf{u} = \langle 1, 0, 1 \rangle + \langle 0, -1, 0 \rangle$, find the vector projection and rejection of \mathbf{u} onto: (a) $\langle 2, -2, 2 \rangle$ (b) $\langle -5, 5, -5 \rangle$.
32. Given that $\mathbf{u} = \langle 2, 1, 3 \rangle + \langle 3, -9, 1 \rangle$, find the vector projection and rejection of \mathbf{u} onto: (a) $\langle 4, 2, 6 \rangle$ (b) $\langle -3, 9, -1 \rangle$.
33. Given that the vector projection and rejection of \mathbf{u} onto \mathbf{v} are $\langle 3, 5, -2 \rangle$ and $\langle 2, 0, 3 \rangle$ respectively, find the cosine of the angle between \mathbf{u} and \mathbf{v} .
34. Given that the vector projection and rejection of \mathbf{u} onto \mathbf{v} are $\langle 5, 1, -2 \rangle$ and $\langle 1, 11, 8 \rangle$ respectively, find the cosine of the acute between \mathbf{u} and \mathbf{v} .
35. The vector components of \mathbf{u} parallel and perpendicular to \mathbf{v} are $\langle 1, 2, 2 \rangle$ and $\langle 2, -2, 1 \rangle$ respectively. Without the use of a calculator, find the cosine of the angle between \mathbf{u} and \mathbf{v} .

6.3 Vector Cross Product

- Let $\mathbf{u} = \begin{pmatrix} a \\ b \\ c \end{pmatrix}$ and $\mathbf{v} = \begin{pmatrix} p \\ q \\ r \end{pmatrix}$.
- The *cross product* between \mathbf{u} and \mathbf{v} is a *vector* that is perpendicular/normal to both \mathbf{u} and \mathbf{v} . The direction of the cross product is determined using the right hand rule.
- The cross product is represented by $\mathbf{u} \times \mathbf{v}$ and is given by:

$$\begin{pmatrix} a \\ b \\ c \end{pmatrix} \times \begin{pmatrix} p \\ q \\ r \end{pmatrix} = \begin{pmatrix} \begin{vmatrix} b & q \\ c & r \end{vmatrix} \\ - \begin{vmatrix} a & p \\ c & r \end{vmatrix} \\ \begin{vmatrix} a & p \\ b & q \end{vmatrix} \end{pmatrix} = \begin{pmatrix} br - cq \\ -(ar - cp) \\ aq - bp \end{pmatrix}$$

Determinant of matrix formed by the j and k components of u and v.

Negative of determinant of matrix formed by the i and k components of u and v.

Determinant of matrix formed by the i and j components of u and v.

- Clearly from the x-y-z axes:
 $\mathbf{i} \times \mathbf{j} = \mathbf{k} \quad \mathbf{j} \times \mathbf{k} = \mathbf{i} \quad \mathbf{k} \times \mathbf{i} = \mathbf{j}$
- The vector cross product is anti-commutative.
 That is: $\mathbf{u} \times \mathbf{v} = -(\mathbf{v} \times \mathbf{u})$.
- The vector cross product is distributive over vector addition .
 That is: $\mathbf{u} \times (\mathbf{v} + \mathbf{w}) = \mathbf{u} \times \mathbf{v} + \mathbf{u} \times \mathbf{w}$.
- $|\mathbf{u} \times \mathbf{v}| = |\mathbf{u}| |\mathbf{v}| \sin \theta$, where θ is the acute angle between \mathbf{u} and \mathbf{v} .
 [The proof of this result is required in Exercise 6.2, question 16.]
 - Clearly, if \mathbf{u} is parallel to \mathbf{v} , $\theta = 0$ or π and $|\mathbf{u} \times \mathbf{v}| = 0$.
 That is, the cross product between two parallel vectors is always zero.
 - Conversely, if the cross product between two vectors is zero, then the two vectors are parallel.
- The area of the parallelogram defined by the vectors \mathbf{u} and \mathbf{v} is $|\mathbf{u} \times \mathbf{v}|$.
 [The proof of this result is given elsewhere in this book.]
 - That is, the area of the parallelogram defined by the vectors \mathbf{u} and \mathbf{v} is given by the magnitude of the cross product between \mathbf{u} and \mathbf{v} .

Example 6.10

Prove that: (a) $i \times j = k$ (b) $j \times k = i$ (c) $k \times i = j$

Solution:

$$(a) \ i \times j = \begin{pmatrix} 1 \\ 0 \\ 0 \end{pmatrix} \times \begin{pmatrix} 0 \\ 1 \\ 0 \end{pmatrix} = \begin{pmatrix} \begin{vmatrix} 0 & 1 \\ 0 & 0 \end{vmatrix} \\ -\begin{vmatrix} 1 & 0 \\ 0 & 0 \end{vmatrix} \\ \begin{vmatrix} 1 & 0 \\ 0 & 1 \end{vmatrix} \end{pmatrix} = \begin{pmatrix} 0 \\ 0 \\ 1 \end{pmatrix} = k$$

$$(b) \ j \times k = \begin{pmatrix} 0 \\ 1 \\ 0 \end{pmatrix} \times \begin{pmatrix} 0 \\ 0 \\ 1 \end{pmatrix} = \begin{pmatrix} \begin{vmatrix} 1 & 0 \\ 0 & 1 \end{vmatrix} \\ -\begin{vmatrix} 0 & 0 \\ 0 & 1 \end{vmatrix} \\ \begin{vmatrix} 0 & 0 \\ 1 & 0 \end{vmatrix} \end{pmatrix} = \begin{pmatrix} 1 \\ 0 \\ 0 \end{pmatrix} = i$$

$$(c) \ k \times i = \begin{pmatrix} 0 \\ 0 \\ 1 \end{pmatrix} \times \begin{pmatrix} 1 \\ 0 \\ 0 \end{pmatrix} = \begin{pmatrix} \begin{vmatrix} 0 & 0 \\ 1 & 0 \end{vmatrix} \\ -\begin{vmatrix} 0 & 1 \\ 1 & 0 \end{vmatrix} \\ \begin{vmatrix} 0 & 1 \\ 0 & 0 \end{vmatrix} \end{pmatrix} = \begin{pmatrix} 0 \\ 1 \\ 0 \end{pmatrix} = j$$

Example 6.11

Prove that $i \times j = -(j \times i)$

Solution:

$$\text{RHS} = -(j \times i)$$

$$= - \left[\begin{pmatrix} 0 \\ 1 \\ 0 \end{pmatrix} \times \begin{pmatrix} 1 \\ 0 \\ 0 \end{pmatrix} \right] = - \begin{pmatrix} \begin{vmatrix} 1 & 0 \\ 0 & 0 \end{vmatrix} \\ -\begin{vmatrix} 0 & 1 \\ 0 & 0 \end{vmatrix} \\ \begin{vmatrix} 0 & 1 \\ 1 & 0 \end{vmatrix} \end{pmatrix} = - \begin{pmatrix} 0 \\ 0 \\ -1 \end{pmatrix}$$

$$= k$$

$$= i \times j = \text{LHS}$$

Example 6.12

Without the use of a calculator, find a vector of magnitude 50 that is normal to both $\langle 1, 3, -1 \rangle$ and $\langle 2, 1, 1 \rangle$.

Solution:

$$\begin{pmatrix} 1 \\ 3 \\ -1 \end{pmatrix} \times \begin{pmatrix} 2 \\ 1 \\ 1 \end{pmatrix} = \begin{pmatrix} \begin{vmatrix} 3 & 1 \\ -1 & 1 \end{vmatrix} \\ -\begin{vmatrix} 1 & 2 \\ -1 & 1 \end{vmatrix} \\ \begin{vmatrix} 1 & 2 \\ 3 & 1 \end{vmatrix} \end{pmatrix} = \begin{pmatrix} 4 \\ -3 \\ -5 \end{pmatrix}$$

$$\text{Hence, required vector} = 50 \times \frac{1}{\sqrt{50}} \begin{pmatrix} 4 \\ -3 \\ -5 \end{pmatrix} = \sqrt{50} \begin{pmatrix} 4 \\ -3 \\ -5 \end{pmatrix}.$$

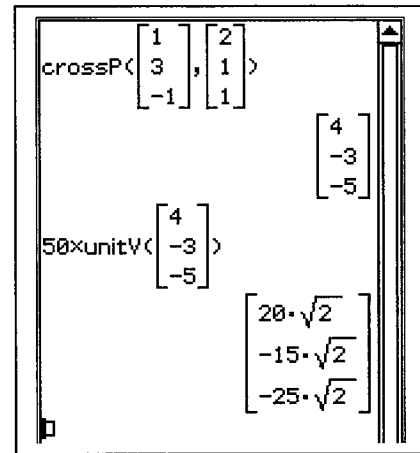

Note:

- The word “normal” means perpendicular.

Example 6.13

Given $\langle 1, -1, 1 \rangle \times \langle 2, m, n \rangle = \langle 1, 4, 3 \rangle$ find m and n .

Solution:

$$\langle 1, -1, 1 \rangle \times \langle 2, m, n \rangle = \langle 1, 4, 3 \rangle$$

$$\left\langle \begin{vmatrix} -1 & m \\ 1 & n \end{vmatrix}, -\begin{vmatrix} 1 & 2 \\ 1 & n \end{vmatrix}, \begin{vmatrix} 1 & 2 \\ -1 & m \end{vmatrix} \right\rangle = \langle 1, 4, 3 \rangle$$

$$\langle -n - m, -n + 2, m + 2 \rangle = \langle 1, 4, 3 \rangle$$

$$\Rightarrow \begin{aligned} m &= 1 \\ n &= -2 \end{aligned}$$

Example 6.14

The angle between the vectors \mathbf{a} and \mathbf{b} is 60° , find $|\mathbf{a} \times \mathbf{b}|$ if $|\mathbf{a}| = 10$ and $|\mathbf{b}| = \sqrt{3}$.

Solution:

$$\begin{aligned} |\mathbf{a} \times \mathbf{b}| &= |\mathbf{a}| |\mathbf{b}| \sin 60^\circ \\ &= 10 \times \sqrt{3} \times \frac{\sqrt{3}}{2} = 15 \end{aligned}$$

Example 6.15

Let $\mathbf{u} = \langle 2, 2, 1 \rangle$ and $\mathbf{v} = \langle 2, 1, 2 \rangle$. Without the use of a calculator:

- (a) find $\sin \theta$, where θ is the acute angle between \mathbf{u} and \mathbf{v} .
 (b) verify that $|\mathbf{u} \times \mathbf{v}| = |\mathbf{u}| |\mathbf{v}| \sin \theta$.

Solution:

$$\begin{aligned} \text{(a)} \quad \cos \theta &= \frac{\langle 2, 2, 1 \rangle \cdot \langle 2, 1, 2 \rangle}{|\langle 2, 2, 1 \rangle| |\langle 2, 1, 2 \rangle|} \\ &= \frac{8}{9} \end{aligned}$$

$$\text{Hence,} \quad \sin \theta = \sqrt{1 - \left(\frac{8}{9}\right)^2} = \frac{\sqrt{17}}{9}$$

$$\begin{aligned} \text{(b)} \quad |\mathbf{u} \times \mathbf{v}| &= |\langle 2, 2, 1 \rangle \times \langle 2, 1, 2 \rangle| \\ &= \left| \left\langle \begin{vmatrix} 2 & 1 \\ 1 & 2 \end{vmatrix}, -\begin{vmatrix} 2 & 2 \\ 1 & 2 \end{vmatrix}, \begin{vmatrix} 2 & 2 \\ 2 & 1 \end{vmatrix} \right\rangle \right| \\ &= |\langle 3, -2, -2 \rangle| = \sqrt{17} \end{aligned}$$

$$|\mathbf{u}| |\mathbf{v}| \sin \theta = 3 \times 3 \times \frac{\sqrt{17}}{9} = \sqrt{17}$$

$$\text{Hence,} \quad |\mathbf{u} \times \mathbf{v}| = |\mathbf{u}| |\mathbf{v}| \sin \theta$$

Example 6.16

The sides OA and CB of a parallelogram OABC are congruent to the vector $\langle 1, 2, 2 \rangle$. The remaining two sides are congruent to the vector $\langle 1, 0, 1 \rangle$. Without the use of a calculator, find the area of: (a) the parallelogram OABC (b) the triangle OAB.

Solution:

$$\begin{aligned} \text{(a) Area of OABC} &= |\langle 1, 2, 2 \rangle \times \langle 1, 0, 1 \rangle| \\ &= \left| \left\langle \begin{vmatrix} 2 & 0 \\ 2 & 1 \end{vmatrix}, -\begin{vmatrix} 1 & 1 \\ 2 & 1 \end{vmatrix}, \begin{vmatrix} 1 & 1 \\ 2 & 0 \end{vmatrix} \right\rangle \right| \\ &= |\langle 2, 1, -2 \rangle| = 3 \text{ units}^2 \end{aligned}$$

$$\text{(b) Area of } \triangle OAB = \frac{1}{2} \times \text{Area of OABC} = \frac{3}{2} \text{ units}^2$$

Exercise 6.2

1. Without the use of a calculator, prove that: (a) $k \times j = -i$. (b) $i \times k = -j$.
2. Without the use of a calculator, prove that:
(a) $(2i) \times (3j) = 6k$ (b) $(i+j) \times k = i-j$ (c) $i \times (j+k) = -j+k$.
3. Without the use of a calculator, find a vector that is perpendicular to both:
(a) $2i+j+2k$ and $3i-2j+k$ (b) $-i+2j-3k$ and $4i-3k$.
4. Without the use of a calculator, find a unit vector that is normal to both $\langle 1, 2, 1 \rangle$ and $\langle -1, 1, 2 \rangle$.
5. Without the use of a calculator, find a vector of magnitude 30 that is perpendicular to both $\langle 1, 1, 0 \rangle$ and $\langle 1, 0, 1 \rangle$.
6. Find the value of the pronumerals in each of the following:
(a) $\langle 2, a, 3 \rangle \times \langle 2, b, -1 \rangle = \langle -2, 8, 4 \rangle$
(b) $\langle 1, -1, m \rangle \times \langle n, -1, 3 \rangle = \langle -1, 1, 1 \rangle$
(c) $\langle a, b, 0 \rangle \times \langle 4, -1, 2 \rangle = \langle -4, -6, 5 \rangle$.
(d) $\langle 1, -3, 2 \rangle \times \langle a, -1, b \rangle = \langle 14, 10, 8 \rangle$.
7. The angle between the vectors a and b is 45° , find $|a \times b|$ if $|a| = 20$ and $|b| = 2\sqrt{2}$.
8. The angle between the vectors a and b is 150° , find $|b \times a|$ if $|a| = 2$ and $|b| = 4$.
9. The angle between the vectors a and b is 120° , find $|a \times b|$ if $|a| = \sqrt{3}$ and $|b| = 12$.
10. Without the use of a calculator, use a vector cross-product to find $\sin \theta$, where θ is the acute angle between: (a) $\langle 2, 1, -1 \rangle$ and $\langle 3, 0, 4 \rangle$ (b) $\langle -1, 2, -4 \rangle$ and $\langle 1, -1, 3 \rangle$.
11. Without the use of a calculator, use a vector cross-product to find $\cos \theta$, where θ is the acute angle between $\langle 3, 0, 1 \rangle$ and $\langle 0, 2, -1 \rangle$.
12. The sides OA and CB of a parallelogram OABC are congruent to the vector $\langle 3, -4, 0 \rangle$. The remaining two sides are congruent to the vector $\langle 1, 2, 2 \rangle$. Without the use of a calculator, find the area of: (a) the parallelogram OABC (b) the triangle OAB.
13. The sides PQ and SR of a parallelogram PQRS are congruent to the vector $\langle 1, 2, 4 \rangle$. The remaining two sides are congruent to the vector $\langle 3, -2, 2 \rangle$. Without the use of a calculator, find the area of: (a) the parallelogram PQRS (b) the triangle PSR.
14. Prove that: (a) $u \times v = -v \times u$
(b) $mu \times nv = mn(u \times v)$ where m and n are scalar constants.
15. Prove that: (a) $(a+b) \times c = (a \times c) + (b \times c)$ (b) $a \times (b+c) = (a \times b) + (a \times c)$
- *16. Prove that $|a \times b|^2 = |a|^2 |b|^2 - (a \cdot b)^2$. Hence, prove that $|a \times b| = |a| |b| \sin \theta$.

07 Vectors II

7.1 Vector Equation of a Line

- Consider the line L which passes through the fixed point A and which is parallel to vector d .
- Let the position vector of the point A be $\mathbf{OA} = a$.
- Let R be a variable point on the line L. Let the position vector of R be $\mathbf{OR} = r$.
- Clearly $\mathbf{OR} = \mathbf{OA} + \mathbf{AR}$.
- Since line L is parallel to d , \mathbf{AR} must be parallel to d . Hence, $\mathbf{AR} = \lambda d$.
- Therefore, $r = a + \lambda d$.

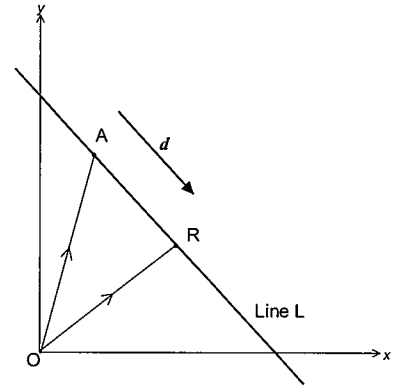

That is, the position vector of any point on the line L can be written in this form.

- Consider now the line L in 3D space which passes through the fixed point A and which is parallel to vector d .
- Let the position vector of the point A be $\mathbf{OA} = a$.
- Let R be a variable point on the line L. Let the position vector of R be $\mathbf{OR} = r$.
- Clearly $\mathbf{OR} = \mathbf{OA} + \mathbf{AR}$.
- Since line L is parallel to d , \mathbf{AR} must be parallel to d . Hence, $\mathbf{AR} = \lambda d$.
- Therefore, $r = a + \lambda d$.

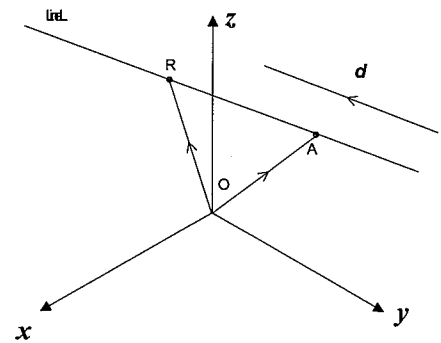

That is, the position vector of any point on the line L can be written in this form.

- Hence, the vector equation of a line passing through the fixed point with position vector a and parallel to d is given by:

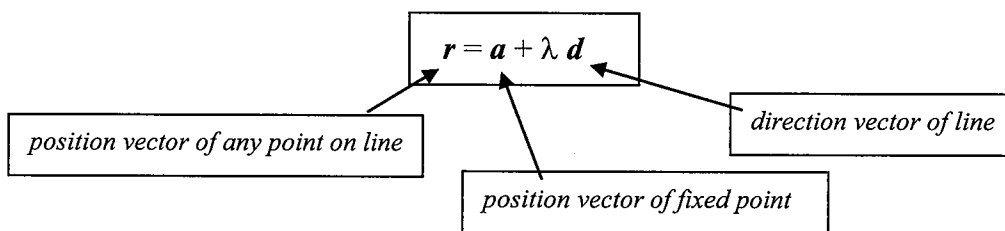

Example 7.1

Find the vector equation of the line passing through the point with position vector $-2\mathbf{i} + 3\mathbf{j} + 6\mathbf{k}$ and:

- (a) parallel to the vector $\mathbf{i} - \mathbf{j} + 2\mathbf{k}$ (b) the point with position vector $\mathbf{i} + 6\mathbf{j} - \mathbf{k}$.

Solution:

(a) Vector equation of line is $\mathbf{r} = (-2\mathbf{i} + 3\mathbf{j} + 6\mathbf{k}) + \lambda(\mathbf{i} - \mathbf{j} + 2\mathbf{k})$
 $= (-2 + \lambda)\mathbf{i} + (3 - \lambda)\mathbf{j} + (6 + 2\lambda)\mathbf{k}$

- (b) The required line passes through the points with position vectors $-2\mathbf{i} + 3\mathbf{j} + 6\mathbf{k}$ and $\mathbf{i} + 6\mathbf{j} - \mathbf{k}$.

Hence, the direction vector of the line is of the form

$$(-2\mathbf{i} + 3\mathbf{j} + 6\mathbf{k}) - (\mathbf{i} + 6\mathbf{j} - \mathbf{k}) = -3\mathbf{i} - 3\mathbf{j} + 7\mathbf{k}$$

Therefore a possible vector equation of the required line is

$$\mathbf{r} = (-2\mathbf{i} + 3\mathbf{j} + 6\mathbf{k}) + \lambda(-3\mathbf{i} - 3\mathbf{j} + 7\mathbf{k}) = (-2 - 3\lambda)\mathbf{i} + (3 - 3\lambda)\mathbf{j} + (6 + 7\lambda)\mathbf{k}$$

Example 7.2

Determine if the point with position vector $\langle -1, -6, 5 \rangle$ lies on the line $\mathbf{r} = \langle -1, 2, -3 \rangle + \lambda \langle 0, -5, 5 \rangle$.

Solution:

Since \mathbf{r} represents the position vector of any point on the line, then $\mathbf{r} = \langle -1, -6, 5 \rangle$ must satisfy

$$\mathbf{r} = \langle -1, 2, -3 \rangle + \lambda \langle 0, -5, 5 \rangle.$$

Consider $\langle -1, -6, 5 \rangle = \langle -1, 2, -3 \rangle + \lambda \langle 0, -5, 5 \rangle$.

Comparing i -components: $-1 = -1$

Comparing j -components: $2 - 5\lambda = -6 \Rightarrow \lambda = 1.6$

Comparing k -components: $-3 + 5\lambda = 5 \Rightarrow \lambda = 1.6$

Therefore, $\mathbf{r} = \langle -1, -6, 5 \rangle$ satisfies the equation $\mathbf{r} = \langle -1, 2, -3 \rangle + \lambda \langle 0, -5, 5 \rangle$.

That is, the point with position vector $\langle -1, -6, 5 \rangle$ lies on the given line.

Example 7.3

A line has equation $y = 4x - 5$. Find the vector equation of this line.

Solution:

The gradient of the given line is 4. Hence, this line is parallel to $\langle 1, 4 \rangle$.

An obvious point on the given line is the vertical intercept $(0, -5)$.

Hence, the given line passes through $(0, -5)$ and is parallel to $\langle 1, 4 \rangle$.

Therefore, its vector equation is $\mathbf{r} = \langle 0, -5 \rangle + \lambda \langle 1, 4 \rangle$.

Note:

- Gradient = 4 means one unit to the "right" is accompanied by 4 units "upwards".
Hence, line is parallel to $\langle 1, 4 \rangle$.

Example 7.4

Use a vector method to find the position vector of the point of intersection between the lines $r = \langle -1, 1, 3 \rangle + \lambda \langle 1, 2, 1 \rangle$ and $r = \langle 2, 1, 8 \rangle + \lambda \langle 1, -1, 2 \rangle$.

Solution:

Rewrite equations as $r = \langle -1, 1, 3 \rangle + \lambda \langle 1, 2, 1 \rangle$
 $= \langle -1 + \lambda, 1 + 2\lambda, 3 + \lambda \rangle$
 and $r = \langle 2, 1, 8 \rangle + \mu \langle 1, -1, 2 \rangle$
 $= \langle 2 + \mu, 1 - \mu, 8 + 2\mu \rangle$.

At the point of intersection,
 $\langle -1 + \lambda, 1 + 2\lambda, 3 + \lambda \rangle = \langle 2 + \mu, 1 - \mu, 8 + 2\mu \rangle$.

Comparing components: $-1 + \lambda = 2 + \mu$ (I)
 $1 + 2\lambda = 1 - \mu$ (II)
 $3 + \lambda = 8 + 2\mu$ (III)

The two lines are traced as the value of λ changes. However, they do not have to "trace" at the same pace. Hence, start by changing the " λ " in the second equation into " μ ". This makes sure that the two lines trace independently.

Solve I and II simultaneously: $\lambda = 1, \mu = -2$.

Substitute $\lambda = 1, \mu = -2$ into (III), a true statement is obtained.

Hence, the two lines meet at $\langle 0, 3, 4 \rangle$.

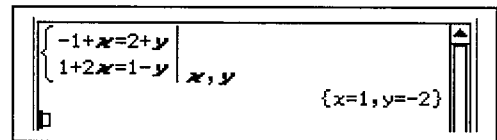

Example 7.5

Use a vector method to show that the lines with equations $r = \langle 1, -1, 2 \rangle + \lambda \langle -2, 1, 1 \rangle$ and $r = \langle 1, 1, -1 \rangle + \lambda \langle 3, -1, 1 \rangle$ are non-intersecting.

Solution:

Rewrite equations as $r = \langle 1 - 2\lambda, -1 + \lambda, 2 + \lambda \rangle$
 and $r = \langle 1 + 3\mu, 1 - \mu, -1 + \mu \rangle$.

At the point of intersection,
 $\langle 1 - 2\lambda, -1 + \lambda, 2 + \lambda \rangle = \langle 1 + 3\mu, 1 - \mu, -1 + \mu \rangle$.

Comparing components: $1 - 2\lambda = 1 + 3\mu$ (I)
 $-1 + \lambda = 1 - \mu$ (II)
 $2 + \lambda = -1 + \mu$ (III)

Solve I and II simultaneously: $\lambda = 6, \mu = -4$.

Substitute $\lambda = 6, \mu = -4$ into (III), a false statement is obtained.

Hence, the two lines do not intersect.

7.1.1 Parametric Equation of a Line in 3D

- The vector equation of the line L passing through the point with position vector \mathbf{a} and parallel to vector \mathbf{d} is given by $\mathbf{r} = \mathbf{a} + \lambda\mathbf{d}$.

- In 3D space, let $\mathbf{r} = \begin{pmatrix} x \\ y \\ z \end{pmatrix}$, $\mathbf{a} = \begin{pmatrix} a_1 \\ a_2 \\ a_3 \end{pmatrix}$ and $\mathbf{d} = \begin{pmatrix} d_1 \\ d_2 \\ d_3 \end{pmatrix}$.

- Hence, the equation of the line can be written as $\begin{pmatrix} x \\ y \\ z \end{pmatrix} = \begin{pmatrix} a_1 \\ a_2 \\ a_3 \end{pmatrix} + \lambda \begin{pmatrix} d_1 \\ d_2 \\ d_3 \end{pmatrix}$.

- Comparing the i, j and k components:

$$\begin{aligned} x &= a_1 + \lambda d_1 \\ y &= a_2 + \lambda d_2 \\ z &= a_3 + \lambda d_3 \end{aligned}$$

This set of three equations is referred to as the parametric equation of the line L .

7.1.2 Cartesian Equation of a Line in 3D

- The vector equation of the line L passing through the point with position vector \mathbf{a} and parallel to vector \mathbf{d} is given by $\mathbf{r} = \mathbf{a} + \lambda\mathbf{d}$.

- The equivalent parametric equation of line L is

$$\begin{aligned} x &= a_1 + \lambda d_1 \\ y &= a_2 + \lambda d_2 \\ z &= a_3 + \lambda d_3 \end{aligned}$$

- Reorganising the parametric set:

$$\frac{x - a_1}{d_1} = \frac{y - a_2}{d_2} = \frac{z - a_3}{d_3} = \lambda$$

This is referred to as the Cartesian equation of a line in 3D space.

Example 7.6

Find the parametric equation of the line passing through the points with position vectors $\langle 1, -1 \rangle$ and $\langle 4, 3 \rangle$. Hence find the Cartesian equation of this line.

Solution:

Direction vector of line, $\mathbf{d} = \langle 4, 3 \rangle - \langle 1, -1 \rangle = \langle 3, 4 \rangle$.

Hence, vector equation of line is $\mathbf{r} = \langle 1, -1 \rangle + \lambda \langle 3, 4 \rangle$.

Parametric equation of line is
$$\begin{aligned} x &= 1 + 3\lambda \\ y &= -1 + 4\lambda \end{aligned}$$

Cartesian equation of line is
$$\frac{x-1}{3} = \frac{y+1}{4}$$

 $\Rightarrow 4x - 3y = 7$

Example 7.7

Find the parametric equation of the line passing through the points with position vectors $\langle 2, 5, 10 \rangle$ and $\langle 3, 4, 12 \rangle$. Hence find the Cartesian equation of this line.

Solution:

Direction vector of line, $\mathbf{d} = \langle 3, 4, 12 \rangle - \langle 2, 5, 10 \rangle = \langle 1, -1, 2 \rangle$.

Hence, vector equation of line is $\mathbf{r} = \langle 2, 5, 10 \rangle + \lambda \langle 1, -1, 2 \rangle$.

Parametric equation of line is
$$\begin{aligned} x &= 2 + \lambda \\ y &= 5 - \lambda \\ z &= 10 + 2\lambda \end{aligned}$$

Cartesian equation of line is
$$x - 2 = 5 - y = \frac{z - 10}{2}$$

Example 7.8

Find the vector equation of the line with Cartesian equation $\frac{x}{3} = y + 2 = \frac{4 - z}{2}$

Solution:

Parametric equation of line is: $x = 3\lambda, y = -2 + \lambda, z = 4 - 2\lambda$.

Hence, vector equation of line is
$$\begin{pmatrix} x \\ y \\ z \end{pmatrix} = \begin{pmatrix} 0 \\ -2 \\ 4 \end{pmatrix} + \lambda \begin{pmatrix} 3 \\ 1 \\ -2 \end{pmatrix} \Rightarrow \mathbf{r} = \begin{pmatrix} 0 \\ -2 \\ 4 \end{pmatrix} + \lambda \begin{pmatrix} 3 \\ 1 \\ -2 \end{pmatrix}$$

Exercise 7.1

1. Find the vector equation of the line passing through the point with position vector \mathbf{a} and parallel to vector \mathbf{d} :

(a) $\mathbf{a} = 2\mathbf{i} + \mathbf{j}, \mathbf{d} = 4\mathbf{i} + 5\mathbf{j} - \mathbf{k}$

(b) $\mathbf{a} = 5\mathbf{k}, \mathbf{d} = 2\mathbf{j} - \mathbf{k}$

(c) $\mathbf{a} = \langle 1, 1, -1 \rangle, \mathbf{d} = \langle 1, 2, -1 \rangle$

(d) $\mathbf{a} = \langle \sqrt{2}, 0, 1 \rangle, \mathbf{d} = \langle 0, -1, \frac{1}{5} \rangle$

2. Find the vector equation of the line passing through the points with position vectors \mathbf{a} and \mathbf{b} :

(a) $\mathbf{a} = -2\mathbf{j}, \mathbf{b} = 2\mathbf{k}$

(b) $\mathbf{a} = \mathbf{i} + 2\mathbf{j} + \mathbf{k}, \mathbf{b} = 3\mathbf{i} + 5\mathbf{j} - 2\mathbf{k}$

(c) $\mathbf{a} = \begin{pmatrix} 1 \\ 2 \\ 5 \end{pmatrix}, \mathbf{b} = \begin{pmatrix} -2 \\ 1 \\ 7 \end{pmatrix}$

(d) $\mathbf{a} = \begin{pmatrix} 0.5 \\ -0.1 \\ 0.4 \end{pmatrix}, \mathbf{b} = \begin{pmatrix} 0.4 \\ -0.5 \\ 0.1 \end{pmatrix}$

3. Determine the value of λ if the point with position vector $\langle 5, 8, 7 \rangle$ lies in the line:

(a) $\mathbf{r} = \langle 1, 2, -3 \rangle + \lambda \langle 2, 3, 5 \rangle$

(b) $\mathbf{r} = \langle 15, 13, -23 \rangle + \lambda \langle 2, 1, -6 \rangle$

4. The point with position vector $\langle m, -9, -10 \rangle$ lie on the line $\mathbf{r} = \langle 12, 3, 4 \rangle + \lambda \langle 4, 6, 7 \rangle$. Find m .

5. The point with position vector $10\mathbf{i} + 8\mathbf{j} + 19\mathbf{k}$ lie on the line $\mathbf{r} = -2\mathbf{i} + m\mathbf{j} + 3\mathbf{k} + \lambda(3\mathbf{i} + \mathbf{j} + 4\mathbf{k})$. Find m .

6. Determine which of the points $\langle 9, 1, 8 \rangle, \langle -7, -3, -4 \rangle, \langle 13, -2, 11 \rangle$ lie on the line $\mathbf{r} = \langle 1, -1, 2 \rangle + \lambda \langle 4, 1, 3 \rangle$.

7. Find the vector equation of the line with equation:

(a) $y = -2x + 3$

(b) $y = \frac{4x}{3} - 1$

(c) $3x + 4y = 12$

8. A line has vector equation $\mathbf{r} = \langle 1, 3 \rangle + \lambda \langle -1, 3 \rangle$. Find the gradient of this line. Hence, or otherwise find the equation of this line in the form $y = mx + c$.

9. A line has vector equation $\mathbf{r} = \langle \lambda + 3, 1 - 2\lambda \rangle$. Find the parametric equation of this line. Hence, or otherwise find the equation of this line in the form $ax + by = c$.

10. Find the vector equation of the line passing through the point with position vector \mathbf{a} and parallel to the given line:

(a) $\mathbf{a} = -\mathbf{i} + 2\mathbf{j}, \mathbf{r} = (2\mathbf{i} + \mathbf{j} - \mathbf{k}) + \lambda(\mathbf{i} - 3\mathbf{j})$

(b) $\mathbf{a} = \langle 1, 2, 4 \rangle, \mathbf{r} = \langle (1 + 2\lambda), (2 - \lambda), (-\lambda) \rangle$

(c) $\mathbf{a} = \begin{pmatrix} 1 \\ -4 \\ 5 \end{pmatrix}, \mathbf{r} = \begin{pmatrix} 1 + \lambda \\ \lambda - 5 \\ 3\lambda - 4 \end{pmatrix}$

(d) $\mathbf{a} = \begin{pmatrix} 0 \\ 2 \\ 10 \end{pmatrix}, \mathbf{r} = \begin{pmatrix} 2 + 3\lambda \\ \frac{\lambda - 1}{2} \\ \frac{2\lambda - 5}{4} \end{pmatrix}$

11. Find the Cartesian equation of the line with vector equation:

(a) $\mathbf{r} = (5\mathbf{i} - 2\mathbf{j} - \mathbf{k}) + \lambda(2\mathbf{i} - 3\mathbf{j} + 5\mathbf{k})$ (b) $\mathbf{r} = \langle -1 - 2\lambda, (5 + \lambda), (3 - 4\lambda) \rangle$
 (c) $\mathbf{r} = \left\langle \frac{3+2\lambda}{4}, \frac{-2-2\lambda}{3}, \frac{5\lambda}{4} \right\rangle$ (d) $\mathbf{r} = \langle 1, -1, -1 \rangle + \lambda \left\langle \frac{2}{3}, \frac{-1}{5}, \frac{3}{5} \right\rangle$

12. Find the Cartesian equation of the line passing through the point with position vector \mathbf{a} and parallel to the given line:

(a) $\mathbf{a} = -\mathbf{i} - 2\mathbf{j} + 2\mathbf{k}$, $\mathbf{r} = (-2\mathbf{i} + 3\mathbf{j} + 5\mathbf{k}) + \lambda(\mathbf{i} - 3\mathbf{j} + 6\mathbf{k})$
 (b) $\mathbf{a} = \langle -1, -5, 6 \rangle$, $\mathbf{r} = \langle (4 - 2\lambda), (2 + 5\lambda), (-5 - 2\lambda) \rangle$

13. Find the Cartesian equation of the line passing through the points with position vectors

(a) $\langle 0, 0, 0 \rangle$ and $\langle 5, 5, 5 \rangle$ (b) $\langle -1, 3, 4 \rangle$ and $\langle 5, 6, -4 \rangle$
 (c) $\langle 3, 4, -1 \rangle$ and $\langle 2, 4, 1 \rangle$ (d) $\langle 10, 5, -5 \rangle$ and $\langle 10, 6, -5 \rangle$

14. Find the vector equation of the line with Cartesian equation:

(a) $x = \frac{y-2}{5} = \frac{3-z}{2}$ (b) $x = 0, -1 - y = \frac{z-5}{3}$
 (c) $\frac{1+2x}{3} = \frac{-1-2y}{4} = \frac{5+3z}{5}$ (d) $\frac{-1+4x}{5} = \frac{1-3y}{6} = \frac{2+6z}{-3}$

15. Find a vector that is perpendicular to $\langle 2, 5, -1 \rangle$. Hence, find the vector equation of a line passing through the point with position vector $\langle 1, 2, 3 \rangle$ and perpendicular to $\langle 2, 5, -1 \rangle$.

16. Find the vector equation of a line passing through the point with position vector $\langle 2, 2, -2 \rangle$ and perpendicular to the line $\mathbf{r} = \langle -1 - 2\lambda, 3 - \lambda, \frac{1+4\lambda}{-5} \rangle$.

17. A line has vector equation $\mathbf{r} = \langle a, b, c \rangle + \lambda \langle u, v, w \rangle$. Find:

(a) the parametric equation of this line (b) the Cartesian equation of this line.

18. Use a vector method to find the position vector of the point of intersection (where it exists) between the lines:

(a) $\mathbf{r} = \langle 1, 2, 1 \rangle + \lambda \langle 4, 5, 1 \rangle$ and $\mathbf{r} = \langle 5, 1, 2 \rangle + \mu \langle 4, 8, 1 \rangle$
 (b) $\mathbf{r} = \langle -1, 3, -2 \rangle + \lambda \langle 1, 10, 5 \rangle$ and $\mathbf{r} = \langle 3, 4, 26 \rangle + \lambda \langle 1, -10, 9 \rangle$

*19. Find the value(s) of m given that the lines with vector equations $\mathbf{r} = \langle 1, 2, -1 \rangle + \lambda \langle 1, -1, 4 \rangle$ and $\mathbf{r} = \langle 5, 1, 4 \rangle + \mu \langle 1, 2, m \rangle$ are non-intersecting.

*20. Find the algebraic relationship between m and n if the line with vector equation $\mathbf{r} = \langle m, -1, 1 \rangle + \lambda \langle 2, -1, 3 \rangle$ intersects the line with vector equation $\mathbf{r} = \langle -3, -1, -1 \rangle + \mu \langle 6, -2, n \rangle$.

21. Find the acute angle between the lines with vector equations:

(a) $\mathbf{r} = \langle 0, 0, 0 \rangle + \lambda \langle 0, 1, 0 \rangle$ and $\mathbf{r} = \langle 1, 1, 1 \rangle + \lambda \langle 1, 0, 0 \rangle$
 (b) $\mathbf{r} = \langle 0, -1, 1 \rangle + \lambda \langle 1, 2, -1 \rangle$ and $\mathbf{r} = \langle 1, 1, 0 \rangle + \lambda \langle 2, -2, 1 \rangle$.

*22. Find the equation of a line passing through $\langle 1, 2, 1 \rangle$ that is perpendicular to both $\mathbf{r} = \langle \lambda, (-1 - 2\lambda), (1 + 2\lambda) \rangle$ and $\mathbf{r} = \langle -2\lambda, (2 + \lambda), (5 + 2\lambda) \rangle$.

7.2 Scalar Product Equation of a Line in 2D

- Consider Line L which passes through the point A with position vector \mathbf{a} . Let Line L be perpendicular to vector \mathbf{n} .
- Let R with position vector \mathbf{r} be any point on Line L.
- Clearly, \mathbf{AR} is also perpendicular to \mathbf{n} .
- Hence, $\mathbf{AR} \cdot \mathbf{n} = 0$.

$$\text{But } \mathbf{AR} = \mathbf{r} - \mathbf{a} \Rightarrow (\mathbf{r} - \mathbf{a}) \cdot \mathbf{n} = 0$$

$$\mathbf{r} \cdot \mathbf{n} = \mathbf{a} \cdot \mathbf{n}$$

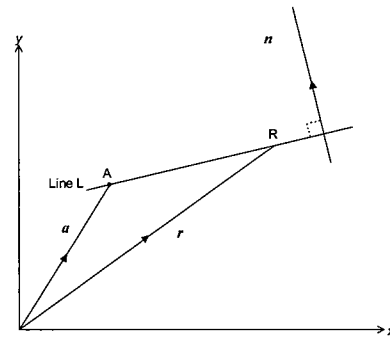

- In summary, in 2-dimensions, the scalar product (dot product) equation of a line passing through the point with position vector \mathbf{a} and perpendicular (normal) to the vector \mathbf{n} is:

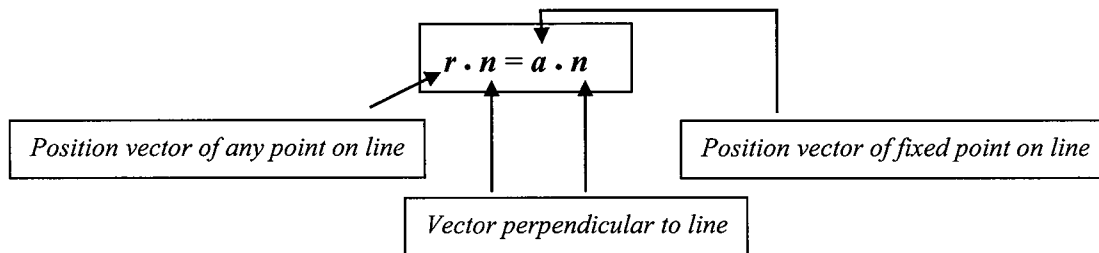

Example 7.9

Find a scalar product equation of the line passing through the point with position vector $5\mathbf{i} + 6\mathbf{j}$ and perpendicular to the vector $\mathbf{i} + 2\mathbf{j}$.

Solution:

$$\text{Scalar product equation of line is } \mathbf{r} \cdot (\mathbf{i} + 2\mathbf{j}) = (5\mathbf{i} + 6\mathbf{j}) \cdot (\mathbf{i} + 2\mathbf{j}) \Rightarrow \mathbf{r} \cdot (\mathbf{i} + 2\mathbf{j}) = 17.$$

Example 7.10

Find a vector equation of the line with scalar product equation $\mathbf{r} \cdot (4\mathbf{i} - 5\mathbf{j}) = 20$.

Solution:

$$\text{Let } \langle 0, k \rangle \text{ be a point on this line. } \Rightarrow \langle 0, k \rangle \cdot \langle 4, -5 \rangle = 20 \Rightarrow k = -4.$$

Hence, $\langle 0, -4 \rangle$ is a point on this line.

The given line is perpendicular to $\langle 4, -5 \rangle$. Hence, the given line is parallel to $\langle 5, 4 \rangle$.

Therefore, a vector equation of this line is $\mathbf{r} = \langle 0, -4 \rangle + \lambda \langle 5, 4 \rangle$.

Exercise 7.2

1. (a) Given that the point $\langle -1, 0 \rangle$ lies on the line $\mathbf{r} \cdot \langle 2, -3 \rangle = k$. Find k .
 (b) Given that the point $\langle 3, k \rangle$ lies on the line $\mathbf{r} \cdot \langle 0, 5 \rangle = 20$. Find k .
 (c) Given that the point $\langle 5, 4 \rangle$ lies on the line $\mathbf{r} \cdot \langle k, 6 \rangle = -10$. Find k .
 (d) Given that the point $\langle k, -7 \rangle$ lies on the line $\mathbf{r} \cdot \langle k, 3 \rangle = 4$. Find k .

2. Determine with reasons if the points:
 - (a) $\langle 2, -4 \rangle$ and $\langle 10, 9 \rangle$ lie on the line with equation $\mathbf{r} \cdot \langle 8, -7 \rangle = 8$
 - (b) $\langle -6, 12 \rangle$ and $\langle -3, 5 \rangle$ lie on the line with equation $\mathbf{r} \cdot \langle 11, 5 \rangle = -6$

3. Find a scalar product equation of the line passing through the point with position vector
 - (a) $-5\mathbf{i} + 3\mathbf{j}$ and perpendicular to the vector $2\mathbf{i} - 3\mathbf{j}$
 - (b) $2\mathbf{i} - 4\mathbf{j}$ and perpendicular to the vector $-5\mathbf{i} + 10\mathbf{j}$
 - (c) $-\mathbf{i} - 2\mathbf{j}$ and parallel to the vector $3\mathbf{i} - 10\mathbf{j}$
 - (d) $10\mathbf{i} - 2\mathbf{j}$ and parallel to the vector $4\mathbf{i} + 5\mathbf{j}$

4. Find a scalar product equation of the line passing through the point with position vector
 - (a) $2\mathbf{i} + 5\mathbf{j}$ and perpendicular to the line $\mathbf{r} = \mathbf{i} + 2\mathbf{j} + \lambda(6\mathbf{i} + \mathbf{j})$
 - (b) $-8\mathbf{i} + 3\mathbf{j}$ and perpendicular to the line $\mathbf{r} = \mathbf{i} + 2\mathbf{j} + \lambda(3\mathbf{i} - 4\mathbf{j})$
 - (c) $-12\mathbf{i} - 5\mathbf{j}$ and parallel to the line $\mathbf{r} = -\mathbf{i} + 4\mathbf{j} + \lambda(3\mathbf{i} + 8\mathbf{j})$
 - (d) $7\mathbf{i} - 9\mathbf{j}$ and parallel to the line $\mathbf{r} = -5\mathbf{i} - 2\mathbf{j} + \lambda(-2\mathbf{i} + 7\mathbf{j})$

5. Find a scalar product equation of the line passing through the point with position vector
 - (a) $8\mathbf{i} + 6\mathbf{j}$ and parallel to the line $\mathbf{r} \cdot (\mathbf{i} + 2\mathbf{j}) = 5$
 - (b) $0.5\mathbf{i} + 0.9\mathbf{j}$ and parallel to the line $\mathbf{r} \cdot (-4\mathbf{i} + 3\mathbf{j}) = 12$
 - (c) $15\mathbf{i} - 20\mathbf{j}$ and perpendicular to the line $\mathbf{r} \cdot (10\mathbf{i} - 3\mathbf{j}) = -30$
 - (d) $-2.5\mathbf{i} - 5.6\mathbf{j}$ and perpendicular to the line $\mathbf{r} \cdot (0.8\mathbf{i} + 2.7\mathbf{j}) = 5$

6. Find a vector equation $\mathbf{r} = \mathbf{a} + \lambda\mathbf{d}$ of the line with scalar product equation:
 - (a) $\mathbf{r} \cdot (\mathbf{i} - 2\mathbf{j}) = 12$
 - (b) $\mathbf{r} \cdot (5\mathbf{i} + 8\mathbf{j}) = -10$
 - (c) $\mathbf{r} \cdot (-\sqrt{3}\mathbf{i} + 4\mathbf{j}) = 5\sqrt{3}$

7. Find the position vector of the point of intersection (where possible) between the lines:
 - (a) $\mathbf{r} = \langle 1, 1 \rangle + \lambda\langle 3, 0 \rangle$ and $\mathbf{r} \cdot \langle 0, 5 \rangle = 3$
 - (b) $\mathbf{r} = \langle 3, 0 \rangle + \lambda\langle 4, -1 \rangle$ and $\mathbf{r} \cdot \langle 1, 4 \rangle = 10$
 - (c) $\mathbf{r} = \langle 0, 8 \rangle + \lambda\langle -5, 1 \rangle$ and $\mathbf{r} \cdot \langle -5, 1 \rangle = -18$
 - (d) $\mathbf{r} = \langle 7, 9 \rangle + \lambda\langle 1, 1 \rangle$ and $\mathbf{r} \cdot \langle -3, -1 \rangle = 6$.

8. Find the acute angle between the lines with equations:
 - (a) $\mathbf{r} \cdot \langle 0, 1 \rangle = 3$ and $\mathbf{r} \cdot \langle 0, -2 \rangle = 5$
 - (b) $\mathbf{r} \cdot \langle 2, -1 \rangle = 5$ and $\mathbf{r} \cdot \langle -1, 3 \rangle = 4$

9. Use scalar products to prove that the following lines are perpendicular:
 - (a) $\mathbf{r} = \langle 1, 0 \rangle + \lambda\langle 1, 1 \rangle$, $\mathbf{r} = \langle 0, 1 \rangle + \lambda\langle 1, -1 \rangle$
 - (b) $\mathbf{r} = \langle 5, 9 \rangle + \lambda\langle 8, 7 \rangle$, $\mathbf{r} = \langle 2, 1 \rangle + \lambda\langle -7, -8 \rangle$
 - (c) $\mathbf{r} \cdot \langle 10, 15 \rangle = 5$, $\mathbf{r} \cdot \langle 15, -10 \rangle = 6$
 - (d) $\mathbf{r} \cdot \langle -1, -3 \rangle = 5$, $\mathbf{r} \cdot \langle 3, -1 \rangle = -9$
 - (e) $\mathbf{r} \cdot \langle 3, 1 \rangle = 5$, $\mathbf{r} = \langle 0, 2 \rangle + \lambda\langle 3, 1 \rangle$
 - (f) $\mathbf{r} \cdot \langle 2, -1 \rangle = 5$, $\mathbf{r} = \langle 3, 4 \rangle + \lambda\langle 2, -1 \rangle$

7.3 Vector Equation of a Plane

- Consider the plane Π which passes through the fixed point A with position vector \mathbf{a} . Let vector \mathbf{n} be perpendicular to the plane Π .
- Let point R with position vector \mathbf{r} be any point on the plane Π . Note that the points A and R form a line L on the plane Π .
- Clearly, \mathbf{AR} which is within the plane Π is also perpendicular to \mathbf{n} .
- Hence, $\mathbf{AR} \cdot \mathbf{n} = 0$.
But $\mathbf{AR} = \mathbf{r} - \mathbf{a} \Rightarrow (\mathbf{r} - \mathbf{a}) \cdot \mathbf{n} = 0$

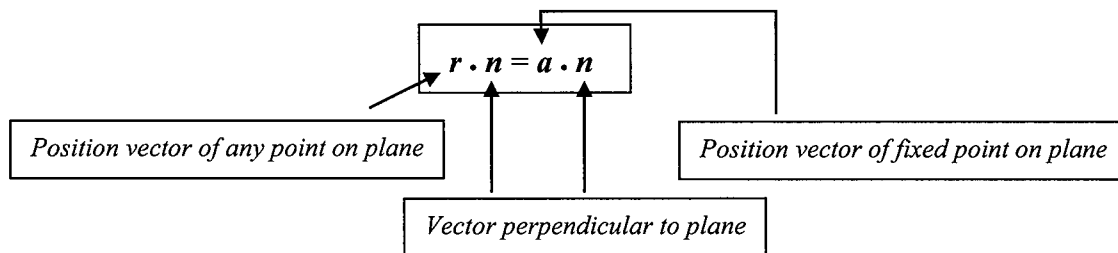
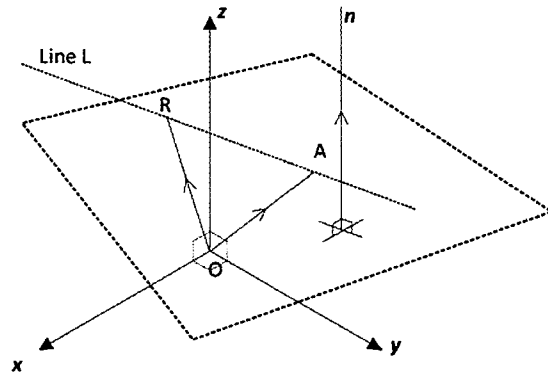

- The vector equation $\mathbf{r} \cdot \mathbf{n} = \mathbf{a} \cdot \mathbf{n}$ is ambiguous and must be read in context.
- In a 2D context, it represents the scalar product vector equation of a line passing through the fixed point with position vector \mathbf{a} and perpendicular to vector \mathbf{n} .
- However, in a 3D context, it represents the vector equation of a plane passing through the fixed point with position vector \mathbf{a} and perpendicular to vector \mathbf{n} .
- In each case, \mathbf{n} is termed the *normal* vector.
- Rewriting $\mathbf{r} = \langle x, y, z \rangle$ and $\mathbf{n} = \langle a, b, c \rangle$, $\mathbf{r} \cdot \mathbf{n} = \mathbf{a} \cdot \mathbf{n}$ becomes $\langle x, y, z \rangle \cdot \langle a, b, c \rangle = d$ where $\mathbf{a} \cdot \mathbf{n} = d$.
That is: $ax + by + cz = d$ which is the Cartesian equation of a plane.
 - Note that the coefficients of x , y and z are the components of the vector normal to the plane.
- For the plane with equation $\mathbf{r} \cdot \mathbf{n} = \rho$, $\frac{\rho}{|\hat{\mathbf{n}}|}$ represents the shortest distance from the origin to the plane. Hence, for the plane with equation $\mathbf{r} \cdot \hat{\mathbf{n}} = \gamma$, $|\gamma|$ represents the shortest distance from the origin to the plane.

Example 7.11

Given that the point $\langle 1, 1, 5 \rangle$ lies on the plane $\mathbf{r} \cdot \langle 3, 1, -4 \rangle = k$. Find k .

Solution:

Substitute $\langle 1, 1, 5 \rangle$ into the equation of the plane, $\langle 1, 1, 5 \rangle \cdot \langle 3, 1, -4 \rangle = k$.
 $3 + 1 - 20 = k \Rightarrow k = -16$.

Example 7.12

Determine if the points with position vectors $\langle 1, 1, 4 \rangle$ and $\langle 5, -1, 8 \rangle$ lie on the plane with equation $\mathbf{r} \cdot \langle -1, 3, 2 \rangle = 10$.

Solution:

Substitute $\langle 1, 1, 4 \rangle$ into LHS of equation of line. $\Rightarrow \langle 1, 1, 4 \rangle \cdot \langle -1, 3, 2 \rangle = 10$.
Hence, $\langle -1, 3, 2 \rangle$ lies on the plane.

$\langle 5, -1, 8 \rangle \cdot \langle -1, 3, 2 \rangle = 8 \neq 10$. Hence, $\langle 5, -1, 8 \rangle$ does not lie on the plane.

Example 7.13

Find the vector equation of the plane passing through the point with position vector $-2\mathbf{i} + 3\mathbf{j} + \mathbf{k}$ and perpendicular to the vector $-3\mathbf{i} + 2\mathbf{k}$.

Solution:

Vector equation of plane is $\mathbf{r} \cdot (-2\mathbf{i} + 3\mathbf{j} + \mathbf{k}) = (-2\mathbf{i} + 3\mathbf{j} + \mathbf{k}) \cdot (-3\mathbf{i} + 2\mathbf{k})$
 $\Rightarrow \mathbf{r} \cdot (-2\mathbf{i} + 3\mathbf{j} + \mathbf{k}) = 8$

Example 7.14

Find the vector equation of the plane perpendicular to the vector $\langle 2, -2, 5 \rangle$ and containing the line with equation $\mathbf{r} = \langle 1 - \lambda, 3 + 4\lambda, -1 + 2\lambda \rangle$.

Solution:

Line is perpendicular to $\langle 2, -2, 5 \rangle$ as the line lies on the given plane.

Let $\lambda = 0$.

Hence, the point with position vector $\langle 1, 3, -1 \rangle$ lies on the given line and hence lies on the given plane.

Therefore, vector equation of plane is $\mathbf{r} \cdot \langle 1, 3, -1 \rangle = \langle 1, 3, -1 \rangle \cdot \langle 2, -2, 5 \rangle$
 $\mathbf{r} \cdot \langle 1, 3, -1 \rangle = -9$

Example 7.15

Find the position vector of the point of intersection between the line $\mathbf{r} = \langle 2\lambda, 1 + \lambda, 3 - \lambda \rangle$ and the plane $\mathbf{r} \cdot \langle -1, 1, 4 \rangle = 3$.

Solution:

Substitute $\mathbf{r} = \langle 2\lambda, 1 + \lambda, 3 - \lambda \rangle$ into $\mathbf{r} \cdot \langle -1, 1, 4 \rangle = 3$.

$$\langle 2\lambda, 1 + \lambda, 3 - \lambda \rangle \cdot \langle -1, 1, 4 \rangle = 3$$

$$\Rightarrow -5\lambda + 13 = 3 \Rightarrow \lambda = 2$$

Hence, point of intersection has position vector $\langle 4, 3, 1 \rangle$.

Example 7.16

A plane passes through the points A, B and C with position vectors $\langle 1, 2, 1 \rangle$, $\langle -2, -1, 4 \rangle$ and $\langle 2, 1, -2 \rangle$ respectively. Without the use of a calculator, find the vector equation of the plane in the form $\mathbf{r} \cdot \mathbf{n} = k$.

Solution:

$$\mathbf{AB} = \langle -2, -1, 4 \rangle - \langle 1, 2, 1 \rangle = \langle -3, -3, 3 \rangle$$

$$\mathbf{AC} = \langle 2, 1, -2 \rangle - \langle 1, 2, 1 \rangle = \langle 1, -1, -3 \rangle$$

Let \mathbf{n} be a vector normal to the plane containing the points A, B and C.

Clearly $\mathbf{AB} \times \mathbf{AC}$ will be normal to the plane.

Hence, $\mathbf{n} = \mathbf{AB} \times \mathbf{AC}$

$$= \left\langle \begin{vmatrix} -3 & 3 \\ -1 & -3 \end{vmatrix}, -\begin{vmatrix} -3 & 3 \\ 1 & -3 \end{vmatrix}, \begin{vmatrix} -3 & -3 \\ 1 & -1 \end{vmatrix} \right\rangle$$

$$= \langle 12, -6, 6 \rangle = 6 \langle 2, -1, 1 \rangle$$

Hence, vector equation of plane is $\mathbf{r} \cdot \langle 2, -1, 1 \rangle = \langle 1, 2, 1 \rangle \cdot \langle 2, -1, 1 \rangle$

$$\mathbf{r} \cdot \langle 2, -1, 1 \rangle = 1$$

Note:

- As $\langle 12, -6, 6 \rangle = 6 \langle 2, -1, 1 \rangle$, both $\langle 12, -6, 6 \rangle$ and $\langle 2, -1, 1 \rangle$ will be normal to the plane.

Example 7.17

Find the Cartesian equation of the plane with equation $\mathbf{r} \cdot \langle 2, -1, 4 \rangle = 10$.

Solution:

Let $\mathbf{r} = \langle x, y, z \rangle$.

Hence, $\langle x, y, z \rangle \cdot \langle 2, -1, 4 \rangle = 10$ becomes $2x - y + 4z = 10$.

The Cartesian equation of the plane is $2x - y + 4z = 10$.

Example 7.18

Find the vector equation of the plane with equation $x - 2y + 4z = 8$.

Solution:

Rewrite $x - 2y + 4z = 8$ as $\langle x, y, z \rangle \cdot \langle 1, -2, 4 \rangle = 8$.

Hence, vector equation of plane is $\mathbf{r} \cdot \langle 1, -2, 4 \rangle = 8$

7.3.1 Alternative form for the vector equation of a plane

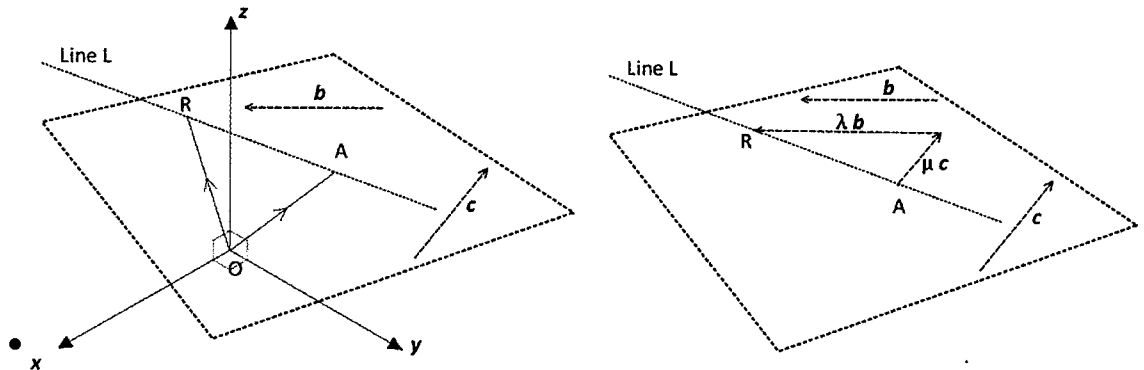

- Let the point A with position vector \mathbf{a} lie on the plane Π .
Let \mathbf{b} and \mathbf{c} be two non-parallel vectors that lie on the plane Π .
Let R with position vector \mathbf{r} be any point on the plane Π .
 - Clearly $\mathbf{OR} = \mathbf{OA} + \mathbf{AR}$
 $\mathbf{r} = \mathbf{a} + \mathbf{AR}$
 - Since \mathbf{AR} is on the same plane as the non-parallel vectors \mathbf{b} and \mathbf{c} , we can express \mathbf{AR} in terms of \mathbf{b} and \mathbf{c} .
 - Let $\mathbf{AR} = \lambda \mathbf{b} + \mu \mathbf{c}$.
 - Hence
$$\mathbf{r} = \mathbf{a} + \lambda \mathbf{b} + \mu \mathbf{c}$$
- Hence, the vector equation of a plane passing through the point with position vector \mathbf{a} and containing the non-parallel vectors \mathbf{b} and \mathbf{c} is $\mathbf{r} = \mathbf{a} + \lambda \mathbf{b} + \mu \mathbf{c}$

Example 7.19

A plane passes through the points A, B and C with position vectors $\langle 1, 2, 1 \rangle$, $\langle -2, -1, 4 \rangle$ and $\langle 2, 1, -2 \rangle$ respectively. Find the vector equation of the plane.

Solution:

$$\mathbf{AB} = \langle -2, -1, 4 \rangle - \langle 1, 2, 1 \rangle = \langle -3, -3, 3 \rangle$$

$$\mathbf{AC} = \langle 2, 1, -2 \rangle - \langle 1, 2, 1 \rangle = \langle 1, -1, -3 \rangle$$

Hence, vector equation is $\mathbf{r} = \langle 1, 2, 1 \rangle + \lambda \langle -3, -3, 3 \rangle + \mu \langle 1, -1, -3 \rangle$.

Exercise 7.3

- Given that the point $\langle -1, 0, 5 \rangle$ lies on the plane $\mathbf{r} \cdot \langle 1, 4, -3 \rangle = k$. Find k .
 - Given that the point $\langle -2, 6, k \rangle$ lies on the plane $\mathbf{r} \cdot \langle 2, -2, 8 \rangle = -25$. Find k .
 - Given that the point $\langle 1, -2, -5 \rangle$ lies on the plane $\mathbf{r} \cdot \langle 3, k, -2 \rangle = 16$. Find k .
 - Given that the point $\langle 2, k, -10 \rangle$ lies on the plane $\mathbf{r} \cdot \langle 2, 5, k \rangle = 10$. Find k .
- Determine with reasons if the points:
 - $\langle 2, 2, -4 \rangle$ and $\langle 5, -4, 5 \rangle$ lie on the plane with equation $\mathbf{r} \cdot \langle 1, 4, -2 \rangle = 18$
 - $\langle 5, 9, -11 \rangle$ and $\langle 3, 5, 6 \rangle$ lie on the plane with equation $\mathbf{r} \cdot \langle 1, 4, 5 \rangle = -6$
- Find the vector equation of the plane passing through the point with position vector
 - $-\mathbf{i} + 2\mathbf{j} + 3\mathbf{k}$ and perpendicular to the vector $4\mathbf{i} + 3\mathbf{k}$
 - $2\mathbf{i} - 4\mathbf{j} + 6\mathbf{k}$ and perpendicular to the vector $-3\mathbf{i} + 7\mathbf{j} + 10\mathbf{k}$
 - $\langle 4, 8, -3 \rangle$ and perpendicular to the vector $\langle 1, 4, 1 \rangle$
 - $\begin{pmatrix} 2 \\ -5 \\ 8 \end{pmatrix}$ and perpendicular to the vector $\begin{pmatrix} 4 \\ 8 \\ -11 \end{pmatrix}$.
- Find the vector equation of the plane perpendicular to the vector \mathbf{n} and containing the line with the given equation:
 - $\mathbf{n} = -\mathbf{i} + 2\mathbf{k}$, $\mathbf{r} = \mathbf{i} + 4\mathbf{j} - 5\mathbf{k} + \lambda(8\mathbf{i} + \mathbf{j} + 4\mathbf{k})$
 - $\mathbf{n} = \langle 3, -2, -2 \rangle$, $\mathbf{r} = \langle 3, -2, -5 \rangle + \lambda \langle -2, -8, 5 \rangle$
 - $\mathbf{n} = \langle -4, 7, 9 \rangle$, $\mathbf{r} = \langle 3 + \lambda, -2 - 2\lambda, 1 + 2\lambda \rangle$
 - $\mathbf{n} = \langle 1, 10, -10 \rangle$, $\mathbf{r} = \langle \frac{1+12\lambda}{4}, \frac{-1+\lambda}{2}, \frac{1+4\lambda}{5} \rangle$
- Find the position vector of the point of intersection between the given line and plane:
 - $\mathbf{r} = -3\mathbf{i} - 2\mathbf{j} + 4\mathbf{k} + \lambda(\mathbf{i} + 2\mathbf{j} - 4\mathbf{k})$; $\mathbf{r} \cdot \langle 3, 1, -4 \rangle = 36$
 - $\mathbf{r} = \langle 2 + 3\lambda, 1 + 5\lambda, 11 - 6\lambda \rangle$; $\mathbf{r} \cdot \langle 7, -6, 5 \rangle = -15$
 - $\frac{1-x}{2} = \frac{y-3}{5} = z+8$; $\mathbf{r} \cdot \langle 10, 15, -4 \rangle = 138$
 - $\mathbf{r} = \langle \frac{-3\lambda}{4}, \frac{5+2\lambda}{5}, \frac{-1-2\lambda}{4} \rangle$; $\mathbf{r} \cdot \langle 3, 7, -4 \rangle = \frac{67}{2}$
- Find the vector equation of the plane in the form (i) $\mathbf{r} \cdot \mathbf{n} = k$ (ii) $\mathbf{r} = \mathbf{a} + \lambda \mathbf{b} + \mu \mathbf{c}$ passing through the points with position vectors:
 - $\langle 0, 0, 0 \rangle$, $\langle 0, 1, 0 \rangle$, $\langle 0, 0, 1 \rangle$
 - $\langle 1, 2, 5 \rangle$, $\langle 5, 2, 1 \rangle$, $\langle 2, 1, 5 \rangle$
 - $\langle -2, 3, 4 \rangle$, $\langle -7, -4, 2 \rangle$, $\langle 6, 3, -4 \rangle$
 - $\langle 4, 10, 8 \rangle$, $\langle 6, 8, -5 \rangle$, $\langle 3, 5, 9 \rangle$
- Find the vector equation of the plane in the form $\mathbf{r} \cdot \mathbf{n} = k$ passing through the point with position vector \mathbf{a} and the given line:
 - $\mathbf{a} = -\mathbf{i} + \mathbf{j} + \mathbf{k}$, $\mathbf{r} = 2\mathbf{i} - 3\mathbf{j} + 5\mathbf{k} + \lambda(\mathbf{i} - \mathbf{j} + 2\mathbf{k})$
 - $\mathbf{a} = \langle 1, 4, 7 \rangle$, $\mathbf{r} = \langle 2, 2, 2 \rangle + \lambda \langle 6, 1, 8 \rangle$.
- Find the vector equation of the plane in the form $\mathbf{r} \cdot \mathbf{n} = k$ passing through the lines with equation:
 - $\mathbf{r} = \mathbf{i} - \mathbf{j} + \mathbf{k} + \lambda(\mathbf{i} - \mathbf{j} + 2\mathbf{k})$ and $\mathbf{r} = -\mathbf{i} + 2\mathbf{j} - 5\mathbf{k} + \lambda(3\mathbf{i} + \mathbf{j} - 2\mathbf{k})$
 - $\mathbf{r} = \langle 1, 2, 3 \rangle + \lambda \langle 2, 7, 1 \rangle$ and $\mathbf{r} = \langle 4 - \lambda, 2 + 7\lambda, 7 - 3\lambda \rangle$

9. Find the vector equation of a plane passing through the point with position vector \mathbf{a} and parallel to the given plane.
 (a) $\mathbf{a} = \langle 1, 2, -5 \rangle$; $\mathbf{r} \cdot \langle 2, 8, 9 \rangle = 30$ (b) $\mathbf{a} = \langle 2, 5, 8 \rangle$; $\mathbf{r} \cdot \langle -6, 3, 1 \rangle = -10$
10. Find the vector equation of a plane passing through the point with position vector \mathbf{a} and perpendicular to the given plane.
 (a) $\mathbf{a} = \langle 4, -5, 3 \rangle$; $\mathbf{r} \cdot \langle -1, 0, 6 \rangle = 5$ (b) $\mathbf{a} = \langle -3, 7, 5 \rangle$; $\mathbf{r} \cdot \langle 1, 2, -3 \rangle = 20$
11. Find the Cartesian equation of the plane with vector equation:
 (a) $\mathbf{r} \cdot \langle 0, 0, 3 \rangle = 5$ (b) $\mathbf{r} \cdot \langle 0, -2, 0 \rangle = 5$
 (c) $\mathbf{r} \cdot \langle -2, -4, 3 \rangle = 10$ (d) $\mathbf{r} \cdot \langle 5, 2, -6 \rangle = 25$
12. Find the vector equation of the plane with Cartesian equation:
 (a) $x = 5$ (b) $x + y = 1$
 (c) $y + z = 6$ (d) $2x - 3y + 4z = 8$
- *13. Find the point of intersection between the planes $\mathbf{r} \cdot \langle 1, -4, 1 \rangle = 10$,
 $\mathbf{r} \cdot \langle -1, 2, -1 \rangle = -4$ and $\mathbf{r} \cdot \langle 2, 4, 1 \rangle = 5$

7.3.2 Angle between line and plane

- A is a point on the line L with equation $\mathbf{r} = \mathbf{a} + \lambda \mathbf{d}$. The line L intersects the plane with equation $\mathbf{r} \cdot \mathbf{n} = \rho$ at B. K is the foot of the perpendicular from the point A to the plane.
- The angle between the line L and the plane is $\angle ABK = \alpha$.
- Let $\angle BAK = \theta$. Clearly, θ is the angle between \mathbf{d} , the direction vector of the line L, and the normal vector \mathbf{n} .

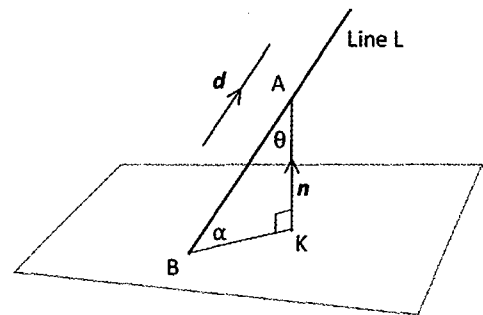

- Hence, $\cos \theta = \frac{\mathbf{d} \cdot \mathbf{n}}{|\mathbf{d}| |\mathbf{n}|} = \hat{\mathbf{d}} \cdot \hat{\mathbf{n}}$
 $\Rightarrow \theta = \cos^{-1}(\hat{\mathbf{d}} \cdot \hat{\mathbf{n}})$

- But $\alpha = 90^\circ - \theta$.
 Hence, the angle between $\mathbf{r} = \mathbf{a} + \lambda \mathbf{d}$ and $\mathbf{r} \cdot \mathbf{n} = \rho$ is $90^\circ - \theta = 90^\circ - \cos^{-1}(\hat{\mathbf{d}} \cdot \hat{\mathbf{n}})$.
- Alternatively, $\sin \alpha = \cos \theta \Rightarrow \sin \alpha = \hat{\mathbf{d}} \cdot \hat{\mathbf{n}}$.
 Hence, the angle between $\mathbf{r} = \mathbf{a} + \lambda \mathbf{d}$ and $\mathbf{r} \cdot \mathbf{n} = \rho$ is $\sin^{-1}(\hat{\mathbf{d}} \cdot \hat{\mathbf{n}})$.

Example 7.20

Find the acute angle between the line $r = \langle 1 - 2\lambda, \lambda, 2 + 3\lambda \rangle$ and the plane $r \cdot \langle 3, 1, 2 \rangle = -4$.

Solution:

The line with equation $r = \langle 1 - 2\lambda, \lambda, 2 + 3\lambda \rangle$ has direction vector $d = \langle -2, 1, 3 \rangle$

The plane with equation $r \cdot \langle 3, 1, 2 \rangle = -4$ has normal vector $n = \langle 3, 1, 2 \rangle$.

The angle between d and n is given by:

$$\cos \theta = \frac{\langle -2, 1, 3 \rangle \cdot \langle 3, 1, 2 \rangle}{|\langle -2, 1, 3 \rangle| |\langle 3, 1, 2 \rangle|} = \frac{1}{14}$$

$$\Rightarrow \theta = 85.9^\circ$$

angle([-2,1,3],[3,1,2])
85.9040

Hence, the acute angle between the line and plane is $90 - 85.9 = 4.1^\circ$.

Alternatively:

$$\begin{aligned} \text{Angle between line and plane} &= \sin^{-1} \left(\frac{\langle -2, 1, 3 \rangle \cdot \langle 3, 1, 2 \rangle}{|\langle -2, 1, 3 \rangle| |\langle 3, 1, 2 \rangle|} \right) \\ &= \sin^{-1} \frac{1}{14} = 4.1^\circ. \end{aligned}$$

7.3.3 Angle between two planes

- The angle between two planes ABCD and CDEF is given by $\angle MKN$.
- MK and NK are lines respectively on each of the planes and are each perpendicular to the line of intersection between the two planes.
- Let the equations of the planes ABCD and CDEF be $r \cdot m = \rho_1$ and $r \cdot n = \rho_2$ respectively.
- Let $\angle MKN = \theta$. n is normal to KN and m is normal to KM. Quite clearly the angle between m and n is also θ .
- Hence, the angle between the planes $r \cdot m = \rho_1$ and $r \cdot n = \rho_2$ is the angle between the normal vectors of the two planes and is given by $\cos^{-1} (\hat{m} \cdot \hat{n})$.

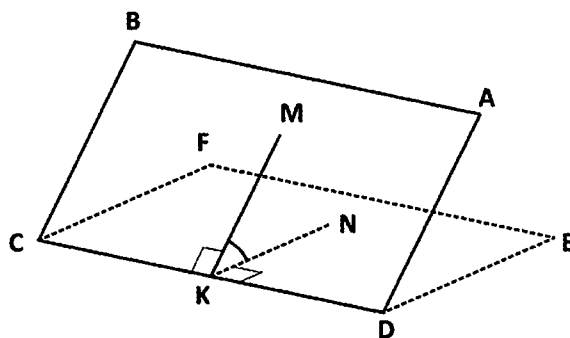

Example 7.21

Find the acute angle between the planes $\mathbf{r} \cdot \langle 1, 2, -2 \rangle = 5$ and $\mathbf{r} \cdot \langle -1, -1, 2 \rangle = -4$.

Solution:

The plane with equation $\mathbf{r} \cdot \langle 1, 2, -2 \rangle = 5$ is perpendicular to $\langle 1, 2, -2 \rangle$.

The plane with equation $\mathbf{r} \cdot \langle -1, -1, 2 \rangle = -4$ is perpendicular to $\langle -1, -1, 2 \rangle$.

Hence, the angle between the 2 planes = angle between the two normal vectors.

Angle between $\langle 1, 2, -2 \rangle$ and $\langle -1, -1, 2 \rangle$ is given by

$$\cos \theta = \frac{\langle 1, 2, -2 \rangle \cdot \langle -1, -1, 2 \rangle}{|\langle 1, 2, -2 \rangle| |\langle -1, -1, 2 \rangle|} = \frac{-7}{3\sqrt{6}}$$

$$\Rightarrow \theta = 162.3^\circ$$

Hence, acute angle between the two planes = $180 - 162.3 = 17.7^\circ$.

Exercise 7.4

1. Use vector methods to find the acute angle between the following lines and planes:

(a) $\mathbf{r} = \langle 1, 1, -4 \rangle + \lambda \langle 3, 0, 4 \rangle$; $\mathbf{r} \cdot \langle 0, 0, 1 \rangle = 5$

(b) $\mathbf{r} = \langle -1 + 2\lambda, 3\lambda, 1 - \lambda \rangle$; $\mathbf{r} \cdot \langle 0, 1, 1 \rangle = -4$

(c) $\mathbf{r} = \langle \frac{-\lambda}{4}, \frac{5-\lambda}{5}, \frac{-1+2\lambda}{3} \rangle$; $\mathbf{r} \cdot \langle 1, 3, 3 \rangle = 12$

(d) $x = 1 + \lambda, 2y = \lambda, 3z = 1 + \lambda; x + 4y - z = 1$

2. The line $\mathbf{r} = \langle 4 + 3\lambda, 1 - 3\lambda, 1 + \lambda \rangle$ is inclined at an angle of 60° to the plane $\mathbf{r} \cdot \langle a, -2, 1 \rangle = 4$. Find a .

3. The line $\mathbf{r} = \langle 4, 1, -3 \rangle + \lambda \langle 3, b, 2 \rangle$ is inclined at an angle of 45° to the plane $\mathbf{r} \cdot \langle 1, 4, 5 \rangle = 20$. Find b .

4. Find the vector equation of the line passing through the point with position vector $\langle 3, 2, -1 \rangle$ and perpendicular to the plane $\mathbf{r} \cdot \langle 5, 2, -8 \rangle = 16$.

5. Use vector methods to find the acute angle between the following planes:

(a) $\mathbf{r} \cdot \langle 0, 0, 1 \rangle = 5$; $\mathbf{r} \cdot \langle 0, 1, 0 \rangle = 2$ (b) $\mathbf{r} \cdot \langle 0, -1, 0 \rangle = 3$; $\mathbf{r} \cdot \langle 1, 0, 0 \rangle = 10$

(c) $\mathbf{r} \cdot \langle 1, 2, -1 \rangle = -3$; $\mathbf{r} \cdot \langle 3, -1, 4 \rangle = 13$

(d) $\mathbf{r} \cdot \langle 5, -4, 3 \rangle = 6$; $\mathbf{r} \cdot \langle -5, 2, 10 \rangle = 15$

6. The acute angle between the planes with equations $\mathbf{r} \cdot \langle a, 3, 5 \rangle = 10$ and $\mathbf{r} \cdot \langle -5, 1, 4 \rangle = 30$ is 45° . Find a .

7. The acute angle between the planes with equations $\mathbf{r} \cdot \langle 1, b, -2 \rangle = 10$ and $\mathbf{r} \cdot \langle 1, 2, 0 \rangle = 20$ is 30° . Find b .

8. Find the algebraic relationship between m and n if the plane $\mathbf{r} \cdot \langle -1, m, n \rangle = 12$ is inclined to the plane $\mathbf{r} \cdot \langle 1, 1, 0 \rangle = 15$ at an angle of 60° .
9. Find the acute angle between the planes $2x + 3y - 5z = 10$ and $-x + 2y + 4z = 4$.
10. Find the vector equation of the plane which passes through the point with position vector $\langle 2, 1, -2 \rangle$ and is perpendicular to the plane $\mathbf{r} \cdot \langle 3, 1, -2 \rangle = 6$.

7.4 Vector Equation of a Sphere

- Consider the point R with position vector \mathbf{r} on the surface of a sphere of radius k and centre A with position vector \mathbf{a} .
- Clearly, $\mathbf{AR} = \mathbf{OR} - \mathbf{OA}$.
 $\Rightarrow \mathbf{AR} = \mathbf{r} - \mathbf{a}$.
- $|\mathbf{AR}| =$ radius of the given sphere
 $\Rightarrow |\mathbf{AR}| = |\mathbf{r} - \mathbf{a}| = k$.
- That is, any point R, with position vector \mathbf{r} , on the surface of the sphere, satisfies the equation $|\mathbf{r} - \mathbf{a}| = k$.
- Hence, the vector equation of a sphere with radius k and centre with position vector \mathbf{a} is:

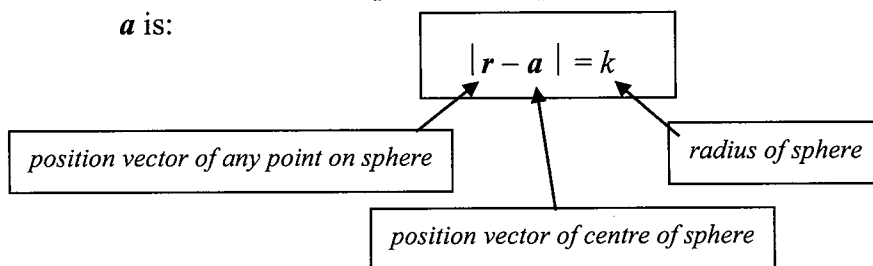
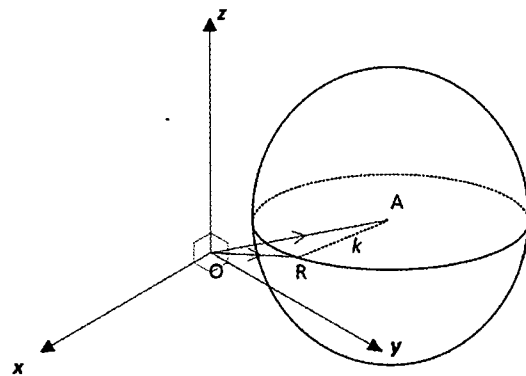

- Rewriting $\mathbf{r} = \langle x, y, z \rangle$ and $\mathbf{a} = \langle a_1, a_2, a_3 \rangle$ $|\mathbf{r} - \mathbf{a}| = k$ becomes $(x - a_1)^2 + (y - a_2)^2 + (z - a_3)^2 = k^2$ which is the Cartesian equation of a sphere of radius k with centre located at (a_1, a_2, a_3)
- Using a similar method, it may also be shown that the vector equation of a circle with radius k and centre with position vector \mathbf{a} is $|\mathbf{r} - \mathbf{a}| = k$.

Example 7.22

Find the vector equation of a sphere with centre at (3, 4, 2) and radius 1.

Solution:

Vector equation is $|\mathbf{r} - \langle 3, 4, 2 \rangle| = 1$.

Example 7.23

Find the vector equation of the sphere with Cartesian equation $x^2 + y^2 + z^2 - 2x + 4y = 11$.

Solution:

Rewrite equation: $x^2 - 2x + y^2 + 4y + z^2 = 11$

Completing squares: $(x - 1)^2 + (y + 2)^2 + z^2 = 11 + 1 + 4$

$(x - 1)^2 + (y + 2)^2 + z^2 = 16$

Hence, vector equation is $|\mathbf{r} - \langle 1, -2, 0 \rangle| = 4$.

Example 7.24

Use a vector method to determine if the point with position vector $\langle 1, 6, -1 \rangle$ is outside, on or inside the sphere with equation $|\mathbf{r} - \langle 3, 2, 2 \rangle| = 4$.

Solution:

$$\begin{aligned} \text{Distance from point to centre of circle} &= |\langle 1, 6, -1 \rangle - \langle 3, 2, 2 \rangle| = |\langle -2, 4, -3 \rangle| \\ &= \sqrt{(-2)^2 + 4^2 + (-3)^2} = \sqrt{29} \end{aligned}$$

Since this distance $>$ radius of sphere ($= 4$), the given point is outside the sphere.

Example 7.25

Use a vector method to find the position vector of the points of intersection (if any) between the line $\mathbf{r} = \langle -1, 1, 2 \rangle + \lambda \langle 1, 2, -1 \rangle$ and the sphere $|\mathbf{r} - \langle 1, 1, 1 \rangle| = \sqrt{5}$.

Solution:

Substitute $\mathbf{r} = \langle -1 + \lambda, 1 + 2\lambda, 2 - \lambda \rangle$ into $|\mathbf{r} - \langle 1, 1, 1 \rangle| = \sqrt{5}$.

$$\Rightarrow |\langle -1 + \lambda, 1 + 2\lambda, 2 - \lambda \rangle - \langle 1, 1, 1 \rangle| = \sqrt{5}$$

$$|\langle -2 + \lambda, 2\lambda, 1 - \lambda \rangle| = \sqrt{5}$$

$$(-2 + \lambda)^2 + (2\lambda)^2 + (1 - \lambda)^2 = 5$$

$$\lambda = 0, 1$$

Hence, required position vectors are: $\mathbf{r} = \langle -1, 1, 2 \rangle$ and $\langle 0, 3, 1 \rangle$.

$$\text{solve}((-2+x)^2+(2x)^2+(1-x)^2=5$$

$$\{x=0, x=1\}$$

Example 7.26

Prove that the line $\mathbf{r} = \langle 3, 0, 2 \rangle + \lambda \langle 2, 2, -1 \rangle$ is a tangent to the sphere $|\mathbf{r} - \langle 2, 1, -1 \rangle| = \sqrt{10}$.

Solution:

$$\begin{aligned} \text{Substitute } \mathbf{r} = \langle 3 + 2\lambda, 2\lambda, 2 - \lambda \rangle \text{ into } |\mathbf{r} - \langle 2, 1, -1 \rangle| &= \sqrt{10}. \\ \Rightarrow |\langle 3 + 2\lambda, 2\lambda, 2 - \lambda \rangle - \langle 2, 1, -1 \rangle| &= \sqrt{10} \\ (1 + 2\lambda)^2 + (2\lambda - 1)^2 + (3 - \lambda)^2 &= 10 \\ \Rightarrow \lambda &= \frac{1}{3}. \end{aligned}$$

Hence, there is only one point of contact.
 \Rightarrow The given line is a tangent to the sphere.

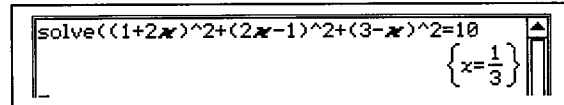

Exercise 7.5

- Find the vector and Cartesian equations of a sphere with the stated centre and radius.
 - centre $(3, 4, 0)$, radius = 3
 - centre $(-1, 2, 2)$, radius = 5
 - centre $(-1, 2, -5)$, radius = $\sqrt{10}$
 - centre $(1, 4, -5)$, radius = 4
- The point $(3, 2, 1)$ lies on the sphere with equation $|\mathbf{r} - \langle 5, 4, 1 \rangle| = k$. Find k .
- The points $(-3, -1, 1)$, $(1, -2, -2)$ and $(-3, 2, -2)$ lie on the sphere with equation $|\mathbf{r} - \mathbf{a}| = 5$. Find \mathbf{a} .
- Determine if the indicated points are outside, on or inside the stated spheres.
 - $(1, 5, -1)$, $|\mathbf{r} - \langle -1, -2, 1 \rangle| = 7$
 - $(-3, 2, -6)$, $|\mathbf{r} - \langle 2, -1, 5 \rangle| = 13$
- Find the vector equation of the following spheres:
 - $x^2 + y^2 + z^2 + 2x - 4y + 6z = 11$
 - $3x^2 + 3y^2 + 3z^2 - 3x - 9y + 6z = 2$
- Find the point(s) of intersection (if any) between the given line and sphere.
 - $\mathbf{r} = \langle 0, 4, 1 \rangle + \lambda \langle 1, 2, -1 \rangle$, $|\mathbf{r} - \langle 4, 0, 2 \rangle| = 7$
 - $\mathbf{r} = \langle 1, 1, 2 \rangle + \lambda \langle -1, 1, 1 \rangle$, $|\mathbf{r} - \langle 1, -1, 2 \rangle| = 6$
- Prove that the line $\mathbf{r} = \langle 1, 1, 2 \rangle + \lambda \langle -1, 0, 0 \rangle$ is a tangent to the sphere with equation $|\mathbf{r} - \langle -1, 0, 1 \rangle| = \sqrt{2}$.
- Prove that the line $\mathbf{r} = \langle 1, 0, 2 \rangle + \lambda \langle -2, 1, -2 \rangle$ is a tangent to the sphere with equation $|\mathbf{r} - \langle 0, -1, 1 \rangle| = \sqrt{2}$.
- Find the equation of a sphere passing through the points $(-1, 2, 2)$, $(1, -2, -2)$, $(-1, -1, 1)$ and $(1, 1, 1)$.
- Find the intersection (if any) between the given sphere and plane.
 - $|\mathbf{r}| = 10, x = 6$
 - $|\mathbf{r}| = 3, y = 5$
- Find intersection (if any) between the spheres:
 - $|\mathbf{r}| = 5, |\mathbf{r} - \langle 1, 0, 0 \rangle| = 5$
 - $|\mathbf{r} - \langle 1, 0, 1 \rangle| = 4, |\mathbf{r} - \langle 1, 0, 0 \rangle| = 5$

7.5 Shortest Distance

7.5.1 Shortest Distance between point and line

- It is required to find the shortest distance between a point B with position vector \mathbf{b} and the line L with equation $\mathbf{r} = \mathbf{a} + \lambda\mathbf{d}$.

- Scalar Product Method

- Let M be the foot of the perpendicular from B to the line L.
- Hence, the closest distance is $|\mathbf{BM}|$ where $\mathbf{BM} \cdot \mathbf{d} = 0$.

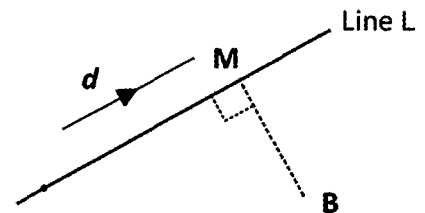

- Cross Product Method

- Let M be the foot of the perpendicular from B to the line L. Let A with position vector \mathbf{a} be any point on the line L. Let θ be the angle between \mathbf{AB} and the line L.

$$\begin{aligned} \text{Shortest distance} &= |\mathbf{BM}| \\ &= |\mathbf{AB}| \sin \theta \\ &= \frac{|\mathbf{d}| |\mathbf{b} - \mathbf{a}| \sin \theta}{|\mathbf{d}|} \\ &= \frac{|(\mathbf{b} - \mathbf{a}) \times \mathbf{d}|}{|\mathbf{d}|} \\ &= |(\mathbf{b} - \mathbf{a}) \times \hat{\mathbf{d}}| \end{aligned}$$

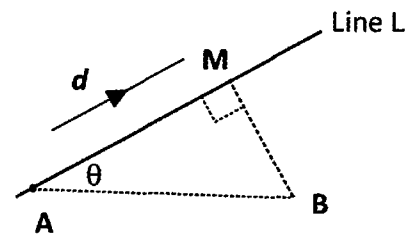

- Hence, the shortest distance between the point with position vector \mathbf{b} and the line with equation $\mathbf{r} = \mathbf{a} + \lambda\mathbf{d}$ is $|(\mathbf{b} - \mathbf{a}) \times \hat{\mathbf{d}}|$.

Example 7.27

Without the use of a calculator, find the minimum distance between the point P with position vector $\langle 2, 1, 4 \rangle$ and the line L with equation $\mathbf{r} = \langle 2 + \lambda, -\lambda, -1 - \lambda \rangle$.

Solution:

Let M be the foot of the perpendicular from B to the line L.

$$\begin{aligned} \mathbf{PM} &= \langle 2 + \lambda, -\lambda, -1 - \lambda \rangle - \langle 2, 1, 4 \rangle \\ &= \langle \lambda, -\lambda - 1, -\lambda - 5 \rangle \end{aligned}$$

Direction vector of line is $\mathbf{d} = \langle 1, -1, -1 \rangle$.

$$\begin{aligned} \Rightarrow \langle \lambda, -\lambda - 1, -\lambda - 5 \rangle \cdot \langle 1, -1, -1 \rangle &= 0 \\ \Rightarrow \lambda &= -2 \end{aligned}$$

Hence, shortest distance between P and given line

$$\begin{aligned} &= |\langle \lambda, -\lambda - 1, -\lambda - 5 \rangle| \\ &= |\langle -2, 1, -3 \rangle| = \sqrt{14} \end{aligned}$$

```
[2, 1, 4] → p
define m(x)=[2+x, -x, -1-x]
m(x)-p
dotP([x -x-1 -x-5], [1, -1, -1])
solve(3*x+6=0, x)
norm(m(-2)-p)
```

[2 1 4] done
[x -x-1 -x-5] 3*x+6
{x=-2} √14

Alternative method using the cross product

Equation of line: $\mathbf{r} = \langle 2 + \lambda, -\lambda, -1 - \lambda \rangle \Rightarrow$ A point on the line is $\langle 2, 0, -1 \rangle$.

Direction vector of line $\mathbf{d} = \langle 1, -1, -1 \rangle \Rightarrow \hat{\mathbf{d}} = \frac{1}{\sqrt{3}} \langle 1, -1, -1 \rangle$.

$$\begin{aligned} \text{Hence, shortest distance is} &= |(\langle 2, 1, 4 \rangle - \langle 2, 0, -1 \rangle) \times \frac{1}{\sqrt{3}} \langle 1, -1, -1 \rangle| \\ &= \frac{1}{\sqrt{3}} |\langle 0, 1, 5 \rangle \times \langle 1, -1, -1 \rangle| \\ &= \frac{1}{\sqrt{3}} \left| \begin{vmatrix} 1 & -1 \\ 5 & -1 \end{vmatrix}, - \begin{vmatrix} 0 & 1 \\ 5 & -1 \end{vmatrix}, \begin{vmatrix} 0 & 1 \\ 1 & -1 \end{vmatrix} \right| = \frac{1}{\sqrt{3}} |\langle 4, 5, -1 \rangle| \\ &= \sqrt{14} \end{aligned}$$

Alternative method using CAS calculator

Let M be a point on the line L.

$$\mathbf{PM} = \langle 2 + \lambda, -\lambda, -1 - \lambda \rangle - \langle 2, 1, 4 \rangle = \langle \lambda, -\lambda - 1, -\lambda - 5 \rangle$$

Using fMin command:

minimum value for $|\mathbf{PM}| = \sqrt{14}$.

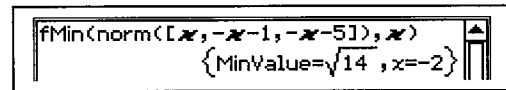
**7.5.2 Shortest Distance between point and plane: Scalar Projection Method**

- It is required to find the shortest distance between a point A with position vector \mathbf{a} and the plane Π with equation $\mathbf{r} \cdot \mathbf{n} = \rho$.
- Let B be any point on the plane Π .
- The shortest distance between A and the plane Π is $|\mathbf{KA}|$ where K is the foot of the perpendicular from A to the plane.
- But $|\mathbf{KA}| = \text{scalar projection of } \mathbf{BA} \text{ onto } \mathbf{n}, \text{ the vector normal to the plane}$
 $= |\mathbf{BA} \cdot \hat{\mathbf{n}}| = |(\mathbf{a} - \mathbf{b}) \cdot \hat{\mathbf{n}}|$
- Hence, the shortest distance between A with position vector \mathbf{a} and the plane $\mathbf{r} \cdot \mathbf{n} = \rho$ is given by the $|(\mathbf{a} - \mathbf{b}) \cdot \hat{\mathbf{n}}|$ where \mathbf{b} is the position vector of any point on the plane. The absolute value is necessary to account for the fact that A could sometimes be “above” or “below” the plane.
- Consider the plane with equation $\mathbf{r} \cdot \hat{\mathbf{n}} = \rho$ (the normal vector is a unit vector).
 - The shortest distance between the plane and the origin is $|(\mathbf{0} - \mathbf{b}) \cdot \hat{\mathbf{n}}| = |\mathbf{b} \cdot \hat{\mathbf{n}}|$ where \mathbf{b} is any point on the plane.
 - Since \mathbf{b} is on the plane, $\mathbf{b} \cdot \hat{\mathbf{n}} = \rho$. Hence, the shortest distance is $|\rho|$.
- Therefore the shortest distance between the plane $\mathbf{r} \cdot \mathbf{n} = \rho$ and the origin is $\left| \frac{\rho}{|\hat{\mathbf{n}}|} \right|$.

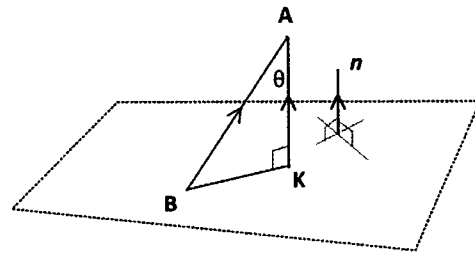

Example 7.28

Find the shortest distance between the point A with position vector $\langle 2, 3, -4 \rangle$ and the plane with equation $\mathbf{r} \cdot \langle 1, 2, -2 \rangle = 7$.

Solution:

The point with position vector $\langle 1, 3, 0 \rangle$ is a point on the given plane as $\langle 1, 3, 0 \rangle \cdot \langle 1, 2, -2 \rangle = 7$.

The normal vector $\mathbf{n} = \langle 1, 2, -2 \rangle$.

Hence $\hat{\mathbf{n}} = \frac{1}{3} \langle 1, 2, -2 \rangle$.

Therefore,

the shortest distance between A and the plane

$$\begin{aligned} &= |[\langle 2, 3, -4 \rangle - \langle 1, 3, 0 \rangle] \cdot \frac{1}{3} \langle 1, 2, -2 \rangle| \\ &= |\langle 1, 0, -4 \rangle \cdot \frac{1}{3} \langle 1, 2, -2 \rangle| \\ &= 3 \text{ units} \end{aligned}$$

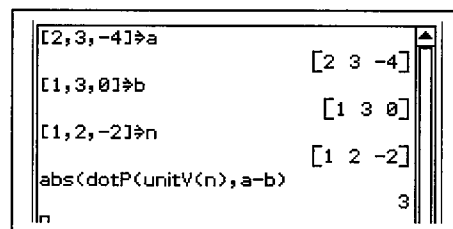
Exercise 7.6

- Use a vector method to find the minimum distance between the point with position vector \mathbf{a} and the given line:
 - $\mathbf{a} = \langle 1, 0, 1 \rangle$ and $\mathbf{r} = \langle 1, 1, -1 \rangle + \lambda \langle 4, -1, 0 \rangle$
 - $\mathbf{a} = \langle -2, 6, -4 \rangle$ and $\mathbf{r} = \langle 0, 2, -5 \rangle + \lambda \langle -2, 0, 4 \rangle$
 - $\mathbf{a} = \langle 0, 0, 0 \rangle$ and $\mathbf{r} = \langle 1 + 3\lambda, -1 + 5\lambda, 4 - \lambda \rangle$
 - $\mathbf{a} = \langle 4, 2, -4 \rangle$ and $\mathbf{r} = \langle 3 - 2\lambda, 4 + \lambda, -3 - \lambda \rangle$
- The minimum distance between the point P with position vector $\langle 1, 0, k \rangle$ and the line $\mathbf{r} = \langle 1, 2, -5 \rangle + \lambda \langle 0, 2, -2 \rangle$ is $5\sqrt{2}$. Find k .
- The minimum distance between the point P with position vector $\langle k, 1, 1 \rangle$ and the line $\mathbf{r} = \langle -2, 0, -1 \rangle + \lambda \langle 2, 1, -1 \rangle$ is $\frac{\sqrt{30}}{2}$. Find k .
- A is a point on the line $\mathbf{r} = \langle 1, -2, 1 \rangle + \lambda \langle -2, 1, -1 \rangle$. B is a point on the line $\mathbf{r} = \langle 2, 1, -1 \rangle + \mu \langle 4, -1, 2 \rangle$.
 - Show that these two lines are non-intersecting.
 - The two lines are closest together when \mathbf{BA} is perpendicular to both lines. Find the closest distance between these two lines.
- A is a point on the line $\mathbf{r} = \langle 1 + \lambda, \lambda, 1 - 3\lambda \rangle$. B is a point on the line $\mathbf{r} = \langle 1 - \lambda, 4 + 3\lambda, -1 + 2\lambda \rangle$.
 - Show that these two lines are non-intersecting.
 - The two lines are closest together when \mathbf{BA} is perpendicular to both lines. Find the closest distance between these two lines.

- *6. Find the minimum distance between the lines:
 (a) $\mathbf{r} = \langle 2, 5, 1 \rangle + \lambda \langle 0, -1, 2 \rangle$ and $\mathbf{r} = \langle 3, 2, 2 \rangle + \lambda \langle 2, 0, -1 \rangle$
 (b) $\mathbf{r} = \langle 1 + \lambda, 4\lambda, 5 \rangle$ and $\mathbf{r} = \langle 2 - \lambda, 3 + \lambda, -\lambda \rangle$.
7. Find the shortest distance between the point with position vector \mathbf{a} and the given plane.
 (a) $\mathbf{a} = \langle 0, 0, 0 \rangle$; $\mathbf{r} \cdot \langle 2, 1, 2 \rangle = 6$ (b) $\mathbf{a} = \langle 0, 0, 0 \rangle$; $\mathbf{r} \cdot \langle 1, 2, -2 \rangle = -6$
 (c) $\mathbf{a} = \langle 4, 0, 3 \rangle$; $\mathbf{r} \cdot \langle 1, 0, 0 \rangle = 5$ (d) $\mathbf{a} = \langle 5, 1, 0 \rangle$; $\mathbf{r} \cdot \langle 0, 1, 0 \rangle = 6$
 (e) $\mathbf{a} = \langle 2, -2, 4 \rangle$; $\mathbf{r} \cdot \langle 1, -1, 2 \rangle = 42$ (f) $\mathbf{a} = \langle 8, 4, -4 \rangle$; $\mathbf{r} \cdot \langle 2, 2, -1 \rangle = 10$.
8. The shortest distance between the point with position vector $\langle 2, b, 5 \rangle$ and the plane $\mathbf{r} \cdot \langle -1, 1, 2 \rangle = 10$ is 10. Find b .
9. The shortest distance between the point with position vector $\langle 1, 5, -1 \rangle$ and the plane $\mathbf{r} \cdot \langle 2, 1, c \rangle = 10$ is 1. Find c .
10. Find the shortest distance between the given line and the given plane:
 (a) $\mathbf{r} = \langle -1 + \lambda, \lambda, 1 - 3\lambda \rangle$, $\mathbf{r} \cdot \langle 3, 0, 1 \rangle = 8$
 (b) $\mathbf{r} = \langle 2 - \lambda, 3 + \lambda, -\lambda \rangle$, $\mathbf{r} \cdot \langle 0, 2, 2 \rangle = 2$.
11. Use a vector method to find the shortest distance between the planes $\mathbf{r} \cdot \langle 2, 2, 1 \rangle = 10$ and $\mathbf{r} \cdot \langle 2, 2, 1 \rangle = 12$.
12. Use a vector method to find shortest distance between the planes $\mathbf{r} \cdot \langle 1, -2, 2 \rangle = 5$ and $\mathbf{r} \cdot \langle -2, 4, -4 \rangle = 8$.
13. Find the shortest distance between the sphere $|\mathbf{r}| = 1$ and the plane $\mathbf{r} \cdot \langle 1, 2, -2 \rangle = 4$.
14. Find the shortest distance between the sphere $|\mathbf{r} - \langle 1, 2, 1 \rangle| = 1$ and the plane $\mathbf{r} \cdot \langle 2, 1, 3 \rangle = 4$.

08 Vectors III

8.1 Vector Functions

- Consider the vector $\mathbf{r} = t\mathbf{i} + 2t\mathbf{j}$ where t is a variable.
As t changes, the vector \mathbf{r} changes.
We describe the vector \mathbf{r} as a vector function of the parameter t .
- The position of a moving object can be described in vector form by stating its coordinates in terms of time t . The x and y components (or z component) are expressed as functions of time.

Example 8.1

The position vector of a moving particle at time t seconds is given by $\mathbf{r}(t) = \langle 2, 4 \rangle + t \langle 1, -1 \rangle$. Find the Cartesian equation of the path of this particle.

Solution:

$$\begin{aligned} \text{Parametric equation of path:} \quad x(t) &= 2 + t \\ y(t) &= 4 - t \end{aligned}$$

$$\text{Hence, Cartesian equation is} \quad x + y = 6$$

Example 8.2

The position vector of a moving particle at time t seconds is given by

$$\mathbf{r}(t) = \begin{pmatrix} t+1 \\ t^2-1 \end{pmatrix}. \text{ Find the Cartesian equation of the path of this particle.}$$

Solution:

$$\begin{aligned} \text{Parametric equation of path:} \quad x &= t + 1 \\ y &= t^2 - 1 \end{aligned}$$

$$\text{Rewrite} \quad t = x - 1$$

Substitute into y :

$$\text{Hence, Cartesian equation is} \quad y = (x - 1)^2 - 1.$$

That is, the path traced by the particle is a parabola.

Example 8.3

The position vector of a point P at time t seconds, is given by $\mathbf{r}(t) = 2 \cos(t) \mathbf{i} + 3 \sin(t) \mathbf{j}$. Determine the parametric equation and Cartesian equation of the path traced by P. Sketch the path, indicating its direction.

Solution:

The parametric equation of the path is

$$x = 2 \cos(t) \quad y = 3 \sin(t)$$

Rewriting the parametric equation,

$$\cos(t) = \frac{x}{2} \quad \sin(t) = \frac{y}{3}$$

But $\cos^2 t + \sin^2 t = 1$:

$$\Rightarrow \text{Cartesian equation of the path is } \frac{x^2}{4} + \frac{y^2}{9} = 1.$$

That is, the path traced by the point P is an ellipse.

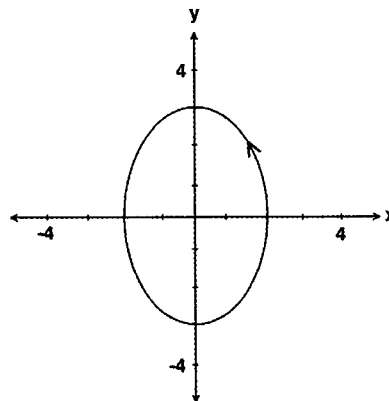

The sketch of the path is given in the accompanying diagram.

Direction of motion: $\mathbf{r}(0) = \langle 2, 0 \rangle$

Close to $t = 0$, as t increases, x decreases and y increases.

Hence, P moves in an anti-clockwise direction from the point $(2, 0)$

Exercise 8.1

1. Find the Cartesian equation of the path traced by the point P with position vector $\mathbf{r}(t)$, where t represents time. Sketch the path, indicating the direction of motion.

(a) $\mathbf{r} = 2t \mathbf{i}$

(b) $\mathbf{r} = -4t \mathbf{j}$

(c) $\mathbf{r} = t \mathbf{i} + 4 \mathbf{j}$

(d) $\mathbf{r} = -3 \mathbf{i} + t \mathbf{j}$

(e) $\mathbf{r} = -t \mathbf{i} + 2t \mathbf{j}$

(f) $\mathbf{r} = (1 - t) \mathbf{i} + t \mathbf{j}$

(g) $\mathbf{r} = t \mathbf{i} + t^2 \mathbf{j}$

(h) $\mathbf{r} = t^2 \mathbf{i} + t \mathbf{j}$

(i) $\mathbf{r} = (1 + t^2) \mathbf{i} + 2t \mathbf{j}$

(j) $\mathbf{r} = (1 + t) \mathbf{i} - t^3 \mathbf{j}$

(k) $\mathbf{r} = t \mathbf{i} + t e^t \mathbf{j}$

(l) $\mathbf{r} = \left(\frac{1}{t}\right) \mathbf{i} + \left(t - \frac{1}{t}\right) \mathbf{j}$

2. Find the Cartesian equation of the path traced by the point P with position vector $\mathbf{r}(t)$, where t represents time. Sketch the path, indicating the direction of motion.

(a) $\mathbf{r} = \langle \sin(t), \cos(t) \rangle$

(b) $\mathbf{r} = \langle \cos(t), 2 \sin(t) \rangle$

(c) $\mathbf{r} = \langle -2 \sin(t), \cos(t) \rangle$

(d) $\mathbf{r} = \langle 3 \cos(2t), 2 \sin(2t) \rangle$

(e) $\mathbf{r} = \langle 1 + \cos(t), 2 - \sin(t) \rangle$

(f) $\mathbf{r} = \langle 1 - 2 \sin(t), 4 + \cos(t) \rangle$

(g) $\mathbf{r} = \langle \sin(2t), \cos(2t) \rangle$

(h) $\mathbf{r} = \langle \sin(2t), \cos(t) \rangle$

8.2 Applications involving vector functions

- In this section we will work with particles moving in a plane as well as in space.

Example 8.4

At 0600 hours, particle A starts moving with constant velocity $\langle 1, 3, -5 \rangle \text{ ms}^{-1}$ from the point with position vector $\langle 2, 1, -5 \rangle$ metres.

- Find the position vector of A after 5 seconds
- Find when A is 100 metres from the origin.

Solution:

- Position vector of A after 5 seconds

$$\mathbf{OA}(5) = \langle 2, 1, -5 \rangle + 5 \times \langle 1, 3, -5 \rangle = \langle 7, 16, -30 \rangle \text{ m.}$$

- Position vector of A after t seconds

$$\begin{aligned} \mathbf{OA}(t) &= \langle 2, 1, -5 \rangle + t \times \langle 1, 3, -5 \rangle \\ &= \langle 2+t, 1+3t, -5-5t \rangle \end{aligned}$$

Hence, Distance to the origin

$$|\mathbf{OA}(t)| = \sqrt{(2+t)^2 + (1+3t)^2 + (-5-5t)^2}.$$

When distance = 100 m:

$$\sqrt{(2+t)^2 + (1+3t)^2 + (-5-5t)^2} = 100$$

Use the “Solve” command: $\Rightarrow t = 16.04$ (reject -17.76)

Hence, A is 100 metres away from the origin 16 seconds after 0600 hours.

```
Define a(t)=[2,1,-5]+t*[1,3,-5]
done
a(5)
[7 16 -30]
solve(norm(a(t))=100,t)
{t=-17.7566,t=16.0423}
□
```

Example 8.5

At 0800 hours, the position vectors of objects A and B are $\langle -25, 10, 40 \rangle$ km and $\langle 50, -20, 10 \rangle$ km respectively. A and B travel with constant velocity $\langle 10, -5, -5 \rangle$ and $\langle -5, 5, -10 \rangle \text{ kmh}^{-1}$ respectively.

- Find the position vectors of A and B t hours after 0800 hours.
- Find when A and B are 60 km apart.
- Find the minimum distance between A and B and state when this occurs.

Solution:

- Position vector of A after t hours $\mathbf{OA}(t) = \langle -25, 10, 40 \rangle + t \times \langle 10, -5, -5 \rangle$
 $= \langle -25 + 10t, 10 - 5t, 40 - 5t \rangle$

$$\begin{aligned} \text{Position vector of B after } t \text{ hours } \mathbf{OB}(t) &= \langle 50, -20, 10 \rangle + t \times \langle -5, 5, -10 \rangle \\ &= \langle 50 - 5t, -20 + 5t, 10 - 10t \rangle \end{aligned}$$

(b) Displacement vector between A and B after t hours $\mathbf{AB}(t) = \mathbf{OB}(t) - \mathbf{OA}(t)$

$$\begin{aligned}\mathbf{AB}(t) &= \langle 50 - 5t, -20 + 5t, 10 - 10t \rangle - \langle -25 + 10t, 10 - 5t, 40 - 5t \rangle \\ &= \langle 75 - 15t, -30 + 10t, -30 - 5t \rangle.\end{aligned}$$

Distance between A and B after t hours = $|\mathbf{AB}(t)|$.

But, $|\mathbf{AB}(t)| = 60$.

$$\text{Hence, } \sqrt{(75-15t)^2 + (-30+10t)^2 + (-30-5t)^2} = 60$$

$$\Rightarrow t = 2.1126, 5.1732 \text{ hours.}$$

Hence, A and B are 60 km apart at 1007 hours and 1310 hours.

(c) Distance between A and B,

$$d = \sqrt{(75-15t)^2 + (-30+10t)^2 + (-30-5t)^2};$$

Use “fMin” command:

Minimum value for AB = 52.7 km

when $t = 3.6429$ hours i.e. 1139 hours.

```

Define a(x)=[-25,10,40]+x*[10,-5,-5]
done
Define b(x)=[50,-20,10]+x*[-5,5,-5]
done
solve(norm(b(x))-a(x))=60,x
{t=2.1126,t=5.1732}
fMin(norm(b(x))-a(x),x,0,12)
{MinValue=52.7291,t=3.6429}
  
```

Example 8.6

At 6.00 am, the position and velocity vectors of objects A, B and C are respectively $\langle -20, 50, 40 \rangle$ km, $\langle 15, -5, 4 \rangle$ kmh⁻¹; $\langle 50, -10, 20 \rangle$ km, $\langle -20, 25, 14 \rangle$ kmh⁻¹ and $\langle 10, 60, -10 \rangle$ km and $\langle 0, -10, 25 \rangle$ kmh⁻¹. If the respective velocities are maintained, show that: (a) A and B will collide, stating when this will occur, (b) A and C will not collide.

Solution:

Position vector of A after t hours $\mathbf{OA}(t) = \langle -20 + 15t, 50 - 5t, 40 + 4t \rangle$.

Position vector of B after t hours $\mathbf{OB}(t) = \langle 50 - 20t, -10 + 25t, 20 + 14t \rangle$.

Position vector of C after t hours $\mathbf{OC}(t) = \langle 10, 60 - 10t, -10 + 25t \rangle$.

(a) For A and B to collide, $\mathbf{OA}(t) = \mathbf{OB}(t)$;

$$\Rightarrow \langle -20 + 15t, 50 - 5t, 40 + 4t \rangle = \langle 50 - 20t, -10 + 25t, 20 + 14t \rangle.$$

Comparing i components: $-20 + 15t = 50 - 20t \Rightarrow t = 2$

Comparing j components: $50 - 5t = -10 + 25t \Rightarrow t = 2$

Comparing k components: $40 + 4t = 20 + 14t \Rightarrow t = 2$

Since, the i, j and k components of \mathbf{OA} and \mathbf{OB} are identical for $t = 2$,

A and B collide at 8.00 am.

(b) For A and C to collide, $\mathbf{OA}(t) = \mathbf{OC}(t)$;

$$\Rightarrow \langle -20 + 15t, 50 - 5t, 40 + 4t \rangle = \langle 10, 60 - 10t, -10 + 25t \rangle.$$

Comparing i components: $-20 + 15t = 10 \Rightarrow t = 2$

Comparing j components: $50 - 5t = 60 - 10t \Rightarrow t = 2$

Comparing k components: $40 + 4t = -10 + 25t \Rightarrow t = 50/21 \neq 2$

Since, the i, j and k components of \mathbf{OA} and \mathbf{OC} do not produce a common value for t ,

A and C will not collide.

Example 8.7

The position vectors of two moving objects A and B at time t hours are given by $r_A = \langle 1 + t, -2 + 2t, t + 4 \rangle$ and $r_B = \langle 5 - t, 1 + t, 2t + 3 \rangle$ respectively.

- (a) Show that the two objects do not collide.
- (b) State the coordinates of the point of intersection of the paths of these two objects, if it exists.

Solution:

(a) At collision: $\langle 1 + t, -2 + 2t, t + 4 \rangle = \langle 5 - t, 1 + t, 2t + 3 \rangle$

Comparing i components: $1 + t = 5 - t \Rightarrow t = 2$

Comparing j components: $-2 + 2t = 1 + t \Rightarrow t = 3 \neq 2$

Since, the i , and j components do not produce a common value for t , A and B will not collide.

(b) Equation of path for A is of the form $r_A = \langle 1 + a, -2 + 2a, a + 4 \rangle$.

Equation of path for B is of the form $r_B = \langle 5 - b, 1 + b, 2b + 3 \rangle$.

At the point of intersection:

$$\langle 1 + a, -2 + 2a, a + 4 \rangle = \langle 5 - b, 1 + b, 2b + 3 \rangle$$

Solve simultaneously: $1 + a = 5 - b$

$$-2 + 2a = 1 + b$$

$$a + 4 = 2b + 3$$

$$\Rightarrow a = \frac{7}{3}, b = \frac{5}{3}$$

Hence, point of intersection of paths is $\left(\frac{10}{3}, \frac{8}{3}, \frac{19}{3}\right)$.

Handwritten solution for finding the intersection point of two paths. It shows a system of three equations: $1+x=5-y$, $-2+2x=1+y$, and $x+4=2y+3$. The solution found is $x = \frac{7}{3}$ and $y = \frac{5}{3}$. Then, the coordinates of the intersection point are calculated as $\left(\frac{10}{3}, \frac{8}{3}, \frac{19}{3}\right)$.

Note:

- In this example, the two objects do not collide but the paths do intersect.

Exercise 8.2

1. The position vector of a moving body P at time t is given by $r = 2t\mathbf{i} - 4t\mathbf{j}$. The position vector of a second moving body Q at time t is given by $r = (2 + t)\mathbf{i} + \left(\frac{t}{2} - 9\right)\mathbf{j}$.

- (a) Determine if the two bodies collide and give the time of collision if collision occurs.
- (b) Determine the vector equations of the paths of A and B.
Hence, or otherwise, determine the point of intersection of the two paths.

2. The position vector of a moving body P at time t is given by $r = t\mathbf{i} + (1 + t)\mathbf{j}$. The position vector of a second moving body Q at time t is given by $r = (2t - 1)\mathbf{i} + 3t\mathbf{j}$.

- (a) Determine if the two bodies collide and give the time of collision if collision occurs.
- (b) Determine the vector equations of the paths of A and B.
Hence, or otherwise, determine the point of intersection of the two paths.

3. At 1000 hours, particle B starts moving from the point $P < 5, 2, -10 >$ metres with velocity $< 1, 1, 5 > \text{ms}^{-1}$. Find: (a) the position vector of B after t seconds
(b) when B is 100 metres from P
(c) when B is 100 metres from the point Q with position vector $< 6, 8, 20 >$.
4. Particle D travels with a constant velocity of $< a, b, c > \text{ms}^{-1}$ and passes the points $< 10, -40, 40 > \text{m}$ and $< 0, -20, 10 > \text{m}$ at 6 am and 8 am respectively. Find:
(a) a, b and c (b) when and where D crosses the x - z plane.
5. At 0800 hours, the position vectors of objects A and B are $< 150, -100, 400 > \text{m}$ and $< 550, -400, -200 > \text{m}$ respectively. A and B travel with constant velocity $< 50, -20, -50 >$ and $< -25, 50, 40 > \text{ms}^{-1}$ respectively.
(a) Find when A and B are 150 km apart.
(b) Find the minimum distance between A and B and state when this occurs.
6. At 12 noon, object H travelling with constant velocity $< 90, -100, 100 > \text{ms}^{-1}$ is sighted at the point with position vector $< 0, -100, 200 > \text{m}$. At 1.00 pm object J travelling with constant velocity $< -50, 100, 100 > \text{ms}^{-1}$ is sighted at the point with position vector $< -200, -240, -200 > \text{m}$ respectively. Use vector methods to find:
(a) the minimum distance between H and J and state when this occurs
(b) when H and J are 1000 m apart.
7. At 0800 hours, the position and velocity vectors of particles A and B are respectively $< 100, 90, 80 > \text{m}$, $< 10, -40, 60 > \text{ms}^{-1}$ and $< -200, 150, -80 > \text{m}$ and $< 22, -42.4, 66.4 > \text{ms}^{-1}$. If these velocities were maintained show that A and B will collide stating when and where the collision will occur.
8. At 6 am, hot-air balloons A and B leave their anchorage points located at $< -20, 50, 0.2 >$ km and $< 7, 80, 0.35 >$ km with constant velocities $< 20, 80, 0.8 > \text{kmh}^{-1}$ and $< -16, 40, 0.6 > \text{kmh}^{-1}$ respectively. Use a relative velocity method to show that if these velocities are maintained, A and B will collide. State where and when this collision will occur.
9. At 2 pm, remotely controlled drone P leaves its base located at $< 50, -20, -0.3 >$ nautical miles with constant velocity $< 70, 50, 2 >$ knots. One hour later, another drone Q leaves a base located at $< 345, 165, 0.2 >$ nautical miles with constant velocity $< -80, -40, 3 >$ knots. Use a relative velocity method to show that if these velocities are maintained, Q will intercept P. State where and when this interception will occur.
10. At 7.00 am, the position and velocity vectors of particles A, B and C are respectively $< 1, 5, -10 > \text{km}$, $< 6, 4, 5 > \text{kmh}^{-1}$; $< 6, -5, 20 > \text{km}$, $< 3, 6, -1 > \text{kmh}^{-1}$ and $< 9, 1, 2 > \text{km}$ and $< 4, 5, 2 > \text{kmh}^{-1}$. If these velocities were maintained, use vector methods to determine which of these particles will collide. State when and where the collision(s) will occur.

11. The position vectors of submarines R and S at time t seconds are given by
 $\mathbf{r}_R = \langle 0, -500, -40 \rangle + t \langle x, y, z \rangle$ m and
 $\mathbf{r}_S = \langle 800, -1300, -80 \rangle + t \langle 4, 6, -0.15 \rangle$ m respectively.
- Find in terms of x , y and z , the velocity of R relative to S.
 - Find the initial displacement of S relative to R.
 - Given that $|\langle x, y, z \rangle| = \sqrt{50.04} \text{ ms}^{-1}$, and all velocities are maintained with the two submarines eventually colliding, use your answers in (a) and (b) to find x , y and z .
12. The position vectors of objects A and B at time t seconds are given by
 $\mathbf{r}_A = \langle 1, 2, -4 \rangle + t \langle -1, 2, 0.1 \rangle$ m and $\mathbf{r}_B = \langle -19, -13, -1 \rangle + t \langle x, y, z \rangle$ m respectively. Given that $|\langle x, y, z \rangle| = \sqrt{10}$, and all velocities are maintained with the two objects eventually colliding, use a relative velocity method to determine x , y and z .
13. Find the point of intersection (if they exist) of the paths of the particles A and B as given below:
- $\mathbf{r}_A(0) = \langle 0, 0, 0 \rangle$ m, $\mathbf{v}_A = \langle 0, 0, 0 \rangle$ m/s;
 $\mathbf{r}_B(0) = \langle 6, 10, -10 \rangle$ m and $\mathbf{v}_B = \langle -2, 1, 2 \rangle$ m/s
 - $\mathbf{r}_A(0) = \langle -10, 5, 10 \rangle$ m, $\mathbf{v}_A = \langle 0, 0, 0 \rangle$ m/s;
 $\mathbf{r}_B(0) = \langle 0, 0, 0 \rangle$ m and $\mathbf{v}_B = \langle -2, 1, 2 \rangle$ m/s
 - $\mathbf{r}_A(0) = \langle 20, -5, -10 \rangle$ m, $\mathbf{v}_A = \langle 10, -5, -14 \rangle$ m/s;
 $\mathbf{r}_B(0) = \langle -30, 10, 8 \rangle$ m and $\mathbf{v}_B = \langle 20, -5, -2 \rangle$ m/s
 - $\mathbf{r}_A(0) = \langle 80, -70, 200 \rangle$ m, $\mathbf{v}_A = \langle -20, -10, -40 \rangle$ m/s;
 $\mathbf{r}_B(0) = \langle -10, -100, 90 \rangle$ m and $\mathbf{v}_B = \langle 30, 30, 10 \rangle$ m/s
14. At 8 am, the position vectors of unmanned aerial vehicles A and B are
 $\langle -200, 100, 2 \rangle$ km and $\langle 100, -20, 1 \rangle$ km respectively. A and B travel with constant velocity $\langle 70, 250, 1 \rangle$ and $\langle -30, 70, 2 \rangle \text{ kmh}^{-1}$ respectively. Determine if the two vehicles collide or if the paths of these two vehicles intersect or none of the above.
15. At 1 pm, object E flying with constant velocity $\langle 10, 10, 0.3 \rangle \text{ ms}^{-1}$ is sighted at the point with position vector $\langle 20, 0, -1.4 \rangle$ m. At 1 pm object F flying with constant velocity $\langle 8, 10, 0.2 \rangle \text{ ms}^{-1}$ is sighted at the point with position vector $\langle 30, -90, 0.9 \rangle$ m. Determine if these two objects collide or if the paths of these two objects intersect or none of the above.

09 Geometric Proofs using Vectors

9.1 Plane Geometry

- This section *extends* the work started in the previous unit (Chapter 12 of Units 1 & 2) on the use of vector methods to prove properties of several planar shapes.

Example 9.1 *Internal Division of a line segment*

The collinear points A, B and C have position vectors \mathbf{a} , \mathbf{b} and \mathbf{c} respectively. The point B divides the line segment AC internally in the ratio $\lambda : \mu$, where $\lambda > 0$ and $\mu > 0$.

That is, $\mu\mathbf{AB} = \lambda\mathbf{BC}$. Prove that $\mathbf{b} = \frac{1}{\lambda + \mu}(\mu\mathbf{a} + \lambda\mathbf{c})$.

Solution:

$$\begin{aligned}\mu\mathbf{AB} = \lambda\mathbf{BC} &\Rightarrow \mu(\mathbf{b} - \mathbf{a}) = \lambda(\mathbf{c} - \mathbf{b}) \\ \mu\mathbf{b} + \lambda\mathbf{b} &= \lambda\mathbf{c} + \mu\mathbf{a} \\ \mathbf{b} &= \frac{1}{\lambda + \mu}(\mu\mathbf{a} + \lambda\mathbf{c}).\end{aligned}$$

Example 9.2 *The Cauchy–Schwarz Inequality & The Triangular Inequality*

Given the vectors \mathbf{a} and \mathbf{b} , prove that:

- (a) $|\mathbf{a} \cdot \mathbf{b}| \leq |\mathbf{a}| |\mathbf{b}|$ *The Cauchy–Schwarz Inequality*
 (b) $|\mathbf{a} + \mathbf{b}| \leq |\mathbf{a}| + |\mathbf{b}|$. *The Triangular Inequality*

Solution:

- (a) $\mathbf{a} \cdot \mathbf{b} = |\mathbf{a}| |\mathbf{b}| \cos \theta$ where θ is the angle between \mathbf{a} and \mathbf{b} .

$$|\mathbf{a} \cdot \mathbf{b}| = |\mathbf{a}| |\mathbf{b}| |\cos \theta|$$

$$\text{But } -1 \leq \cos \theta \leq 1 \Rightarrow |\cos \theta| \leq 1$$

$$\text{Hence, } |\mathbf{a} \cdot \mathbf{b}| \leq |\mathbf{a}| |\mathbf{b}|.$$

- (b) $|\mathbf{a} + \mathbf{b}|^2 = (\mathbf{a} + \mathbf{b}) \cdot (\mathbf{a} + \mathbf{b})$

$$= \mathbf{a} \cdot \mathbf{a} + \mathbf{b} \cdot \mathbf{b} + 2\mathbf{a} \cdot \mathbf{b}$$

$$= |\mathbf{a}|^2 + |\mathbf{b}|^2 + 2\mathbf{a} \cdot \mathbf{b}$$

$$\text{Since } |\mathbf{a} \cdot \mathbf{b}| \leq |\mathbf{a}| |\mathbf{b}| \Rightarrow \mathbf{a} \cdot \mathbf{b} \leq |\mathbf{a}| |\mathbf{b}|.$$

$$\text{Hence, } |\mathbf{a} + \mathbf{b}|^2 \leq |\mathbf{a}|^2 + |\mathbf{b}|^2 + 2|\mathbf{a}| |\mathbf{b}|$$

$$\leq (|\mathbf{a}| + |\mathbf{b}|)^2$$

$$\Rightarrow |\mathbf{a} + \mathbf{b}| \leq |\mathbf{a}| + |\mathbf{b}|.$$

Example 9.3 *Property of a rhombus*

Prove that the diagonals of a rhombus are perpendicular.

Solution:

Let OABC be a rhombus with OA parallel to CB.

Let $\mathbf{OA} = \mathbf{a}$ and $\mathbf{OC} = \mathbf{c}$.

As OABC is a rhombus, $|\mathbf{a}| = |\mathbf{c}|$.

Diagonals: $\mathbf{OB} = \mathbf{a} + \mathbf{c}$
 $\mathbf{AC} = -\mathbf{a} + \mathbf{c}$

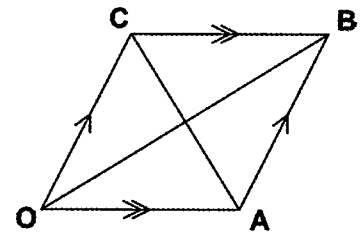

$$\begin{aligned} \mathbf{OB} \cdot \mathbf{AC} &= (\mathbf{a} + \mathbf{c}) \cdot (-\mathbf{a} + \mathbf{c}) \\ &= -\mathbf{a} \cdot \mathbf{a} + \mathbf{a} \cdot \mathbf{c} - \mathbf{c} \cdot \mathbf{a} + \mathbf{c} \cdot \mathbf{c} \\ &= -|\mathbf{a}|^2 + |\mathbf{c}|^2 \\ &= 0 \end{aligned}$$

Hence, the diagonals are perpendicular.

Example 9.4 *Area of Parallelogram*

OABC is a parallelogram with OA parallel to CB. Let $\mathbf{OA} = \mathbf{a}$ and $\mathbf{OC} = \mathbf{c}$. Prove that the area of the parallelogram OABC is $|\mathbf{a} \times \mathbf{c}|$.

Solution:

Let θ be the angle between \mathbf{a} and \mathbf{c} .

Let K be the foot of the perpendicular from C to OA.

Hence, $|\mathbf{CK}| = |\mathbf{OC}| \sin \theta$
 $= |\mathbf{c}| \sin \theta$.

$$\begin{aligned} \text{Area of OABC} &= |\mathbf{OA}| \times |\mathbf{CK}| \\ &= |\mathbf{a}| \times |\mathbf{c}| \sin \theta \\ &= |\mathbf{a} \times \mathbf{c}|. \end{aligned}$$

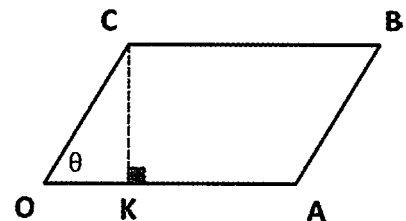

Exercise 9.1

1. The collinear points A, B and C have position vectors \mathbf{a} , \mathbf{b} and \mathbf{c} respectively. The point B divides the line segment AC externally in the ratio $\lambda : \mu$ where $\lambda > 0$ and $\mu > 0$.

That is, $\mu\mathbf{AB} = \lambda\mathbf{CB}$. Prove that $\mathbf{b} = \frac{1}{\mu - \lambda}(\mu\mathbf{a} - \lambda\mathbf{c})$.

2. The collinear points A, B and C have position vectors \mathbf{a} , \mathbf{b} and \mathbf{c} respectively. The point B divides the line segment AC in the ratio $-\lambda : \mu$ where $\lambda > 0$ and $\mu > 0$.

That is, $\mu\mathbf{BA} = \lambda\mathbf{BC}$. Prove that $\mathbf{b} = \frac{1}{\mu - \lambda}(\mu\mathbf{a} - \lambda\mathbf{c})$.

3. Given the vectors \mathbf{a} and \mathbf{b} , prove that:
- (a) $||\mathbf{a}| - |\mathbf{b}|| \leq |\mathbf{a} - \mathbf{b}|$
- (b) $|\mathbf{a} + \mathbf{b}|^2 + |\mathbf{a} - \mathbf{b}|^2 = 2|\mathbf{a}|^2 + 2|\mathbf{b}|^2$.
4. Consider $\triangle OAB$ with $\mathbf{OA} = \mathbf{a}$ and $\mathbf{OB} = \mathbf{b}$. If OM is a median of the triangle, prove that $\mathbf{OM} = \frac{1}{2}(\mathbf{a} + \mathbf{b})$.
5. In quadrilateral $OABC$, if M and N are the midpoints of OA and CB respectively, prove that $\mathbf{MN} = \frac{1}{2}(\mathbf{OC} + \mathbf{AB})$.
6. Prove that the sum of the lengths of any two sides of any triangle is always greater than the length of the remaining side.
7. Prove that in a parallelogram, the sum of the squares of the lengths of the diagonals is equal to the sum of the squares of the lengths of its sides.
8. Prove that the midpoints of the sides of a quadrilateral form a parallelogram.
9. C is the midpoint of the line segment AB . D is a point not on the line AB such that $DC = CA$. Use vector methods to prove that DA is perpendicular to DB .
- *10. Three line segments are congruent to the non-parallel vectors \mathbf{a} , \mathbf{b} and \mathbf{c} respectively. Prove that these line segments form a triangle *iff* $\mathbf{a} + \mathbf{b} + \mathbf{c} = \mathbf{0}$.

11. $PQRS$ in the accompanying diagram is a convex quadrilateral. The diagonals intersect at O . Prove that the sum of the lengths of any two opposite sides of the quadrilateral will always be less than the sum of the lengths of the two diagonals.

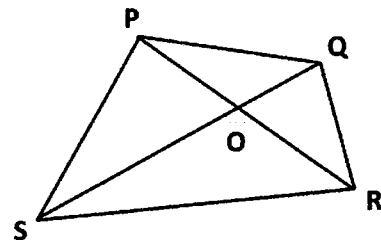

12. O is the centre of a circle circumscribing $\triangle ABC$ with $\mathbf{OA} = \mathbf{a}$, $\mathbf{OB} = \mathbf{b}$ and $\mathbf{OC} = \mathbf{c}$. M is a point such that $\mathbf{OM} = \mathbf{m}$. Prove that if $\mathbf{m} = \mathbf{a} + \mathbf{b} + \mathbf{c}$ then $\mathbf{AM} \cdot \mathbf{BC} = \mathbf{BM} \cdot \mathbf{AC} = \mathbf{CM} \cdot \mathbf{AB} = 0$. [The point O is called the circumcentre and the point M is called the orthocentre of the triangle.]

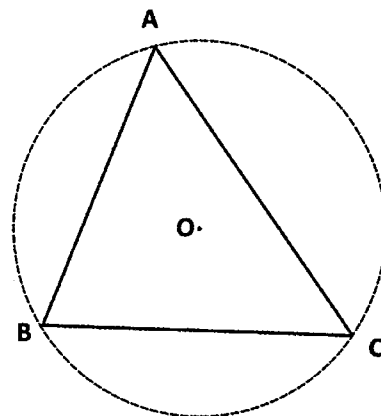

13. Consider $\triangle ABC$ where the vertices have position vectors \mathbf{a} , \mathbf{b} and \mathbf{c} respectively. The point M with position vector \mathbf{m} is the midpoint of the side BC . The point K with position vector \mathbf{k} is such that $\mathbf{AK} = 2\mathbf{KM}$.

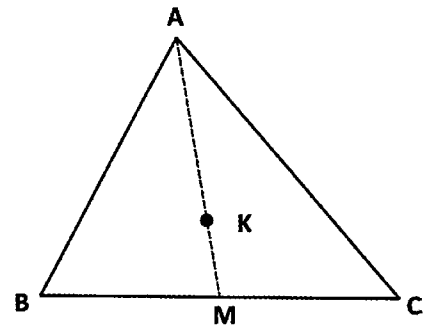

- (a) Prove that $\mathbf{k} = \frac{1}{3}(\mathbf{a} + \mathbf{b} + \mathbf{c})$.
 (b) Hence, deduce that the medians of a triangle are coincident.
 [This point is called the *centroid* of the triangle.]

14. $\triangle OAB$ is such that $\mathbf{OA} = \mathbf{a}$ and $\mathbf{OB} = \mathbf{b}$. Prove that the area of $\triangle OAB = \frac{1}{2} |\mathbf{a} \times \mathbf{b}|$.

15. $OABC$ is parallelogram with $\mathbf{OA} = \mathbf{a}$ and $\mathbf{OC} = \mathbf{c}$. P is a point on OA such that $\mathbf{OP} = \lambda\mathbf{OA}$ where $0 < \lambda < 1$. Q is a point on AB such that $\mathbf{AQ} = \mu\mathbf{AB}$ where $0 < \mu < 1$. Use vector methods to prove that the area of $\triangle CPQ$ cannot exceed half the area of the parallelogram $OABC$.

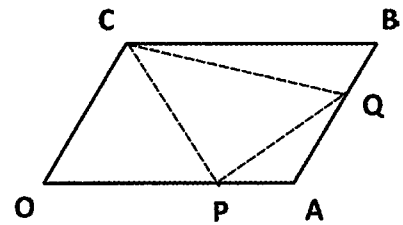

16. Consider $\triangle OAB$ with $\mathbf{OA} = \mathbf{a}$ and $\mathbf{OB} = \mathbf{b}$. P is a point on OA such that $\mathbf{OP} = \lambda\mathbf{OA}$ and S is a point on OB such that $\mathbf{OS} = \lambda\mathbf{OB}$ where $0 < \lambda < 1$. Q and R are points on AB such that $PQRS$ is a parallelogram. Use vector methods to prove that the area of parallelogram $PQRS$ cannot exceed half the area of $\triangle OAB$.

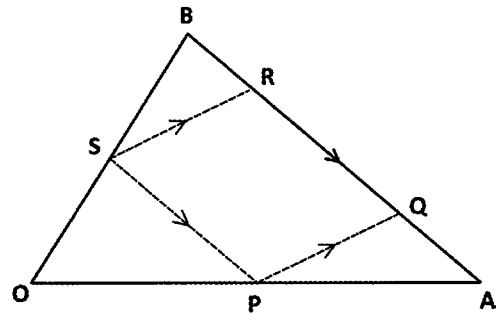

9.2 Geometry in 3D Space

- In this section, we will explore some geometrical properties of shapes in 3D space.

Example 9.5

The point A has position vector $\langle \alpha, \beta, \gamma \rangle$. Prove that the shortest distance between the point

A and the plane $ax + by + cz + d = 0$ is $\left| \frac{a\alpha + b\beta + c\gamma + d}{\sqrt{a^2 + b^2 + c^2}} \right|$.

Solution:

Vector equation of plane is $\mathbf{r} \cdot \langle a, b, c \rangle = -d$.

Clearly, the point with position vector $\langle -\frac{d}{a}, 0, 0 \rangle$ lies on this plane.

Hence, shortest distance between point and plane is:

$$\begin{aligned} D &= \left| \langle \alpha, \beta, \gamma \rangle - \langle -\frac{d}{a}, 0, 0 \rangle \cdot \frac{1}{\sqrt{a^2 + b^2 + c^2}} \langle a, b, c \rangle \right| \\ &= \left| \langle \alpha + \frac{d}{a}, \beta, \gamma \rangle \cdot \frac{1}{\sqrt{a^2 + b^2 + c^2}} \langle a, b, c \rangle \right| \\ &= \left| \frac{a\alpha + b\beta + c\gamma + d}{\sqrt{a^2 + b^2 + c^2}} \right|. \end{aligned}$$

Example 9.6

OABCDEFG is a cuboid (rectangular prism) with $\mathbf{OA} = \mathbf{u}$, $\mathbf{OC} = \mathbf{v}$ and $\mathbf{OE} = \mathbf{w}$. O is the origin of the x - y - z axes. Prove that the volume of the cuboid is $|\mathbf{u} \times \mathbf{v} \cdot \mathbf{w}|$.

Solution:

Area of the base OABC = $|\mathbf{u} \times \mathbf{v}|$.

Height of cuboid is $|\mathbf{w}|$.

Hence, volume of cuboid = $|\mathbf{u} \times \mathbf{v}| |\mathbf{w}|$

But $\mathbf{u} \times \mathbf{v}$ is parallel to \mathbf{w} ,

that is, the angle between $\mathbf{u} \times \mathbf{v}$ and \mathbf{w} is 0° or 180° .

Hence, $\cos 0^\circ = \frac{(\mathbf{u} \times \mathbf{v}) \cdot \mathbf{w}}{|\mathbf{u} \times \mathbf{v}| |\mathbf{w}|}$ or $\cos 180^\circ = \frac{(\mathbf{u} \times \mathbf{v}) \cdot \mathbf{w}}{|\mathbf{u} \times \mathbf{v}| |\mathbf{w}|}$

$$\Rightarrow \pm |\mathbf{u} \times \mathbf{v}| |\mathbf{w}| = (\mathbf{u} \times \mathbf{v}) \cdot \mathbf{w}$$

Hence, $|\mathbf{u} \times \mathbf{v}| |\mathbf{w}| = |(\mathbf{u} \times \mathbf{v}) \cdot \mathbf{w}|$.

Therefore, volume of cuboid is $|\mathbf{u} \times \mathbf{v} \cdot \mathbf{w}|$.

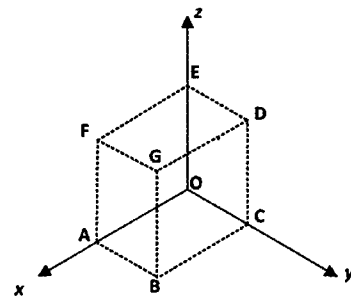

Exercise 9.2

1. OABCDEFG is a rectangular prism. O is the origin of the x - y - z axes. The position vectors of vertices A, C and E are \mathbf{a} , \mathbf{c} and \mathbf{e} respectively.

- (a) Prove that $\mathbf{a} \times \mathbf{c} = \lambda \mathbf{e}$.
 (b) Prove that the area of BCEF is $|\mathbf{a} \times (\mathbf{e} - \mathbf{c})|$.
 (c) M is the midpoint of AB. Prove that the area of $\triangle MED$ is $\frac{1}{2} |\mathbf{c} \times (\mathbf{a} + \frac{1}{2}\mathbf{c} - \mathbf{e})|$.
 (d) Prove that the volume of the wedge OABCGF = $\frac{1}{2} |(\mathbf{a} \times \mathbf{c}) \cdot \mathbf{e}|$.

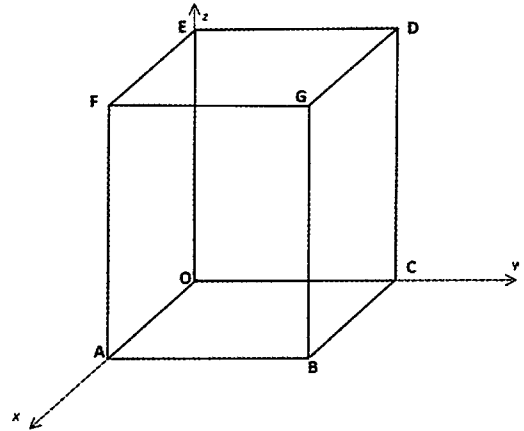

2. OABCDEFG is a cube. O is the origin of the x - y - z axes. The position vectors of vertices A, C and E are \mathbf{a} , \mathbf{c} and \mathbf{e} respectively.

- (a) Show that the equation of the largest possible sphere that can fit into the cube is $|\mathbf{r} - \langle \frac{\mathbf{a}}{2}, \frac{\mathbf{c}}{2}, \frac{\mathbf{e}}{2} \rangle| = \frac{1}{2} |\mathbf{a}|$.
 (b) The cube fits into a sphere. Show that equation of the smallest possible sphere that the cube can fit into is $|\mathbf{r} - \langle \frac{\mathbf{a}}{2}, \frac{\mathbf{c}}{2}, \frac{\mathbf{e}}{2} \rangle| = \frac{1}{2} |\mathbf{a} + \mathbf{c} + \mathbf{e}|$.

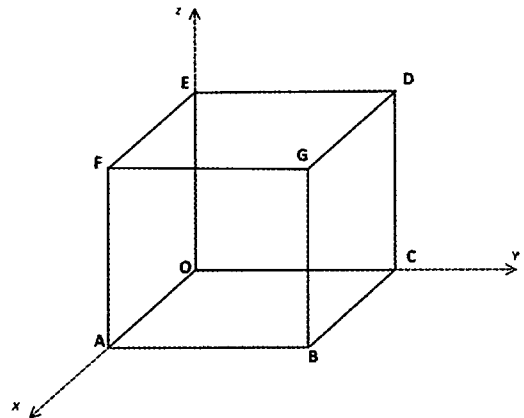

3. OABCDEFG is a parallelepiped. O is the origin of the x - y - z axes. The base OABC is a rectangle. The edges AF, BG, CD and OE are all parallel and congruent. The position vectors of vertices A, C and E are \mathbf{a} , \mathbf{c} and \mathbf{e} respectively. The angle between OE and the z -axis is θ .

- (a) Prove that $\mathbf{OG} + \mathbf{BE} = 2\mathbf{e}$.
 (b) Prove that total surface area of OABCDEFG

$$= 2[|\mathbf{a} \times \mathbf{c}| + |\mathbf{a} \times \mathbf{e}| + |\mathbf{e} \times \mathbf{c}|]$$

 (c) Prove that $\cos \theta = \frac{(\mathbf{a} \times \mathbf{c}) \cdot \mathbf{e}}{|\mathbf{a} \times \mathbf{c}| |\mathbf{e}|}$.

- (d) Prove that the volume of OABCDEFG is $|(\mathbf{a} \times \mathbf{c}) \cdot \mathbf{e}|$.

[The volume of a parallelepiped = Base Area \times Perpendicular Height.]

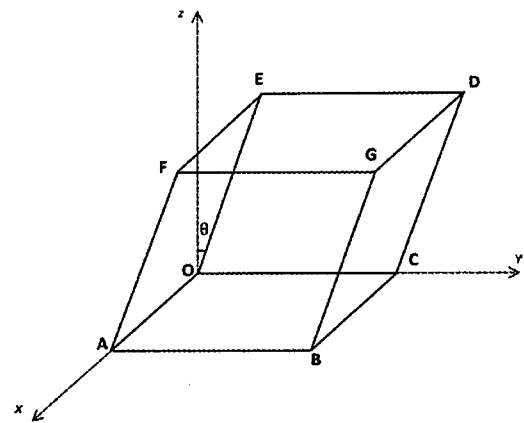

4. VOABC is a rectangular pyramid. O is the origin of the x - y - z axes. The vertex V is vertically above the centre K of the rectangular base OABC. The vertices V, A and C have position vectors \mathbf{v} , \mathbf{a} and \mathbf{c} respectively.

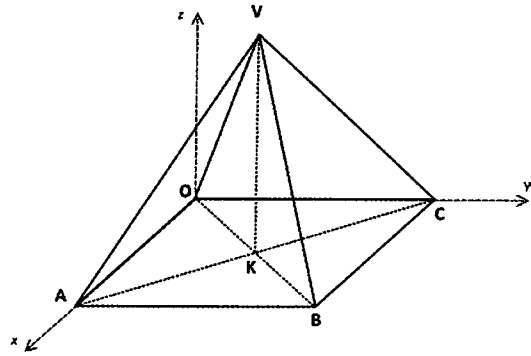

- (a) Prove that the total surface area of the pyramid is $|\mathbf{v} \times \mathbf{a}| + |\mathbf{v} \times \mathbf{c}| + |\mathbf{a} \times \mathbf{c}|$.
 (b) Prove that the area of $\triangle VAC$ is $\frac{1}{2} |(\mathbf{a} - \mathbf{v}) \times (\mathbf{c} - \mathbf{v})|$.

- (c) Prove that the volume of the pyramid is $\frac{1}{3} |(\mathbf{a} \times \mathbf{c}) \cdot (\mathbf{v} - \frac{1}{2}(\mathbf{a} + \mathbf{c}))|$.

5. ABCDEF is a wedge with congruent rectangles ABCD and EFCD with equations

$$\mathbf{r} \cdot \langle 1, 2, 2 \rangle = 10 \text{ and } \mathbf{r} \cdot \langle 2, 1, 2 \rangle = 4$$

respectively. $|\mathbf{DA}| = |\mathbf{DE}| = \sqrt{17}$.

- (a) Prove that CD is parallel to $\langle 2, 2, -3 \rangle$.
 (b) Prove that DE is parallel to $\langle 10, -7, 2 \rangle$.
 (c) Prove that DA is parallel to $\langle 7, -10, -2 \rangle$.

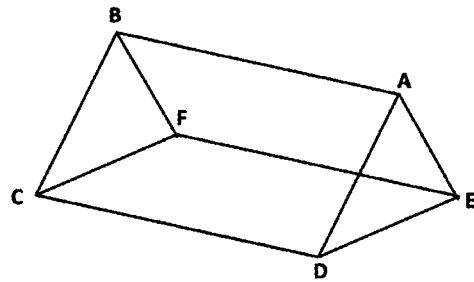

- (d) Prove that the area of $\triangle ADE = \frac{17\sqrt{17}}{18}$.

6. ABCDEF is a wedge with congruent rectangles ABFE and CDEF with equations

$$\mathbf{r} \cdot \langle 1, 1, 2 \rangle = 6 \text{ and } \mathbf{r} \cdot \langle -1, 1, 1 \rangle = 3$$

respectively. $|\mathbf{EA}| = |\mathbf{ED}| = \sqrt{42}$.

- (a) Prove that EF is parallel to $\langle 1, 3, -2 \rangle$.
 (b) Prove that $\angle AED = \cos^{-1}\left(\frac{\sqrt{2}}{3}\right)$.

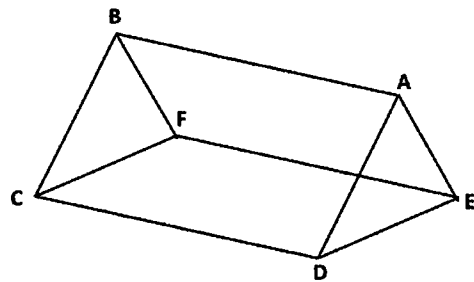

- (c) Use a vector method to prove that the area of $\triangle AED = 7\sqrt{7}$.

10 Systems of Linear Equations

10.1 3×3 Systems

- A 3×3 system refers to a set of 3 simultaneous linear equations in 3 variables.

$$a_0x + a_1y + a_2z = a_3$$

$$b_0x + b_1y + b_2z = b_3$$

$$c_0x + c_1y + c_2z = c_3$$

- As noted in Section 7.3, the equation of a plane may be expressed as a linear equation in three variables. Hence, a system of three linear equations in x , y and z may be expressed geometrically as three *planes* in the x - y - z space.
- For a set of three planes in 3D space, three major scenarios are possible.

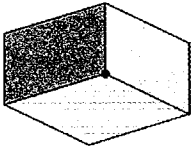
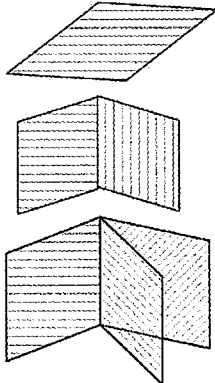
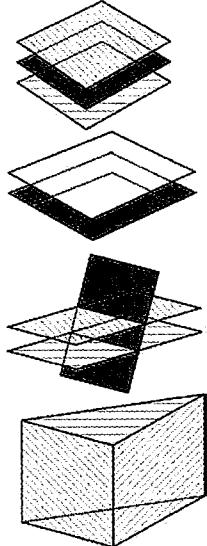
<ul style="list-style-type: none"> The three planes meet at a common point. <ul style="list-style-type: none"> The 3×3 system has a unique set of solutions. 	
<ul style="list-style-type: none"> The three planes are all coincident or two planes are coincident and meet the third plane along a common line or the three planes meet along a common line. <ul style="list-style-type: none"> The 3×3 system has an infinite number of solutions. 	
<ul style="list-style-type: none"> The three planes are all parallel or two planes are coincident and parallel to the third plane or two of the planes are parallel but not the third or the three planes form a prism. <ul style="list-style-type: none"> The 3×3 system has no solution. 	

10.2 3×3 Systems with Unique Solutions

- In this section, we will consider only those 3×3 systems that have unique solutions. We will learn to use the Gaussian elementary row operations method to determine the unique solution.

10.2.1 The Gaussian Elimination Method for 3×3 Systems

- The Gaussian elimination method makes use of augmented matrices, elementary row operations and back substitution to solve a set of simultaneous equations.
- The equations are first rewritten as augmented matrices.

- For example:

$$\begin{aligned}x + y + z &= 1 \\x + 3y + 2z &= 2 \\2x - y + 2z &= -1\end{aligned}$$

Rewritten as an augmented matrix:

$$\left(\begin{array}{ccc|c} 1 & 1 & 1 & 1 \\ 1 & 3 & 2 & 2 \\ 2 & -1 & 2 & -1 \end{array} \right)$$

coefficients of x, y and z .

constants

- An augmented matrix in *echelon form* (*triangular form*) is one where all entries above or below any one of the diagonals in the coefficient part are zero.

- $$\left(\begin{array}{ccc|c} 1 & 2 & 3 & 10 \\ 0 & 2 & 1 & 5 \\ 0 & 0 & 1 & 3 \end{array} \right), \left(\begin{array}{ccc|c} 1 & 0 & 0 & 2 \\ 1 & 2 & 0 & 0 \\ 2 & 2 & 1 & 3 \end{array} \right), \left(\begin{array}{ccc|c} 0 & 0 & 3 & 2 \\ 0 & 2 & 1 & 0 \\ 1 & 2 & 1 & 3 \end{array} \right), \left(\begin{array}{ccc|c} 1 & 2 & 3 & 2 \\ 1 & 2 & 0 & 0 \\ 1 & 0 & 0 & 3 \end{array} \right)$$

are examples of augmented matrices in echelon/triangular form.

- An augmented matrix in echelon form permits the immediate retrieval of the value of one of the variables. Values for the remaining variables are then obtained by back substitution.

- Consider the augmented matrix in echelon form

$$\left(\begin{array}{ccc|c} 1 & 2 & 3 & 10 \\ 0 & 2 & 1 & 5 \\ 0 & 0 & 1 & 3 \end{array} \right)$$
 for a

system with variables x, y and z .

- The third line is equivalent to the equation $z = 3$.
We have an immediate solution for z .
- The second line is equivalent to $2y + z = 5$.
But $z = 3 \Rightarrow y = 1$.
- The first line is equivalent to $x + 2y + 3z = 10$
But $z = 3$ and $y = 1 \Rightarrow x = -1$.
- Hence, the solution to this system is $x = -1, y = 1$ and $z = 3$.

- $\left(\begin{array}{ccc|c} 1 & 0 & 0 & 2 \\ 0 & 1 & 0 & 0 \\ 0 & 0 & 1 & 3 \end{array}\right)$ is an augmented matrix in *reduced* echelon/triangular form.
 - All entries in a diagonal of the coefficient part are one and all other entries are zero.
 - It allows immediate reading of the solutions of the system. If the variables are x, y and z , then $x = 2, y = 0$ and $z = 3$.
- In summary, the Gaussian elimination method uses *elementary row operations* to reduce an augmented matrix into echelon form. This will allow the retrieval of an immediate solution. Back substitution is then used to determine the rest of the variables.
 - Row operations are similar to the “tweaking of pairs of equations” to eliminate a variable.
 - It is not always necessary to end with an augmented matrix in echelon form.

Example 10.1

Solve each of the following augmented matrices with variables x, y and z :

$$(a) \left(\begin{array}{ccc|c} 1 & 0 & 0 & 2 \\ 1 & 2 & 0 & 0 \\ 2 & 2 & 1 & 3 \end{array}\right) \quad (b) \left(\begin{array}{ccc|c} 0 & 0 & 3 & 3 \\ 0 & 2 & 1 & 1 \\ 1 & 2 & 1 & 3 \end{array}\right) \quad (c) \left(\begin{array}{ccc|c} 1 & 2 & -1 & 2 \\ 0 & 1 & 0 & 5 \\ 2 & -1 & 0 & 3 \end{array}\right)$$

Solution:

$$\begin{array}{ll} (a) \text{ From row 1:} & x = 2 \\ \text{From row 2:} & x + 2y = 0 \quad \Rightarrow y = -1 \\ \text{From row 3:} & 2x + 2y + z = 3 \quad \Rightarrow z = 1 \\ \text{Hence:} & x = 2, y = -1 \text{ and } z = 1 \end{array}$$

$$\begin{array}{ll} (b) \text{ From row 1:} & z = 1 \\ \text{From row 2:} & 2y + z = 1 \quad \Rightarrow y = 0 \\ \text{From row 3:} & x + 2y + z = 3 \quad \Rightarrow x = 2 \\ \text{Hence:} & x = 2, y = 0 \text{ and } z = 1 \end{array}$$

$$\begin{array}{ll} (c) \text{ From row 2:} & y = 5 \\ \text{From row 3:} & 2x - y = 3 \quad \Rightarrow x = 4 \\ \text{From row 1:} & x + 2y - z = 2 \quad \Rightarrow z = 12 \\ \text{Hence:} & x = 4, y = 5 \text{ and } z = 12 \end{array}$$

Example 10.2

Without the use of a calculator, use Gaussian elimination to solve for x , y and z in:

$$2x - y + 4z = 15$$

$$3x + 2y - z = 5$$

$$x + y + z = 4$$

Solution:

Gaussian Elimination	Algebraic Elimination
<p>Rewrite system as an augmented matrix with the third equation ahead of the rest:</p> $\left(\begin{array}{ccc c} 1 & 1 & 1 & 4 \\ 2 & -1 & 4 & 15 \\ 3 & 2 & -1 & 5 \end{array} \right)$	<p>Rewrite the equations as:</p> $\begin{array}{rcl} x + y + z = 4 & & \text{I} \\ 2x - y + 4z = 15 & & \text{II} \\ 3x + 2y - z = 5 & & \text{III} \end{array}$
<p>Apply row operations on Row 1 & Row 2 and Row 1 and Row 3:</p> $\begin{array}{l} 2R1-R2 \\ 3R1-R3 \end{array} \left(\begin{array}{ccc c} 1 & 1 & 1 & 4 \\ 0 & 3 & -2 & -7 \\ 0 & 1 & 4 & 7 \end{array} \right)$	<p>Eliminate x from I & II:</p> $\begin{array}{rcl} I \times 2 & 2x + 2y + 2z = 8 & \text{Ia} \\ Ia - II & 3y - 2z = -7 & \text{IV} \end{array}$
<p>Apply row operations on Row 2 & Row 3:</p> $\begin{array}{l} 2R1-R2 \\ 3R1-R3 \end{array} \left(\begin{array}{ccc c} 1 & 1 & 1 & 4 \\ 0 & 3 & -2 & -7 \\ 0 & 0 & 14 & 28 \end{array} \right)$	<p>Eliminate x from I & III:</p> $\begin{array}{rcl} I \times 3 & 3x + 3y + 3z = 12 & \text{Ib} \\ Ib - III & y + 4z = 7 & \text{V} \end{array}$
<p>From row 3, $14z = 28 \Rightarrow z = 2$ Substitute $z = 2$ into Row 2: $y = -1$ Substitute $z = 2, y = -1$ into Row 1: $x = 3$</p>	<p>Hence, equations are reduced to:</p> $\begin{array}{rcl} 3y - 2z = -7 & & \text{IV} \\ y + 4z = 7 & & \text{V} \end{array}$
<p>Hence, $x = 3, y = -1, z = 2$.</p>	<p>Eliminate y from IV & V:</p> $\begin{array}{rcl} V \times 3 & 3y + 12z = 21 & \text{Va} \\ Va - IV & 14z = 28 \\ & \Rightarrow z = 2 \end{array}$ <p>Substitute $z = 2$ into V:</p> $y = -1$ <p>Substitute $z = 2, y = -1$ into I:</p> $x = 3.$ <p>Hence, $x = 3, y = -1, z = 2$.</p>

Notes:

- As seen in the example above, the Gaussian elimination method is a “trimmed down” version of the method of algebraic elimination.
- The row operations applied are identical to the operations applied to the equations in the algebraic method.
- Where possible, rearrange the order of rows/equations so that the first coefficient (pivot element) is one. Conventionally, we wish to obtain a triangle of zeros at the bottom left.
 This is achieved by: (i) combining rows 1 and 2, (eliminate x from equations I & II)
 (ii) combining rows 1 and 3 (eliminate x from equations I & III)
 (iii) combining the “new” rows 2 and 3 (eliminate y from resulting equations).

Example 10.3

Without the use of a calculator, use row operations to solve:

$$\begin{aligned} 2x - y + 2z &= -1 \\ x + y + z &= 1 \\ x + 3y + 2z &= 2 \end{aligned}$$

Solution:

Rewrite the system as:

$$\begin{aligned} x + y + z &= 1 \\ x + 3y + 2z &= 2 \\ 2x - y + 2z &= -1 \end{aligned}$$

Rewrite as an augmented matrix:

$$\left(\begin{array}{ccc|c} 1 & 1 & 1 & 1 \\ 1 & 3 & 2 & 2 \\ 2 & -1 & 2 & -1 \end{array} \right)$$

Use row operations to create a lower triangle of zeros:

$$\begin{array}{l} R1 - R2 \rightarrow R2 \\ R1 \times 2 - R3 \rightarrow R3 \end{array} \quad \left(\begin{array}{ccc|c} 1 & 1 & 1 & 1 \\ 0 & -2 & -1 & -1 \\ 0 & 3 & 0 & 3 \end{array} \right) \quad [1]$$

$$R2 \times 3 + R3 \times 2 \rightarrow R3 \quad \left(\begin{array}{ccc|c} 1 & 1 & 1 & 1 \\ 0 & -2 & -1 & -1 \\ 0 & 0 & -3 & 3 \end{array} \right) \quad [2]$$

$$\begin{array}{l} \text{From row 3:} \quad -3z = 3 \quad \Rightarrow z = -1 \\ \text{From row 2:} \quad -2y - z = -1 \quad \Rightarrow y = 1 \\ \text{From row 1:} \quad x + y + z = 1 \quad \Rightarrow x = 1 \end{array}$$

Hence: $x = 1, y = 1, z = -1$

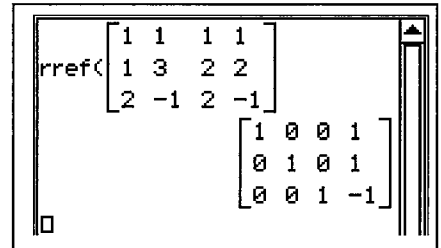

Notes:

- It is customary to rearrange the equations so that the element in the first row and first column (called the pivot element) is "one". The row operations are much simpler when the pivot is "one".
- The augmented matrix in [2] is in echelon form.
- However, notice that the augmented matrix in [1] is not in echelon form but yields an immediate solution and back substitution would be successful. As such, it would have been sufficient to stop at [1].
- Hence, if during the process of reducing an augmented matrix into echelon form, an immediate solution emerges and back substitution would be successful, it is no longer necessary to proceed to obtain an echelon form.
- The "rref" command available on CAS calculators, produces an augmented matrix in reduced echelon form. [rref: reduced row echelon form]

Exercise 10.1 This exercise is to be completed without the use of a calculator.1. Solve for x , y and z (in the usual positions) corresponding to the augmented matrices.

(a)
$$\left(\begin{array}{ccc|c} 1 & 3 & -\frac{1}{2} & 6 \\ 0 & 1 & 5 & 11 \\ 0 & 0 & 1 & 2 \end{array}\right)$$

(b)
$$\left(\begin{array}{ccc|c} 1 & -4 & 1 & -4 \\ 0 & 1 & \frac{1}{6} & \frac{5}{2} \\ 0 & 0 & 1 & 3 \end{array}\right)$$

(c)
$$\left(\begin{array}{ccc|c} 1 & \frac{1}{4} & \frac{1}{2} & 1 \\ 0 & 1 & 2 & 0 \\ 0 & 0 & 1 & -2 \end{array}\right)$$

(d)
$$\left(\begin{array}{ccc|c} 1 & 1 & \frac{1}{3} & 7 \\ 0 & 1 & \frac{1}{6} & \frac{10}{3} \\ 0 & 0 & 1 & 3 \end{array}\right)$$

(e)
$$\left(\begin{array}{ccc|c} 1 & 3 & 1 & 6 \\ 0 & 1 & 0 & 1 \\ 0 & 1 & 1 & 2 \end{array}\right)$$

(f)
$$\left(\begin{array}{ccc|c} 0 & 1 & 0 & -4 \\ 0 & 1 & 1 & 2 \\ 1 & 0 & 1 & 3 \end{array}\right)$$

(g)
$$\left(\begin{array}{ccc|c} 1 & 1 & 1 & 7 \\ 0 & 2 & 1 & 8 \\ 0 & 1 & 2 & 10 \end{array}\right)$$

(h)
$$\left(\begin{array}{ccc|c} 2 & 1 & 1 & -5 \\ 0 & -1 & 1 & -7 \\ 0 & 4 & -1 & 13 \end{array}\right)$$

(i)
$$\left(\begin{array}{ccc|c} 2 & 0 & 0 & -4 \\ 1 & -1 & 4 & -6 \\ 1 & 1 & -1 & 8 \end{array}\right)$$

2. Use elementary row operations to solve:

(a) $x + 2z = 7$

$2x + y = 16$

$-2y + 9z = -3$

(b) $2x + y = 0$

$x + 2z = 4$

$-2y + 9z = 19$

(c) $2x - y + 4z = 12$

$4x + y = 6$

$-3x + 2y + z = 4$

(d) $-3y - 4z = 1$

$3x - 4z = 4$

$-2y + 4x = 1$

3. Use Gaussian elimination to solve for x , y and z in:

(a) $2x + y + z = 7$, $3x + 2y - z = 15$ and $x - 2y + 2z = -8$

(b) $2x + 3y + 2z = 0$, $3x + 2y + 4z = 13$ and $x + y + z = 2$

(c) $x + y + z = 12$, $x - y + z = 3$ and $2x + 3y - 3z = 6$

(d) $x + y + 2z = 4$, $x + y - 2z = 3$ and $3x + 4y + 2z = 12$

4. Use an augmented matrix method to solve:

(a) $2x - y - z = 0$

$4x - y + 2z - 4 = 0$

$2x + 2y + z - 4 = 0$

(b) $2x + 5y = 180 - 6z$

$6x + z = 20 + 3y$

$5y - 2z = 45 - 7x$

(c) $2/x + 3/y - 1/z = -7$

$3/x + 2/y + 1/z = -3$

$5/x - 1/y + 3/z = 2$

(d) $-x^2 + 2y^2 + z^2 = 2$

$2x^2 - 2y^2 + 3z^2 = 5$

$3x^2 + y^2 - 5z^2 = 6$

5. Use the method of elimination to solve:

(a) $x + y + z = -1$

$x + 2y + z = 1$

$2x + y + z = 0$

$x + y + 2z = -5$

(b) $x + 2y + 3z = 1$

$2x + y - 3z = -9$

$x + 3y + z = -7$

$3x + y - z = -7$

Example 10.4

When Wayne emptied his coin wallet, he counted a total of 23 fifty cents, twenty cents and ten cents coins. The number of fifty cents and twenty cents coins was three more than the number of ten cents coins. The total value of these coins came to \$5.10. Use Gaussian elimination to find the number of fifty cents, twenty cents and ten cents coins in Wayne's wallet.

Solution:

Let x : No. of fifty cents coins, y : No. of twenty cents coins, z : No. of ten cents coins.

$$\begin{aligned}x + y + z &= 23 \\x + y - z &= 3 \\50x + 20y + 10z &= 510\end{aligned}$$

Rewrite as an augmented matrix:
$$\left(\begin{array}{ccc|c} 1 & 1 & 1 & 23 \\ 1 & 1 & -1 & 3 \\ 50 & 20 & 10 & 510 \end{array} \right)$$

Use row operations to create a lower triangle of zeros:

$$\begin{array}{l} R1 - R2 \rightarrow R2 \\ R3 - 20 \times R1 \rightarrow R3 \end{array} \left(\begin{array}{ccc|c} 1 & 1 & 1 & 23 \\ 0 & 0 & 2 & 20 \\ 30 & 0 & -10 & 50 \end{array} \right)$$

$$\begin{array}{lll} \text{From row 2:} & 2z = 20 & \Rightarrow z = 10 \\ \text{From row 3:} & 30x - 10z = 50 & \Rightarrow x = 5 \\ \text{From row 1:} & x + y + z = 23 & \Rightarrow y = 8 \end{array}$$

Hence: $x = 5, y = 8$ and $z = 10$.

Exercise 10.2

1. A fast food restaurant offers three types of happy meals; A, B and C. The Jack family buys four A meals, one B meal and two C meals for \$36.50. The Mack family buys one A, three B and one C meals for \$23.10. The King family buys two A, two B and five C meals for \$50.10. Use your calculator and the method of Gaussian elimination to find the cost of each of these types of happy meals.
2. A builder uses three types of windows A, B and C. For model home P, he uses 6 type A, 2 type B and 1 type C windows. The corresponding numbers for model homes Q and R are 2, 6 and 3 and 3, 4 and 4 respectively. In a certain year, the builder used 157 type A, 166 type B and 109 type C windows. Given that these are the only types of houses he builds, use your calculator and the method of Gaussian elimination to find how many of each type of home he built.

3. ComputerWest assembles and sells 3 versions of a Notebook computer. Version A requires 3 pieces of component P, 5 pieces of component Q and 7 pieces of component R. The corresponding numbers for version B and C are respectively, 1, 1, 1 and 4, 8, 16. In December 2015, 790, 1 410 and 2 510 pieces of component P, Q and R respectively were used. Use your calculator and the method of Gaussian elimination to find how many of each version of machines was assembled that month.
4. Helen, Catherine and Frances bought tickets for three separate events. The table below shows the number of tickets bought by each person.

	Helen	Catherine	Frances
NBL Final	3	2	1
AFL Final	2	3	5
Concert	5	1	4

If the total cost for Helen, Catherine and Frances were \$267, \$145 and \$230 respectively, use your calculator and the method of Gaussian elimination to find the cost for each of these events.

5. A fish of species P each day consumes 8g of food A, 5g of food B and 3g of food C. A fish of species Q each day consumes 5g of food A, 3g of food B and 2g of food C. A fish of species R consumes 3g, 1g and 1g respectively of food A, B and C. If a given environment has 310g of food A, 170g of food B and 115g of food C, use your calculator and the method of Gaussian elimination to find the population size of each of the three species that will consume exactly all of the available food in: (a) one day (b) five days.
6. A supermarket sells 3 types of Christmas hampers during the Christmas season. Hamper A has no wine and 2 cans of beer and twice as many cans of cool drinks as cans of beer. Hamper B has 6 cans of cool drink and an equal number of cans of beer and half as many bottles of wine as there are cans of beer. Hamper C has 4 cans of cool drinks, 2 bottles of wine and as many cans of beer as there are cans of cool drinks and bottles of wine combined. A worker who prepares the hampers makes use of 202 cans of cool drinks, 218 cans of beer and 81 bottles of wine. Use your calculator and the method of Gaussian elimination to find the number of each type of hamper that the worker made up.
7. The diagram below shows the volume of traffic flow (in vehicles per hour) through an intersection between 7.30 am and 8.30 am on a weekday. Assume that no cars are stalled at the intersection. Use your calculator and the method of Gaussian elimination to find the values of x , y and z .

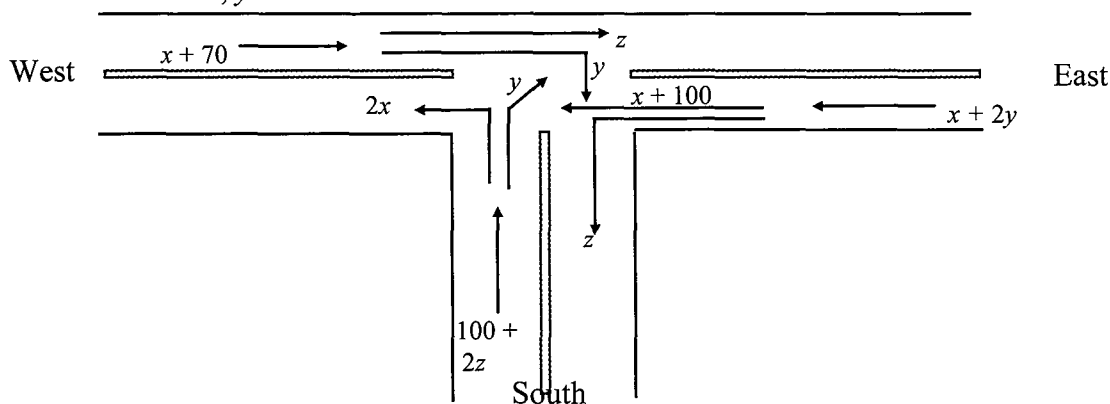

8. The schematic diagram below shows the volume of passengers (in tens of thousands) through the airports, A, B, C, D, E, F and G in a certain month. Without the use of a calculator, find the values of x , y and z if there are 10 000 more arrivals than departures at C, 20 000 more departures than arrivals at D and an equal number of arrivals and departures at E.

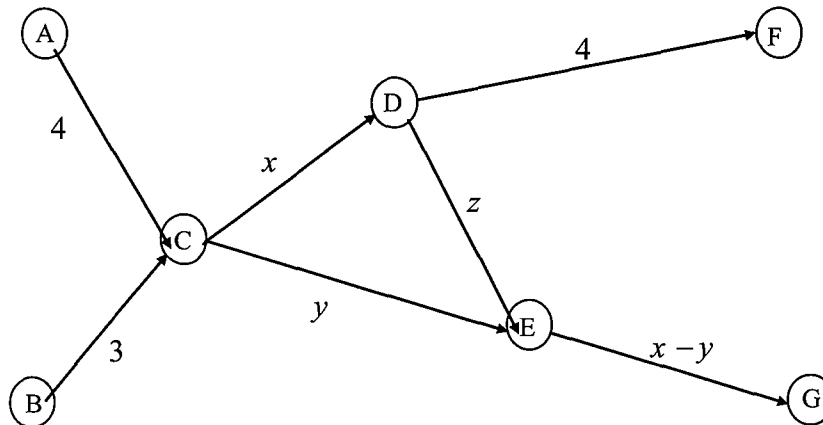

9. A certain protected mammal has a maximum life span of 10 years. Let x_1 , x_2 and x_3 be the numbers of the mammal in each of the age groups 0 – 1 years, 2 – 8 years and 9 – 10 years respectively, and y_1 , y_2 and y_3 be the corresponding numbers after one calendar year. The numbers x_1 , x_2 , x_3 , y_1 , y_2 , and y_3 satisfy the equations:

$$0.05x_1 + 0.75x_2 + 0.2x_3 = y_1$$

$$0.85x_1 + 0.99x_2 = y_2$$

$$0.2x_2 = y_3$$

If at the start of 2015, there were 1 340, 2 108 and 340 in the corresponding age groups, use your calculator and an elimination method to find the corresponding numbers in each age group at the start of 2014.

10. A toy manufacturer markets building bricks in 3 packs. Pack B contains twice as many red bricks as Pack A and Pack C contains 5 times as many red bricks as Pack A. There are twice as many blue bricks as red and white bricks combined in the 30 bricks contained in Pack A. There are 4 times as many white bricks as red bricks in Pack A. The ratio of the red to white to blue bricks for Packs B and C are 2 : 8 : 15 and 1 : 3 : 5 respectively.
- Describe the composition of bricks in Pack A.
 - Use your calculator and the method of Gaussian elimination to find the number of units of each of the different Packs that will fully utilise a stock of 11 990 red bricks, 40 460 white bricks and 76 200 blue bricks.

*11. A minipak consists of 2 chocolate eclairs, 1 mintie and 2 lollipops. A midipak consists of 3 chocolate eclairs, 1 mintie and 7 lollipops. A maxipak consists of 5 chocolate eclairs, 2 minties and n lollipops. Jane had 94 chocolate eclairs, 38 minties and 166 lollipops. Use your calculator and the method of Gaussian elimination to find the value of n so that each and every type of sweet available is used up. The composition of each pack is as stated.

*12. The diagram below shows the flow (in litres/hour) of fluid through a network of pipes. The numbers or letters indicate the flow rate through the pipe concerned. Assume that no fluid is lost in the process.

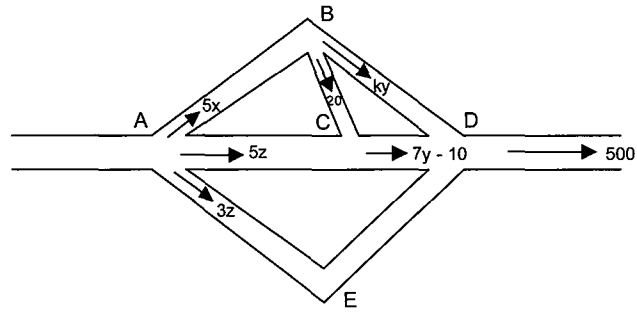

(a) Find the values of x , y and z when $k = 2$.

(b) Comment on the flow network when $k < 0$.

(c) Find the value of k for which the network flow as indicated becomes impossible.

13. Given $\mathbf{a} = \langle 1, -1, 1 \rangle$ and $\mathbf{a} \times \mathbf{b} = \langle 1, 4, 3 \rangle$, use Gaussian elimination to find \mathbf{b} .

14. Given $\mathbf{b} = \langle 2, 1, 1 \rangle$ and $\mathbf{a} \times \mathbf{b} = \langle 6, -13, 1 \rangle$, use Gaussian elimination to find \mathbf{a} .

10.3 Existence of Solutions for 3×3 Systems

- At the start of this chapter, it was mentioned that a 3×3 system can either have:
 - a unique set of solutions
 - an infinite set of solutions
 - no solutions at all.
- In this section, we will explore in greater detail the conditions that cause 3×3 systems to be divided into these three possibilities.

- Consider the following cases.

Unique Set of Solutions

Consider $\left(\begin{array}{ccc|c} 1 & 1 & 1 & 2 \\ 1 & 1 & 2 & 3 \\ 2 & 3 & 2 & 4 \end{array}\right)$ which reduces to $\left(\begin{array}{ccc|c} 1 & 0 & 0 & 1 \\ 0 & 1 & 0 & 0 \\ 0 & 0 & 1 & 1 \end{array}\right)$.

- This set has a unique set of solutions.
- All three equations are different and form a non-contradictory consistent set.
- The three planes meet at a common point.

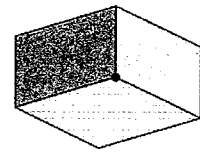

```

rref<
[ 1 1 1 2 ]
[ 1 1 2 3 ]
[ 2 3 2 4 ]
[ 1 0 0 1 ]
[ 0 1 0 0 ]
[ 0 0 1 1 ]
    
```

Infinite Number of Solutions

Consider $\left(\begin{array}{ccc|c} 1 & 1 & 1 & 2 \\ 1 & 1 & 1 & 2 \\ 1 & 1 & 1 & 2 \end{array}\right)$, $\left(\begin{array}{ccc|c} 1 & 1 & 1 & 2 \\ 1 & 1 & 1 & 2 \\ 2 & 3 & 2 & 4 \end{array}\right)$ and $\left(\begin{array}{ccc|c} 1 & 1 & 1 & 2 \\ 1 & 1 & 2 & 3 \\ 3 & 3 & 5 & 8 \end{array}\right)$

which reduces to $\left(\begin{array}{ccc|c} 1 & 1 & 1 & 2 \\ 0 & 0 & 0 & 0 \\ 0 & 0 & 0 & 0 \end{array}\right)$, $\left(\begin{array}{ccc|c} 1 & 0 & 1 & 2 \\ 0 & 1 & 0 & 0 \\ 0 & 0 & 0 & 0 \end{array}\right)$ and

$\left(\begin{array}{ccc|c} 1 & 1 & 0 & 1 \\ 0 & 0 & 1 & 1 \\ 0 & 0 & 0 & 0 \end{array}\right)$ respectively.

- Note that in each instance, each term in the third row of the reduced augmented matrices is zero.
 - This means there is insufficient information to determine a unique set of solutions.
 - Hence, these systems have an infinite number of solutions.
- The first set consists of three identical rows.
 - There is actually only one distinct plane.
 - Hence, there are an infinite number of points of contact.
- The second set consists of two identical rows and a non-contradictory third row.
 - There are actually only two distinct planes.
 - These planes meet along a common line.
 - Hence, there are an infinite number of points of contact.
- The third set consists of three rows but the third row is a linear combination of the first two rows ($R_3 = R_1 + 2 \times R_2$).
 - These 3 planes meet along a common line.
 - Hence, there are an infinite number of points of contact.

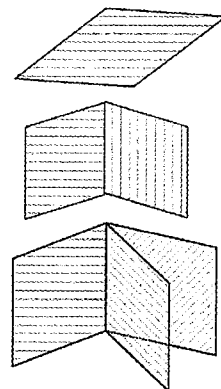

```

rref<
[ 1 1 1 2 ]
[ 1 1 1 2 ]
[ 1 1 1 2 ]
[ 1 1 1 2 ]
[ 0 0 0 0 ]
[ 0 0 0 0 ]
rref<
[ 1 1 1 2 ]
[ 1 1 1 2 ]
[ 2 3 2 4 ]
[ 1 1 1 2 ]
[ 0 0 0 0 ]
[ 1 0 1 2 ]
[ 0 1 0 0 ]
[ 0 0 0 0 ]
rref<
[ 1 1 1 2 ]
[ 1 1 2 3 ]
[ 3 3 5 8 ]
[ 1 1 0 1 ]
[ 0 0 1 1 ]
[ 0 0 0 0 ]
    
```

No Solution

Consider $\begin{pmatrix} 1 & 1 & 1 & | & 2 \\ 1 & 1 & 1 & | & 3 \\ 1 & 1 & 1 & | & 4 \end{pmatrix}$, $\begin{pmatrix} 1 & 1 & 1 & | & 2 \\ 1 & 1 & 1 & | & 2 \\ 1 & 1 & 1 & | & 3 \end{pmatrix}$, $\begin{pmatrix} 1 & 1 & 1 & | & 2 \\ 1 & 1 & 1 & | & 3 \\ 1 & 2 & 1 & | & 3 \end{pmatrix}$ and

$\begin{pmatrix} 1 & 1 & 1 & | & 2 \\ 1 & 1 & 2 & | & 3 \\ 2 & 2 & 3 & | & 6 \end{pmatrix}$ which reduces to $\begin{pmatrix} 1 & 1 & 1 & | & 0 \\ 0 & 0 & 0 & | & 1 \\ 0 & 0 & 0 & | & 0 \end{pmatrix}$,

$\begin{pmatrix} 1 & 1 & 1 & | & 0 \\ 0 & 0 & 0 & | & 1 \\ 0 & 0 & 0 & | & 0 \end{pmatrix}$, $\begin{pmatrix} 1 & 0 & 1 & | & 0 \\ 0 & 1 & 0 & | & 0 \\ 0 & 0 & 0 & | & 1 \end{pmatrix}$ and $\begin{pmatrix} 1 & 1 & 0 & | & 1 \\ 0 & 0 & 0 & | & 1 \\ 0 & 0 & 0 & | & 1 \end{pmatrix}$

respectively.

- In the reduced matrices, note that in each instance, there is one row that is contradictory: R2, R2, R3 and R3 in sets 1, 2, 3, and 4 respectively. Each of these rows imply that $0 = 1$.
 - Hence, these systems have no solutions.
- The first set consists of three “contradictory” rows.
 - The three planes are all parallel.
 - Hence, these planes do not intersect.
- The second set consists of two identical rows and a third row that “contradicts” the first two.
 - There are actually only two distinct parallel planes.
 - Hence, these planes do not intersect.
- The third set consists of two contradictory rows (R1 & R2) and a third consistent row.
 - There are two parallel planes and a third plane.
 - Hence, the first two planes do not intersect. But the third intersects the first two and hence, there is no common point/line of intersection between these planes.
- The fourth set consists of two consistent rows but the third row “contradicts” a linear combination of the first two rows ($R3 \neq R1 + R2$).
 - These three planes will meet to form a prism.
 - Hence, these planes do not intersect.

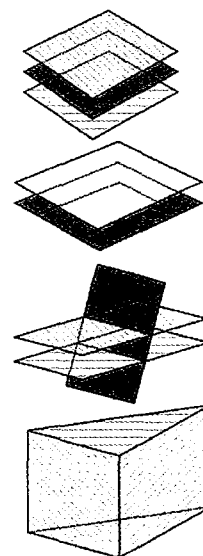

rref($\begin{bmatrix} 1 & 1 & 1 & 2 \\ 1 & 1 & 1 & 3 \\ 1 & 1 & 1 & 4 \end{bmatrix}$)	$\begin{bmatrix} 1 & 1 & 1 & 0 \\ 0 & 0 & 0 & 1 \\ 0 & 0 & 0 & 0 \end{bmatrix}$
rref($\begin{bmatrix} 1 & 1 & 1 & 2 \\ 1 & 1 & 1 & 2 \\ 1 & 1 & 1 & 3 \end{bmatrix}$)	$\begin{bmatrix} 1 & 1 & 1 & 0 \\ 0 & 0 & 0 & 1 \\ 0 & 0 & 0 & 0 \end{bmatrix}$
rref($\begin{bmatrix} 1 & 1 & 1 & 2 \\ 1 & 1 & 1 & 3 \\ 1 & 2 & 1 & 3 \end{bmatrix}$)	$\begin{bmatrix} 1 & 0 & 1 & 0 \\ 0 & 1 & 0 & 0 \\ 0 & 0 & 0 & 1 \end{bmatrix}$
rref($\begin{bmatrix} 1 & 1 & 1 & 2 \\ 1 & 1 & 2 & 3 \\ 2 & 2 & 3 & 6 \end{bmatrix}$)	$\begin{bmatrix} 1 & 1 & 0 & 0 \\ 0 & 0 & 1 & 0 \\ 0 & 0 & 0 & 1 \end{bmatrix}$

- In summary,

consider the augmented matrix in echelon form: $\left(\begin{array}{ccc|c} 2 & 3 & 4 & 9 \\ 0 & 1 & 4 & 5 \\ 0 & 0 & p & q \end{array} \right)$

- If $p \neq 0$, then the system has a unique set of solutions.
 - If $p = 0$ and $q = 0$, then the system has an infinite number of solutions.
 - If $p = 0$ and $q \neq 0$, then the system has no solution.
- If any of the equations are multiples of each other, or the equations are linear combinations of each other, then the system has an infinite number of solutions.
 - If the coefficient parts of any two equations are multiples or linear combinations of each other but “contradict” in the accompanying constants, then the system has no solution.
 - For example:
 - $x + y + z = 1$ and $2x + 2y + 2z = 1$.
The coefficients in the second equation are each twice those of the first equation, but the constant in the second equation is not twice the constant in the first equation.
 - $x + y + z = 1$, $x + 2y + 3z = 4$ and $2x + 3y + 4z = 8$.
The LHS of the third equation is the sum of the first two equations but the right hand side is not.

Example 10.5

For the augmented matrix $\left(\begin{array}{ccc|c} 1 & -1 & 1 & 5 \\ 0 & 1 & 5 & 6 \\ 0 & 0 & (p-1)(p+2) & p+2 \end{array} \right)$,

find the value(s) for p so that the given system has:

- (a) a unique set of solution (b) no solution (c) an infinite number of solutions.

Solution:

- (a) For a unique set of solutions: $(p - 1)(p + 2) \neq 0$
Hence: $p \neq 1$ and $p \neq -2, p \in \mathbb{R}$.
- (b) For no solution: $(p - 1)(p + 2) = 0$ and $p + 2 \neq 0$
Hence: $p = 1$.
- (c) For an infinite number of solutions: $(p - 1)(p + 2) = 0$ and $p + 2 = 0$
Hence: $p = -2$.

Example 10.6

For the augmented matrix $\left(\begin{array}{ccc|c} 1 & -1 & 1 & 4 \\ 0 & 1 & 1 & -3 \\ 0 & 0 & p^2-1 & q-2 \end{array} \right)$,

find the value(s) for p and q so that the given system has:

(a) a unique set of solution (b) no solution (c) an infinite number of solutions.

Solution:

(a) For a unique set of solutions: $p^2 - 1 \neq 0$ with $q \in \mathbb{R}$
 Hence: $p \neq 1$ and $p \neq -1$, $p \in \mathbb{R}$ with $q \in \mathbb{R}$

(b) For no solution: $p^2 - 1 = 0$ with $q - 2 \neq 0$
 Hence: $p = \pm 1$ with $q \neq 2$, $q \in \mathbb{R}$.

(c) For an infinite number of solutions: $p^2 - 1 = 0$ with $q - 2 = 0$
 Hence: $p = \pm 1$ with $q = 2$.

Example 10.7

Consider $x + y + z = 3$, $x - 2y + z = 6$, $x - y + kz = m$

Find the value(s) of k and m so that the given system has:

(a) a unique set of solution (b) more than one solution (c) no solution.

Find the solutions (in terms of k and m) in (a) and (b).

Solution:

Augmented matrix: $\left(\begin{array}{ccc|c} 1 & 1 & 1 & 3 \\ 1 & -2 & 1 & 6 \\ 1 & -1 & k & m \end{array} \right)$

Using elementary row operations: $R_1 - R_2 \rightarrow R_2$
 $R_1 - R_3 \rightarrow R_3$ $\left(\begin{array}{ccc|c} 1 & 1 & 1 & 3 \\ 0 & 3 & 0 & -3 \\ 0 & 2 & 1-k & 3-m \end{array} \right)$

$R_2 \times 2 - R_3 \times 3 \rightarrow R_3$ $\left(\begin{array}{ccc|c} 1 & 1 & 1 & 3 \\ 0 & 3 & 0 & -3 \\ 0 & 0 & -3(1-k) & 3(m-5) \end{array} \right)$

(a) For a unique set of solutions: $k \neq 1$ and $m \in \mathbb{R}$

From row 2: $3y = -3 \Rightarrow y = -1$.

From row 3: $-3(1-k)z = 3(m-5) \Rightarrow z = \frac{m-5}{k-1}$

From row 1: $x + (-1) + \frac{m-5}{k-1} = 3 \Rightarrow x = \frac{m-5}{1-k} + 4$

- (b) For more than one solution: $k = 1$ with $m = 5$.
 From row 2: $y = -1$.
 From row 1: $x - 1 + z = 3 \Rightarrow x + z = 4$
 $z = 4 - x$.
 Hence solutions are of the form: $x = t, y = -1, z = 4 - t, t \in \mathbb{R}$.
- (c) For no solutions: $k = 1$ and $m \neq 5, m \in \mathbb{R}$.

Notes:

- The infinite set of solutions in (b) is described in parametric form.
 This represents the parametric equation of the common line of intersection.
 The equivalent Cartesian equation of this line is $x = 4 - z, y = -1$.

Exercise 10.3

1. Explain why the following sets of simultaneous equations have no solutions:

- | | |
|-----------------------|------------------------|
| (a) $x + y + z = 2$ | (b) $2x + y - z = -2$ |
| $2x + 2y + 2z = -4$ | $x + 2y + z = 0$ |
| $x + 2y + z = 2$ | $3x + 3y = -1$ |
| (c) $x - y + 3z = 18$ | (d) $-x + y - 2z = -3$ |
| $-x + y - 3z = 15$ | $4x + 2y - 6z = 16$ |
| $2x + y + z = -2$ | $5x + y - 4z = 8$ |

2. Explain why the following sets of simultaneous equations have more than one solution:

- | | |
|-----------------------|------------------------|
| (a) $x - y + z = 5$ | (b) $x + 2y + 3z = 4$ |
| $2x - 2y + 2z = 10$ | $x + 2y - z = 0$ |
| $x - 2y + z = 8$ | $z = 1$ |
| (c) $x + 2y - 3z = 1$ | (d) $-x + y - 2z = -3$ |
| $-x + y + z = 1$ | $4x + 2y - 6z = 16$ |
| $x + 5y - 5z = 3$ | $5x + y - 4z = 19$ |

3. Find the value(s) of the unknowns for each of the following systems to have

(i) a unique set of solution, (ii) no solution and (iii) an infinite number of solutions.

- | | |
|---|---|
| (a) $\left(\begin{array}{ccc c} 1 & 1 & 1 & 7 \\ 0 & 1 & 2 & 5 \\ 0 & 0 & p & q-1 \end{array} \right)$ | (b) $\left(\begin{array}{ccc c} 1 & 1 & 1 & 7 \\ 0 & 1 & 2 & 5 \\ 0 & 0 & 3-p & 2q-1 \end{array} \right)$ |
| (c) $\left(\begin{array}{ccc c} 1 & 1 & 1 & 7 \\ 0 & 0 & p+1 & 5 \\ 0 & 1 & 2 & -1 \end{array} \right)$ | (d) $\left(\begin{array}{ccc c} 1 & 1 & 2 & 7 \\ 0 & 1 & -1 & 5 \\ 0 & 0 & (p-1)(p+2) & q-1 \end{array} \right)$ |
| (e) $\left(\begin{array}{ccc c} 1 & 2 & 1 & 10 \\ 0 & 1 & 3 & 4 \\ 0 & 0 & (p+1)(p+2) & p+2 \end{array} \right)$ | (f) $\left(\begin{array}{ccc c} 1 & 4 & 1 & 5 \\ 0 & -1 & -2 & 3 \\ 0 & 0 & p-3 & p^2-9 \end{array} \right)$ |

4. Find the value(s) of k so that each of the following systems have

(i) no solution (ii) a unique set of solution and (iii) more than one solution.

Find the solutions in (ii) and (iii).

(a) $x - 7y + 5z = 3$

$$x - y + 3z = -1$$

$$3y - z = k$$

(c) $5x + 2y + 3z = 4$

$$2x - 3y - z = 1$$

$$11x - ky = k$$

(b) $2x - y + z = 7$

$$3x - 5y + kz = 16$$

$$x - 4y + 3z = 9$$

(d) $x + 3y + 4z = 4$

$$2x + y + 3z = 3$$

$$5x - 10y - 5z = k$$

5. For what values of k does the system, $x + 11y + 2z = 0$, $x + 2ky + z = 0$, $kx + y + z = 0$ have solutions other than $x = y = z = 0$.

6. Consider the system of equations: $x + y + z = 8$, $2x + y - z = -5$ and $3x - y + kz = 3$.

The augmented matrix for this system of equations is reduced to $\left(\begin{array}{ccc|c} 1 & 1 & 1 & 8 \\ 0 & 1 & 3 & 21 \\ 0 & 0 & a+bk & 63 \end{array} \right)$. Find

the values of a and b .

7. Consider the system of equations:

$$x + 3y + z = 16$$

$$x + 4y = -3z + 23$$

$$x = 19 - 2y - 4z$$

$$x + 5y + 3z = p$$

(a) Write the augmented matrix for this system of equations.

(b) Reduce the augmented matrix into the form $\left(\begin{array}{ccc|c} \# & \# & \# & \# \\ 0 & \# & \# & \# \\ 0 & 0 & \# & \# \\ 0 & 0 & \# & \# \end{array} \right)$.

(c) Hence find the value of p for which the system has a unique set of solutions.

8. The augmented matrix for a system of equations is $\left(\begin{array}{cccc|c} 1 & -1 & 2 & 3 & 2 \\ 0 & 1 & 2 & -1 & 3 \\ 0 & 0 & 4 & 1 & 5 \\ 0 & 0 & 0 & (k-1)(k+2) & k^2+3k+2 \end{array} \right)$.

Find the value of k if the system:

(a) has no solutions (b) more than one solution (c) a unique set of solution.

Find the solutions in (b) and (c).

9. The augmented matrix for $\begin{pmatrix} 1 & -1 & 0 \\ 0 & 2 & -1 \\ 1 & 0 & 1 \end{pmatrix} \begin{pmatrix} a & b & c \\ d & e & f \\ g & h & i \end{pmatrix} = \begin{pmatrix} 1 & 0 & 0 \\ 0 & 1 & 0 \\ 0 & 0 & 1 \end{pmatrix}$ is $\left(\begin{array}{ccc|ccc} 1 & -1 & 0 & 1 & 0 & 0 \\ 0 & 2 & -1 & 0 & 1 & 0 \\ 1 & 0 & 1 & 0 & 0 & 1 \end{array} \right)$.

Use row operations to reduce the augmented matrix to $\left(\begin{array}{ccc|ccc} 1 & 0 & 0 & a & b & c \\ 0 & 1 & 0 & d & e & f \\ 0 & 0 & 1 & g & h & i \end{array} \right)$.

Hence, find $\begin{pmatrix} 1 & -1 & 0 \\ 0 & 2 & -1 \\ 1 & 0 & 1 \end{pmatrix}^{-1}$.

11 Differentiation

11.1 Review of Rules of Differentiation

- In this section we will review the rules of differentiation as covered in Mathematics Methods Units 1 & 2 and Mathematics Methods Units 3 & 4.
- The table below lists the derivatives for several commonly used functions.

Function	Derivative
x^n	$n x^{n-1}$
$e^{f(x)}$	$f'(x) e^{f(x)}$
$\ln f(x)$	$\frac{f'(x)}{f(x)}$
$\sin x$	$\cos x$
$\cos x$	$-\sin x$
$\tan x$	$\sec^2 x$
$\cot x$	$-\operatorname{cosec}^2 x$

- The table below lists the rules for differentiation.

Linear Rule	For $u = u(x)$, $v = v(x)$ and constants a and b : $\frac{d}{dx}[au + bv] = a \frac{du}{dx} + b \frac{dv}{dx}$
The Chain Rule	For $u = u(x)$: $\frac{d}{dx} f(u) = \frac{d}{du} f(u) \times \frac{du}{dx}$
The Product Rule	For $u = u(x)$ and $v = v(x)$: $\frac{d}{dx}(uv) = u \frac{dv}{dx} + v \frac{du}{dx}$
The Quotient Rule	For $u = u(x)$ and $v = v(x)$: $\frac{d}{dx} \left[\frac{u}{v} \right] = \frac{v \frac{du}{dx} - u \frac{dv}{dx}}{v^2}$

Example 11.1

Without the use of a calculator, find $\frac{dy}{dx}$ for each of the following:

(a) $y = \sqrt{1+e^{2x}}$ (b) $y = (1-2x)^3 \sin^2 \pi x$ (c) $y = \frac{\tan(1-2x)}{1+x^2}$ (d) $y = 10^{\cos x}$

Solution:

(a) $y = \sqrt{1+e^{2x}} = (1+e^{2x})^{\frac{1}{2}}$

Using the Chain Rule $\frac{dy}{dx} = \frac{1}{2} \times (1+e^{2x})^{-\frac{1}{2}} \times 2e^{2x}$

$$= \frac{e^{2x}}{\sqrt{1+e^{2x}}}$$

(b) $y = (1-2x)^3 \sin^2 \pi x$

Using the Product and Chain Rules:

$$\begin{aligned} \frac{dy}{dx} &= 3(1-2x)^2 \cdot (-2) \times \sin^2 \pi x + (1-2x)^3 \times 2 \sin \pi x \cos \pi x \times \pi \\ &= -6(1-2x)^2 \sin^2 \pi x + \pi (1-2x)^3 \sin 2\pi x \end{aligned}$$

(c) $\frac{\tan(1-2x)}{1+x^2}$

Using the quotient rule:

$$\begin{aligned} \frac{dy}{dx} &= \frac{(1+x^2) \times (-2 \sec^2(1-2x)) - (2x) \tan(1-2x)}{(1+x^2)^2} \\ &= \frac{-2(1+x^2) \sec^2(1-2x) - 2x \tan(1-2x)}{(1+x^2)^2} \end{aligned}$$

(d) $y = 10^{\cos x}$

Rewrite as: $y = e^{\ln 10^{\cos x}}$

$$= e^{\cos x \ln 10}$$

Hence: $\frac{dy}{dx} = -\ln 10 \sin x e^{\cos x \ln 10}$

$$= -\ln 10 \sin x 10^{\cos x}.$$

Example 11.2

Without the use of a CAS calculator, find $\frac{dy}{dx}$ if:

$$(a) y = \ln(1 - e^{-x})^4 \quad (b) y = \frac{\ln(1+x^2)}{1-x^2} \quad (c) y = \ln(x \sin x) \quad (d) y = \ln \sqrt{\frac{(1+x)}{(1-x)}}$$

Solution:

$$(a) y = \ln(1 - e^{-x})^4 \Rightarrow y = 4 \ln(1 - e^{-x})$$

$$\text{Hence:} \quad \frac{dy}{dx} = \frac{4e^{-x}}{1 - e^{-x}}$$

$$(b) y = \frac{\ln(1+x^2)}{1-x^2}$$

Using the quotient rule:

$$\begin{aligned} \frac{dy}{dx} &= \frac{(1-x^2) \left(\frac{2x}{1+x^2} \right) - (-2x) \ln(1+x^2)}{(1-x^2)^2} \\ &= \frac{2x(1-x^2) + 2x(1+x^2) \ln(1+x^2)}{(1+x^2)(1-x^2)^2} \\ &= \frac{2x[1-x^2 + (1+x^2) \ln(1+x^2)]}{(1+x^2)(1-x^2)^2} \end{aligned}$$

$$(c) y = \ln(x \sin x) \Rightarrow y = \ln x + \ln \sin x$$

$$\begin{aligned} \text{Hence:} \quad \frac{dy}{dx} &= \frac{1}{x} + \frac{\cos x}{\sin x} \\ &= \frac{1}{x} + \cot x \end{aligned}$$

$$(d) y = \ln \sqrt{\frac{(1+x)}{(1-x)}} \Rightarrow y = \frac{1}{2} \ln(1+x) - \frac{1}{2} \ln(1-x)$$

$$\begin{aligned} \frac{dy}{dx} &= \frac{1}{2(1+x)} - \frac{-1}{2(1-x)} \\ &= \frac{1}{(1+x)(1-x)} \end{aligned}$$

Example 11.3

Given that $y = \cos^2 x$, prove that $\frac{d^2y}{dx^2} + 4y = 2$.

Solution:

$$y = \cos^2 x$$

Differentiate with respect to x :

$$\begin{aligned}\frac{dy}{dx} &= 2 \cos x \times (-\sin x) \\ &= -2 \sin(x) \cos(x) \\ &= -\sin 2x\end{aligned}$$

Differentiate again:

$$\frac{d^2y}{dx^2} = -2 \cos 2x$$

Left Hand Side of Expression:

$$\begin{aligned}\frac{d^2y}{dx^2} + 4y &= -2 \cos 2x + 4 \cos^2 x \\ &= -2(2\cos^2 x - 1) + 4 \cos^2 x = 2\end{aligned}$$

Hence, $\frac{d^2y}{dx^2} + 4y = 2$.

Trigonometric Identities
• $\sin^2 x + \cos^2 x = 1$
• $\sec^2 x = 1 + \tan^2 x$
• $\operatorname{cosec}^2 x = 1 + \cot^2 x$
• $\sin 2x = 2 \sin x \cos x$
• $\cos 2x = \cos^2 x - \sin^2 x$
$ = 2 \cos^2 x - 1$
$ = 1 - 2 \sin^2 x$

Exercise 11.1 *To be completed without the use of a calculator.*

1. Differentiate each of the following expressions with respect to x :

(a) $(1 - \sqrt{x})^4$

(b) $\sqrt{1 - 2e^{-x}}$

(c) $(\sin x + \cos 2x)^2$

(d) $\sqrt{1 + \ln(1+x)}$

(e) $e^{-\tan x}$

(f) $\sin^2(1 + \pi x)$

(g) $\ln(1 + \cos \pi x)$

(h) $e^{-(x-1)^2}$

(i) $\ln(1 - x^2)^4$

(j) $\cot(1 + \sqrt{x})$

(k) $\sec e^{1+x}$

(l) 2^{1+x^2}

2. Differentiate each of the following expressions with respect to x :

(a) $x^2 \sin \omega x$

(b) $\sqrt{x} e^{\cot x}$

(c) $(1 + 2x)^2 \tan \omega x^2$

(d) $e^{(x+1)^2} \ln(\cos^2 x)$

(e) $e^{-\cos x} \sin^2 \pi x$

(f) $\cos 2x \sin^2 x$

(g) $\ln(x \tan x)$

(h) $e^{-x^2} \ln(xe^{2x})$

(i) $x^2 \ln \sqrt{1+e^x}$

(j) $\ln \left(\frac{x^2}{1+x} \right)$

(k) $e^{1+x} \ln \left(\frac{2x}{1-x} \right)$

(l) $x^2 \ln \left(\frac{x e^{-2x}}{(1+x)^2} \right)$

3. Differentiate each of the following expressions with respect to x :

(a) $\frac{1+x^2}{1-2x}$

(b) $\frac{\sqrt{x}}{1+\sqrt{x}}$

(c) $\frac{\sin 2x}{1+\cos 2x}$

(d) $\frac{e^{2x}}{1+e^{-2x}}$

(e) $\frac{e^{-2\cos x}}{1-2e^{\sin x}}$

(f) $\frac{\ln\sqrt{1+2x}}{1+2x}$

(g) $\frac{x^2}{\ln(1+e^{2x})}$

(h) $\frac{e^{\sin x}}{1+e^{-\cos x}}$

(i) $\tan\left(\frac{e^x}{1+e^x}\right)$

(j) $e^{\left(\frac{x}{x-1}\right)}$

(k) $e^{\left(\frac{\cos x}{1+\sin x}\right)}$

(l) $\frac{\ln\sqrt{1+x^2}}{(1+x^2)}$

4. Find the first and second derivatives with respect to x for each of the following.

(a) $(1+\sqrt{x})^3$

(b) $\sqrt{1-e^{-x}}$

(c) $\cos^2 2x$

(d) $\ln(1+x)$

(e) $e^{-\sin x}$

(f) $\tan^2 x$

5. Given that $y = (x^2 + 4x + 1) \sin x$, find $\frac{d^2y}{dx^2}$.

6. Given that $y = \sin^2 x$, prove that $\frac{d^2y}{dx^2} + 4y = 2$.

7. Given that $y = \ln \sin^3 2x$, prove that $3\frac{d^2y}{dx^2} + \left(\frac{dy}{dx}\right)^2 + 36 = 0$.

8. Given that $y = \frac{1-\sin x}{\cos x}$, prove that: (a) $\frac{dy}{dx} = \frac{-1}{1+\sin x}$ (b) $\frac{d^3y}{dx^3} = \frac{\sin x - 2}{(1+\sin x)^2}$.

11.2 Differentiating Parametric Functions

- Two variables x and y are said to be described *parametrically* if the rule is described in terms of a third variable, called the *parameter*.

- For example, the rule $y = x^2 + 1$ can be described parametrically as:
 $x = t$ and $y = t^2 + 1$.

- In general, a parametric relationship between x and y is described in the form:
 $x = f(t)$ and $y = g(t)$.

- To find $\frac{dy}{dx}$, we first determine $\frac{dy}{dt}$ and $\frac{dx}{dt}$ and use $\frac{dy}{dx} = \frac{\left(\frac{dy}{dt}\right)}{\left(\frac{dx}{dt}\right)}$.

Example 11.4

Find $\frac{dy}{dx}$ in terms of x for: (a) $x = 1 + t^3$, $y = 3t^2 - 1$ (b) $x = \sin t$, $y = \cos t$

Solution:

$$(a) \quad x = 1 + t^3 \Rightarrow \frac{dx}{dt} = 3t^2 \quad \text{and} \quad y = 3t^2 - 1 \Rightarrow \frac{dy}{dt} = 6t$$

$$\begin{aligned} \text{Hence:} \quad \frac{dy}{dx} &= \frac{6t}{3t^2} \\ &= \frac{2}{t} = \frac{2}{(x-1)^{\frac{1}{3}}} \end{aligned}$$

$$(b) \quad x = \sin t \Rightarrow \frac{dx}{dt} = \cos t \quad \text{and} \quad y = \cos t \Rightarrow \frac{dy}{dt} = -\sin t$$

$$\text{Hence:} \quad \frac{dy}{dx} = -\frac{\sin t}{\cos t}.$$

$$\text{But } \cos^2 t + \sin^2 t = 1 \Rightarrow \cos t = \pm \sqrt{1 - \sin^2 t}$$

$$\text{Hence:} \quad \frac{dy}{dx} = \pm \frac{\sin t}{\sqrt{1 - \sin^2 t}} = \pm \frac{x}{\sqrt{1 - x^2}}$$

Exercise 11.2

1. Find $\frac{dy}{dx}$. Answers should be expressed in terms of x where possible.

$$(a) \quad x = 1 + t \quad y = 3t^2 - 1$$

$$(b) \quad x = \frac{1}{t}, \quad y = t^2$$

$$(c) \quad x = t^2 \quad y = t + \frac{1}{t}$$

$$(d) \quad x = \frac{1}{t^2} \quad y = 2/t$$

2. Find $\frac{dy}{dx}$. Leave answers in terms of t .

$$(a) \quad x = t - \frac{1}{t} \quad y = 2t + \frac{1}{t}$$

$$(b) \quad x = 2t^3 + t \quad y = 3t^2 - t$$

$$(c) \quad x = \frac{1}{2} \left(t + \frac{1}{t} \right) \quad y = \frac{1}{2} \left(t - \frac{1}{t} \right)$$

$$(c) \quad x = \frac{1+2t}{1-t} \quad y = \frac{1+t}{1-2t}.$$

3. Find $\frac{dy}{dx}$. Leave answers in terms of x .

$$(a) \quad x = 2 \cos^3 t \quad y = 2 \sin^3 t$$

$$(b) \quad x = 2 - 2 \cos 2t \quad y = 4 - 2 \sin 2t$$

$$(c) \quad x = \cos t \quad y = \sin t$$

$$(d) \quad x = \sin t \quad y = \cos 2t$$

11.3 Implicit Differentiation

- Consider the expression $x^2 + xy - y^2 = 4$.
In this expression, the variables x and y are related implicitly.
The relationship between x and y is not obvious as we are not able to, without much difficulty, express y in terms of x (or x in terms of y).
- To find the derivative of $f(y)$ with respect to x , we use the chain rule as follows:

$$\frac{d}{dx} f(y) = \frac{d}{dy} f(y) \times \frac{dy}{dx}$$

- For example:

$$\begin{aligned} \frac{d}{dx} \sin(y) &= \frac{d}{dy} \sin(y) \times \frac{dy}{dx} \\ &= \cos(y) \frac{dy}{dx} \end{aligned}$$

Example 11.5

Find $\frac{dy}{dx}$ for the following: (a) $x^2 + xy - y^2 = 4$ (b) $x^2 e^y + x^2 y = 0$.

Solution:

(a) $x^2 + xy - y^2 = 4$

Differentiate both sides of the expression with respect to x :

$$2x + [y + x \frac{dy}{dx}] - 2y \frac{dy}{dx} = 0$$

```
impDiff(x^2 + x*y - y^2 = 4, x, y)
y' = -(2*x + y) / (x - 2*y)
```

Hence $\frac{dy}{dx} = \frac{-(2x + y)}{(x - 2y)}$.

(b) $x^2 e^y + x^2 y = 0$

Differentiate both sides of the expression with respect to x :

$$[2x e^y + x^2 e^y \frac{dy}{dx}] + [2xy + x^2 \frac{dy}{dx}] = 0$$

Hence: $\frac{dy}{dx} = \frac{-2(y + e^y)}{x(e^y + 1)}$.

Example 11.6

Given that $x^2 y - \sin(x) = 0$, prove that $x^2 \frac{d^2 y}{dx^2} + 4x \frac{dy}{dx} + (x^2 + 2)y = 0$.

Solution:

$$\begin{aligned} x^2 y - \sin(x) &= 0 \\ \text{Differentiate implicitly: } 2xy + x^2 \frac{dy}{dx} - \cos(x) &= 0 \end{aligned}$$

$$\text{Differentiate implicitly again: } [2y + 2x \frac{dy}{dx}] + [2x \frac{dy}{dx} + x^2 \frac{d^2 y}{dx^2}] + \sin(x) = 0$$

$$\begin{aligned} \text{Reorganise: } x^2 \frac{d^2 y}{dx^2} + 4x \frac{dy}{dx} + 2y + \sin x &= 0 \\ x^2 \frac{d^2 y}{dx^2} + 4x \frac{dy}{dx} + 2y + x^2 y &= 0 \\ x^2 \frac{d^2 y}{dx^2} + 4x \frac{dy}{dx} + (x^2 + 2)y &= 0 \end{aligned}$$

Note:

- In this example, there is no need to find dy/dx explicitly. By differentiating implicitly twice and with some reorganisation, the required proof was obtained.

Example 11.7

For $|x| < 1$, differentiate $x = \sin y$ implicitly with respect to x .

Hence, prove that $\frac{d}{dx} \sin^{-1} x = \frac{1}{\sqrt{1-x^2}}$.

Solution:

$$x = \sin y \Rightarrow y = \sin^{-1} x.$$

Differentiate $x = \sin y$ implicitly with respect to x :

$$\begin{aligned} 1 &= \cos y \times \frac{dy}{dx} \\ \frac{dy}{dx} &= \frac{1}{\cos y}. \end{aligned}$$

$$\text{But } \cos^2 y + \sin^2 y = 1 \Rightarrow \cos y = \pm \sqrt{1 - \sin^2 y} = \pm \sqrt{1 - x^2}$$

$$\text{Hence: } \frac{d}{dx} \sin^{-1} x = \frac{1}{\sqrt{1-x^2}}.$$

[Reject $-\sqrt{1-x^2}$, as the graph of $y = \sin^{-1} x$ has a positive gradient throughout.]

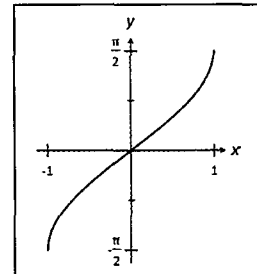

Example 11.8

Given that $x = x(t)$ and $y = y(t)$ and $z = z(t)$, determine $\frac{dA}{dt}$ for each of the following:

(a) $A = \frac{1}{x} + \sin y$ (b) $A = 4\pi x^2 y$ (c) $A = \frac{x^2}{1+y^2}$

Solution:

(a) $A = \frac{1}{x} + \sin y$

Differentiate implicitly with respect to t :

$$\begin{aligned} \frac{dA}{dt} &= -\frac{1}{x^2} \times \frac{dx}{dt} + \cos y \times \frac{dy}{dt} \\ &= -\frac{1}{x^2} \left(\frac{dx}{dt} \right) + \cos y \left(\frac{dy}{dt} \right). \end{aligned}$$

(b) $A = 4\pi x^2 y$

Differentiate implicitly with respect to t :

$$\begin{aligned} \frac{dA}{dt} &= 4\pi \left[\left(2x \frac{dx}{dt} \right) \times y + x^2 \times \frac{dy}{dt} \right] \\ &= 4\pi \left[2xy \frac{dx}{dt} + x^2 \frac{dy}{dt} \right]. \end{aligned}$$

(c) $A = \frac{x^2}{1+y^2}$

Differentiate implicitly with respect to t :

$$\begin{aligned} \frac{dA}{dt} &= \frac{(1+y^2) \times 2x \frac{dx}{dt} - x^2 \times 2y \frac{dy}{dt}}{(1+y^2)^2} \\ &= \frac{2x(1+y^2) \frac{dx}{dt} - 2x^2 y \frac{dy}{dt}}{(1+y^2)^2}. \end{aligned}$$

Note:

- This example introduces the use of implicit differentiation for functions defined in terms of several variables which are in turn defined in terms of a common parameter.
- The function A is defined in terms of x and y . x and y in turn are defined in terms of the parameter t .

Exercise 11.3 To be completed without the use of a calculator.

1. Determine $\frac{dy}{dx}$ for each of the following:

(a) $x^2 + 3xy + y^2 = 0$

(b) $x^2 - xy - y^2 = 3$

(c) $x^2 y + y^2 x = x$

(d) $x^2 + \sqrt{xy} + y^2 = 5$

(e) $ye^x + xe^y = y$

(f) $x^2 \ln(y) + xy = 4x$

2. Determine $\frac{dy}{dx}$ for each of the following:

(a) $x^2 \cos y + y \sin x = -2$

(b) $\sin y \cos x + x e^{\cos y} = 5$

(c) $4x \tan y + \cos xy = 3x$

(d) $\cos(e^y) + \ln(\sin y) + xy = 7$

(e) $\frac{1}{x} + \frac{1}{y} - e^y = 0$

(f) $x^2 = \frac{1}{y^2 + 2y - 1}$

3. Given that $x = x(t)$ and $y = y(t)$ and $z = z(t)$, determine $\frac{dA}{dt}$ for each of the following:

(a) $A = x^2 + y^2$

(b) $A = \sin x + \cos y$

(c) $A = e^{-2x} + e^{0.05y}$

(d) $A = x^2 y$

(e) $A = e^{-x} \sin \pi y$

(f) $A = x \ln(1 + \tan y)$

(g) $A = \frac{x}{y}$

(h) $A = \frac{e^{2x}}{1 + e^{-y}}$

(i) $A = \frac{\sin y}{1 + \cos x}$

4. If $(1 + x^2)y^2 = 1 - x^2$, show that $\left(\frac{dy}{dx}\right)^2 = \frac{1 - y^4}{1 - x^4}$.

5. If $x^2 + y^2 - 2y\sqrt{1 + x^2} = 0$, show that $\frac{dy}{dx} = \frac{x}{\sqrt{1 + x^2}}$.

6. If $x^2 - y^2 = 1$, prove that $y \frac{d^2 y}{dx^2} + \left(\frac{dy}{dx}\right)^2 = 1$.

7. If $y^2 - 2xy - 2x = 0$, prove that $(x - y) \frac{d^2 y}{dx^2} - \frac{dy}{dx} \left[\frac{dy}{dx} - 2 \right] = 0$.

8. If $y e^{2x} - 2 \sin(x) = 0$, prove that $\frac{d^2 y}{dx^2} + 4 \frac{dy}{dx} + 5y = 0$.

9. If $y = \frac{\cos(x) - \sin(x)}{\cos(x) + \sin(x)}$, prove that $\frac{d^2 y}{dx^2} + 2y \frac{dy}{dx} = 0$.

10. If $y = \frac{\sin x}{x^2}$, prove that $x^2 \frac{d^2 y}{dx^2} + 4x \frac{dy}{dx} + (x^2 + 2)y = 0$.

11. If $y = 2e^{-2x} \sin x$, prove that $\frac{d^2 y}{dx^2} + 4 \frac{dy}{dx} + 5y = 0$.

12. For $|x| < 1$, differentiate $x = \cos y$ implicitly with respect to x .

Hence, prove that $\frac{d}{dx} \cos^{-1} x = \frac{-1}{\sqrt{1-x^2}}$.

13. Differentiate $x = \tan y$ implicitly with respect to x .

Hence, prove that $\frac{d}{dx} \tan^{-1} x = \frac{1}{1+x^2}$.

11.4 Logarithmic Differentiation

- We can combine the use of the rules of logarithms and the technique of implicit differentiation to differentiate complicated expressions. This composite technique is often known as logarithmic differentiation.

Example 11.9

Find $\frac{dy}{dx}$ for each of the following: (a) $y = 2^{\sqrt{x}}$ (b) $y = \sqrt{\frac{x-1}{x+1}}$.

Solution:

(a) $y = 2^{\sqrt{x}}$

Take logarithms of both sides:

$$\ln(y) = \ln(2^{\sqrt{x}})$$

$$\ln(y) = \sqrt{x} \ln(2)$$

Differentiate implicitly:

$$\frac{1}{y} \frac{dy}{dx} = \frac{\ln(2)}{2\sqrt{x}}$$

$$\frac{dy}{dx} = y \times \frac{\ln(2)}{2\sqrt{x}}$$

$$= \frac{2^{\sqrt{x}} \ln(2)}{2\sqrt{x}}$$

$$(b) y = \sqrt{\frac{x-1}{x+1}}$$

Take logarithms on both sides:

$$\ln(y) = \ln \sqrt{\frac{x-1}{x+1}}$$

$$\ln(y) = \frac{1}{2} [\ln(x-1) - \ln(x+1)]$$

Differentiate implicitly:

$$\begin{aligned} \frac{1}{y} \frac{dy}{dx} &= \frac{1}{2} \left[\frac{1}{x-1} - \frac{1}{x+1} \right] \\ \frac{dy}{dx} &= \frac{y}{2} \left[\frac{2}{(x-1)(x+1)} \right] \\ &= \frac{1}{(x-1)^{\frac{1}{2}}(x+1)^{\frac{3}{2}}} \end{aligned}$$

Exercise 11.4

1. Use the technique of logarithmic differentiation to differentiate the following expressions with respect to x :

(a) 2^x

(b) x^x

(c) 2^{2x}

(d) $x^{\ln(x)}$

(e) $x^{\sin(x)}$

(f) $x^{\cos(x)}$

(g) $(1+x)^x$

(h) $\left(\frac{1}{x}\right)^x$

(i) $[\ln(x)]^{\ln(x)}$

2. Use the technique of logarithmic differentiation to differentiate the following expressions with respect to x :

(a) $\frac{1+x}{1-x}$

(b) $\frac{1+x^2}{1-x^3}$

(c) $\frac{1+x-x^2}{1-x^3}$

(d) $\frac{(1+x^2)^2}{(1-2x^3)}$

(e) $\frac{(1-2x)^3}{(x+2)^4}$

(f) $\frac{(2+\sqrt{x})^2}{(\sqrt{x}-1)^3}$

(g) $\sqrt{\frac{2x}{1-3x}}$

(h) $\sqrt{\frac{1+x}{3x+4}}$

(i) $\sqrt{\frac{1+x^2}{1-x^2}}$

12 Applications of Differentiation

12.1 The Gradient Function for Implicit Functions

- This section extends the concept of the gradient function introduced in Mathematics Methods Units 1 & 2 and Mathematics Methods Units 3 & 4, to implicit functions.
- Recall that for the curve $y = f(x)$, the gradient function is $\frac{dy}{dx} = f'(x)$.
 - The gradient of the curve at $(a, f(a))$ is $\left. \frac{dy}{dx} \right|_{x=a} = f'(a)$.
- The gradient function of an implicitly defined curve $f(x, y) = 0$, is given by $\frac{dy}{dx} = g(x, y)$.
 - The gradient of the curve at (a, b) is given by $\left. \frac{dy}{dx} \right|_{x=a, y=b} = g(a, b)$.

Example 12.1

Find the equation of the tangent to the curve $x^2 + y^2 - 8x - 6y + 17 = 0$ at the point with coordinates $(2, 1)$.

Solution:

$$x^2 + y^2 - 8x - 6y + 17 = 0$$

Differentiating implicitly: $2x + 2y \frac{dy}{dx} - 8 - 6 \frac{dy}{dx} = 0$

Substitute $x = 2, y = 1$ $4 + 2 \frac{dy}{dx} - 8 - 6 \frac{dy}{dx} = 0$

$$\Rightarrow \frac{dy}{dx} = -1$$

Therefore, the gradient of tangent at $(2, 1)$ is given by $m = -1$.

Hence, equation of tangent is $y - (1) = -1[x - (2)]$

$$y = -x + 3$$

Notes:

- Notice that the gradient of the tangent can be obtained without determining the expression for dy/dx .
- Unless required, it is not necessary to obtain an explicit expression for dy/dx .

Example 12.2

A curve has equation $y^2 + xy - 2 = 0$. Find the coordinates of the points on this curve where the gradient of the curve is $-\frac{1}{3}$.

Solution:

$$y^2 + xy - 2 = 0$$

Differentiating implicitly with respect to x :

$$2y \left(\frac{dy}{dx} \right) + y + x \left(\frac{dy}{dx} \right) = 0$$

$$\frac{dy}{dx} = \frac{-y}{(x+2y)}$$

$$\text{When gradient} = -\frac{1}{3}: \quad \frac{-y}{(x+2y)} = -\frac{1}{3}$$

$$\Rightarrow y = x.$$

Hence:

$$x^2 + x^2 - 2 = 0$$

$$\Rightarrow x = \pm 1$$

When $x = 1, y = 1$ and when $x = -1, y = -1$.

Therefore, required points are $(-1, -1)$ and $(1, 1)$.

Exercise 12.1

- Find the equation of the tangent to each of the following curves at the indicated point:
 - $x^3 + y^3 + 3xy - 1 = 0$ at the point where $x = 2$
 - $x^2 + xy^2 + 3xy - 1 = 0$ at the point where $x = 1$
 - $x \cos(y) + y = \pi/3$ at the point where $x = 0$
 - $x \ln(2+y) + xy = 1$ at the point where $y = -1$.
- A curve has equation $y e^x + \cos(x) = 2$. Find the equation of the tangent to this curve at the point where $x = 0$.
- A curve has equation $\sqrt{1+y} + xy = 2$. Find the equation of the tangent to this curve at the point where $y = 3$.
- A curve has equation $x^2 + y^2 + 2y - 4 = 0$. Find the coordinates of the points on this curve where the gradient of the curve is 2.
- A curve has equation $x^2 + y^2 + xy - 4 = 0$. Find the coordinates of the points on this curve where the curve is parallel to the line $y = x$.

6. A curve has equation $2x^2 + y^2 + xy - 2 = 0$. Find the coordinates of the points on this curve where the curve is parallel to the line $y = 3x + 1$.
7. A curve has equation $x^2 + \sin y - 1 = 0$. Find the coordinates of the points on this curve where the curve is parallel to the line $y = -2x + 3$.
8. Find the equation of the tangent(s) to the curve $xy^2 + x^2y = 2$ that is:
 - (a) parallel to the x -axis
 - (b) parallel to the y -axis.
9. Consider the curve with equation $2y^3 - 3y^2 - 3x^2 - 12x = 12$. Find the equation of the tangent to the curve that is parallel to the: (a) y -axis (b) x -axis.
10. Consider the curve with equation $x^2 + 2\pi \cos y + 2\pi y = 0$. Find the equation of the tangent to the curve that is parallel to the: (a) y -axis (b) x -axis.

12.2 Related Rates

- Consider $y = f(x)$ where $x = g(t)$, to find the rate of change of y with respect to t , we differentiate y implicitly with respect to t : $\frac{dy}{dt} = \frac{d}{dx} f(x) \times \frac{dx}{dt}$.
- Hence, the rate of change $\frac{dy}{dt}$ is related to the rate of change $\frac{dx}{dt}$.

Example 12.3

For $y = 10 e^{0.05x}$, where $x = f(t)$, find $\frac{dy}{dt}$, given that when $x = 0$, $\frac{dx}{dt} = 1.2$.

Solution:

$$y = 10 e^{0.05x}$$

Differentiate implicitly with respect to t :

$$\frac{dy}{dt} = 0.5 e^{0.05x} \frac{dx}{dt}$$

When $x = 0$, $\frac{dx}{dt} = 1.2$.

$$\begin{aligned} \text{Hence, } \frac{dy}{dt} &= 0.5 e^{0.05(0)} (1.2) \\ &= 0.6 \end{aligned}$$

Example 12.4

The volume of a spherical balloon is increasing at a rate of 1 cm³ per minute. Find the rate of change of the radius of the balloon when the volume of the balloon is $\frac{4\pi}{3}$ cm³.

Solution:

Volume V of sphere of radius r :
$$V = \frac{4}{3}\pi r^3.$$

Clearly, V and r are each functions of time t .

Differentiate implicitly with respect to t :
$$\frac{dV}{dt} = 4\pi r^2 \frac{dr}{dt}$$

When $V = \frac{4\pi}{3}$, radius $r = 1$ cm.

Since $\frac{dV}{dt} = 1$:
$$1 = 4\pi \frac{dr}{dt}$$

Hence:
$$\frac{dr}{dt} = \frac{1}{4\pi} \text{ cm per minute.}$$

Example 12.5

A ladder 7m long rests against a vertical wall, and is standing on flat ground. The bottom of the ladder is being pushed along the ground and towards the wall at a steady rate of 0.1 ms⁻¹. How fast is the top sliding up the wall when the bottom is 2 m out from the wall?

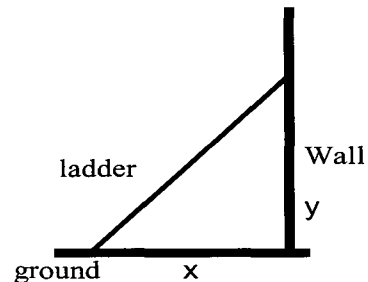
**Solution:**

Let x and y be the horizontal and vertical distances of the bottom of the ladder from the foot of the wall.

Using Pythagoras' Theorem,
$$x^2 + y^2 = 49.$$

Differentiate implicitly with respect to t (x and y are both functions of time t):

$$2x \frac{dx}{dt} + 2y \frac{dy}{dt} = 0$$

The rate at which x changes, $\frac{dx}{dt} = -0.1$ (constant).

Also, when $x = 2$, $y = \sqrt{45} = 3\sqrt{5}$.

Hence, when $x = 2$:

$$2(2)(-0.1) + 2(3\sqrt{5}) \frac{dy}{dt} = 0$$

$$\frac{dy}{dt} = \frac{\sqrt{5}}{75} \text{ ms}^{-1}$$

Example 12.6

Elle who is 1.8 m tall walks beneath a street lamp that is 9 m above ground level. If Elle walks at a speed of 1 ms^{-1} towards the lamp, find the rate with which the length of Elle's shadow is changing when she is 4 m from the street lamp.

Solution:

Let the distance between Elle and the lamp be x cm.
Let the length of Elle's shadow be y cm.

Using similar triangles:

$$\frac{y}{1.8} = \frac{x+y}{9}$$

$$y = \frac{x}{4}$$

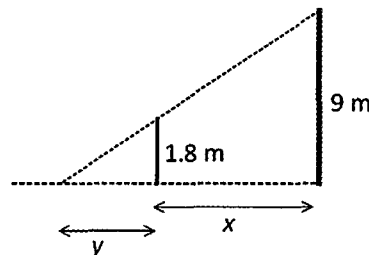

Differentiate implicitly with respect to time t :

$$\frac{dy}{dt} = \frac{1}{4} \frac{dx}{dt}$$

When $\frac{dx}{dt} = -1$:

$$\frac{dy}{dt} = \frac{1}{4} \times -1$$

$$= -\frac{1}{4} \text{ ms}^{-1}$$

Example 12.7

$\triangle ABC$ is an isosceles triangle with sides $AB = AC = 10$ cm.
 $\angle BAC = \theta$ radians. $\angle BAC$ changes at a rate of 1 radian per minute. Find the rate with which the length of side BC is changing when $\angle BAC = \frac{\pi}{3}$ radians.

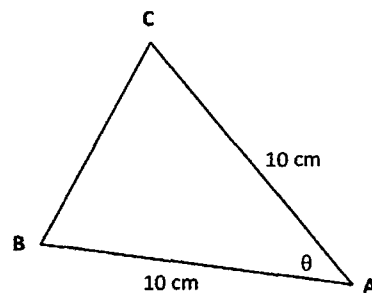

Solution:

Let $BC = x$ cm.

Using the cosine rule:

$$x^2 = 10^2 + 10^2 - 2 \times 10 \times 10 \times \cos \theta$$

$$x^2 = 200 - 200 \cos \theta$$

Differentiate implicitly with respect to time t :

$$2x \frac{dx}{dt} = 200 \sin \theta \frac{d\theta}{dt}$$

$$\frac{dx}{dt} = \left(\frac{100 \sin \theta}{x} \right) \frac{d\theta}{dt}$$

$$\frac{dx}{dt} = \left(\frac{100 \sin \frac{\pi}{3}}{10} \right)$$

$\frac{d\theta}{dt} = 1$ and when $\theta = \frac{\pi}{3}$, $x = 10$ cm:

$$= 5\sqrt{3} \text{ cm per minute.}$$

Example 12.8

The light beam in a lighthouse 1 km offshore from a straight coastline is rotating at 2 revolutions per second. Find how fast the beam of light is moving along the shoreline when the beam is at a point which is 1 km from the point directly opposite the lighthouse.

Solution:

Let K be the point on the shoreline directly opposite the lighthouse L. Hence, $LK = 1$ km.

Let path of light beam be LB where B is the point where the light beam meets the shoreline.

Let $KB = x$ km and $\angle KLB = \theta$ radians.

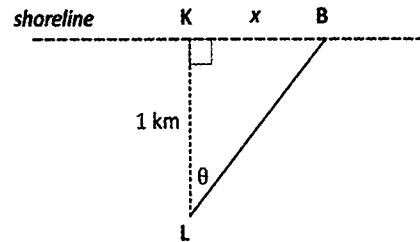

In $\triangle LKB$: $\tan \theta = x$

Differentiate implicitly with respect to time t :

$$\sec^2 \theta \frac{d\theta}{dt} = \frac{dx}{dt}$$

$$\frac{d\theta}{dt} = 2 \text{ revolutions per second} = 4\pi \text{ radians per second.}$$

$$\begin{aligned} \text{When } x = 1, \sec \theta = \sqrt{2}: \quad &\Rightarrow \frac{dx}{dt} = (\sqrt{2})^2 \times 4\pi \\ &= 8\pi \text{ km per second.} \end{aligned}$$

Exercise 12.2

- For $y = \sqrt{1+x}$, where $x = f(t)$, find $\frac{dy}{dt}$ given that when $x = 3$, $\frac{dx}{dt} = 0.4$.
- For $y = \ln(1 + 5x)$, where $x = f(t)$, find $\frac{dy}{dt}$ given that when $x = 0$, $\frac{dx}{dt} = -0.5$.
- For $x^2 + y^2 = 100$ where $x > 0$ and $y > 0$, and where $x = f(t)$ and $y = g(t)$, find:
 - $\frac{dy}{dt}$ given that when $x = 6$, $\frac{dx}{dt} = 0.2$
 - $\frac{dx}{dt}$ given that when $y = 5$, $\frac{dy}{dt} = -0.3$.
- For $xy + \sin(y) = 1/2$, where $x = f(t)$ and $y = g(t)$ such that $0 \leq y \leq \frac{\pi}{2}$, find:
 - $\frac{dy}{dt}$ given that when $x = 0$, $\frac{dx}{dt} = 0.2$
 - $\frac{dx}{dt}$ given that when $y = \pi/6$, $\frac{dy}{dt} = 2$.
- The side of a square is increasing at the rate of 0.2 cms^{-1} . When the area is 25 cm^2 , find the rate at which (i) the area and (ii) the perimeter of the square is changing.
- The diameter of the iris (assumed circular) of a mammal is dilating at a rate of 0.01 mm s^{-1} . Find the rate at which the (i) circumference (ii) area of the dilated opening is changing when the radius of the dilated opening is 0.5 mm .

7. Rain water is being channelled by downpipes into a cylindrical rain water tank at a rate of 0.2 m^3 per minute. If the rain water tank has a base radius of 5 m, find the rate at which the depth of the water level is changing when its depth is 0.5 m.
8. The radius of a spherical balloon is increasing at a constant rate of 1 cms^{-1} . Find the rate with which: (i) the volume and (ii) the surface area of the balloon is changing when the radius is $\pi \text{ cm}$.
9. The surface area of a spherical balloon undergoing inflation is increasing at a rate of $10 \text{ cm}^2 \text{ s}^{-1}$. Find the rate at which (i) the radius and (ii) the volume of the balloon is changing when the surface area is 2000 cm^2 .
10. Wheat grains falls from a conveyor belt onto a conical pile at the rate of 2 m^3 per minute. The radius of the base of the pile is always equal to half the height of the cone. Find the rate at which the height of the conical pile is changing when the height is 5 m.
11. Water is leaking from the base of an inverted cone at a rate to $\pi \text{ cm}^3$ per minute. The base radius and height of the cone are 20 cm and 50 cm respectively. Find the rate with which the height of the water level measured from the apex of the cone is changing when the volume of water left in the cone is $5\pi/6 \text{ cm}^3$.
12. An empty inverted right circular cone of semi-vertical angle 30° and height 100 cm is filled with water. Water is siphoned into the cone from the open end at a steady rate of 5 cm^3 per minute. Find the rate with which the water level is changing when the water level is 50cm from the vertex of the cone.
13. A ladder 10 m long rests against a high tension electricity pole, and is standing on flat ground. The bottom of the ladder is being pulled along the ground away from the foot of the pole at a steady rate of 0.1 ms^{-1} . How fast is the top sliding along the pole when the bottom is 3 m out from the foot of the pole?
14. A ladder 8 m long standing on flat ground, rests against a wall. The top of the ladder is sliding down the wall at a steady rate of 0.2 ms^{-1} . How fast is the bottom of the ladder sliding along the ground when the top is 2 m from the foot of the wall?
15. Jason who is 1.7 m tall walks beneath a light source that is 15 m above ground level. If Jason walks at a speed of 5 kmh^{-1} away from the base of the light source, find the rate with which the length of Jason's shadow is changing when he is 4 m from the base of the light source.
16. Aimee who is 125 cm tall walks beneath a street lamp that is 10 m above ground level. If Aimee walks at a speed of 20 m per minute towards the lamp, find the rate with which the tip of Aimee's shadow is changing when she is 2m from the base of the street lamp.

17. A balloon is released from ground level at a point 50 metres from an observer who is also at ground level. The balloon ascends vertically at a rate of 1 ms^{-1} . Find the rate with which the angle of elevation of the balloon from the observer is changing when the balloon is at a height of 50 m.
18. A boy standing on a cliff is “tracking” a boat through a telescope as the boat approaches the base of the cliff directly below him. The telescope is 100 m above the water level and the boat is approaching a point on the base of the cliff directly below the telescope, in a direction that is perpendicular to the coast line with a speed of 2 ms^{-1} . Find the rate at which the angle of depression of the telescope is changing when the boat is 200m from the base of the cliff.
19. A toy train is moving anti-clockwise around a circular track with equation $x^2 + y^2 = 169$. At the point (12, 5), the x -coordinate of the train is decreasing at a rate of 1 cm per second. Find the rate with which the y -coordinate of the train is changing at this instant.
20. A toy train is moving clockwise around a circular track with equation $x^2 + y^2 = 100$ at the rate of one revolution every minute. Determine how fast the x -coordinate of the train is changing at the instant the train passes through the point (6, 8). Measurements are in cm.
21. The light in a lighthouse 2.5 km offshore from a straight coastline is rotating at 3 revolutions per minute. Find how fast the beam is moving along the shoreline when the beam is at a point which is 1 km from the point directly opposite the lighthouse.
22. Object A is located at P 20 m East of Object B. Object A starts moving Northwards at a rate of 10 ms^{-1} while object B starts moving Westwards at 5 ms^{-1} . Find the rate of separation between the objects A and B after 30 seconds.
23. Particle A is located 500 m North of O and particle B is located 800 m West of O. A starts moving Southwards at a rate of 5 ms^{-1} while B starts moving Eastwards at 10 ms^{-1} . Find the rate of approach between A and B after 10 seconds.
24. The Dockers Bridge passes over the West Coast Freeway. The freeway is 20 m below the bridge and at right angles to it. A car travelling at 12 ms^{-1} on the bridge is directly above another car travelling at 24 ms^{-1} on the freeway. Find how fast the cars will be separating 1 minute later.
25. The hands of a analogue clock” are 18 cm (minute hand) and 12 cm (hour hand) long respectively. Determine the rate at which the distance between the tips of the hands is changing at 9 o’clock.

13 Anti-Differentiation

- In this chapter we will review and extend the rules of anti-differentiation as introduced in Mathematics Methods Units 3 & 4.

13.1 Anti-Differentiation as the reverse of Differentiation

- Recall that if $\frac{d}{dx} f(x) = f'(x)$, then $\int f'(x) dx = f(x) + C$.

Example 13.1

Given that $\frac{d}{dx} \left[x \sin(2x) + \frac{\cos(2x)}{2} \right] = 2x \cos(2x)$, find $\int x \cos(2x) dx$.

Solution:

Clearly, since $\frac{d}{dx} \left[x \sin(2x) + \frac{\cos(2x)}{2} \right] = 2x \cos(2x)$

$$\int 2x \cos(2x) dx = x \sin(2x) + \frac{\cos(2x)}{2} + k$$

$$2 \int x \cos(2x) dx = x \sin(2x) + \frac{\cos(2x)}{2} + k$$

$$\int x \cos(2x) dx = \frac{1}{2} \left[x \sin(2x) + \frac{\cos(2x)}{2} \right] + C$$

Exercise 13.1

1. Given that $\frac{d}{dx} [x \sin(x) + \cos(x)] = x \cos(x)$, find $\int x \cos(x) dx$.
2. Given that $\frac{d}{dx} [e^x (\sin(x) + \cos(x))] = 2e^x \cos(x)$, find $\int e^x \cos(x) dx$.
3. Given that $\frac{d}{dx} [x \ln(x) - x] = \ln(x)$, find $\int 2 \ln(x) dx$.
4. Given that $\frac{d}{dx} [x e^x - e^x] = x e^x$, find $\int x e^x + x dx$.

5. Differentiate e^{x^2} with respect to x . Hence, find $\int x e^{x^2} dx$.
6. Differentiate $e^{\cos(x)}$ with respect to x . Hence, find $\int \sin(x) e^{\cos(x)} dx$.
7. Differentiate $e^{-x} [\sin(x) + \cos(x)]$ with respect to x . Hence, find $\int [e^{-x} \sin(x)] dx$.
8. Differentiate $(x^2 + 2x + 2) e^{-x}$ with respect to x . Hence, determine $\int [x^2 e^{-x}] dx$.
9. Differentiate $e^{-x} [1 + x]$ with respect to x . Hence, determine $\int [x(e^{-x} - 1)] dx$.
10. Differentiate $x^2 [2 \ln(x) - 1]$ with respect to x . Hence, determine $\int \{x[x + \ln(x)]\} dx$.
11. Given that $f(x) = g'(x)$, $h(x) = k'(x)$, where $g(x) = (\sqrt{x} + 1)^2$ and $k(x) = e^x$, find:
 (a) $\int f(x) dx$ (b) $\int h(x) dx$ (c) $\int f(x) + h(x) dx$ (d) $\int x + f(x) dx$.

13.2 Anti-differentiation I

- The table below lists the anti-derivatives for several commonly used functions.

Function	Anti-derivative
x^n where $n \neq -1$	$\frac{x^{n+1}}{n+1} + C$
$(ax + b)^n$ where $n \neq -1$	$\frac{(ax + b)^{n+1}}{a(n+1)} + C$
e^{mx}	$\frac{e^{mx}}{m} + C$
$f'(x) e^{f(x)}$	$e^{f(x)} + C$

- The generic rules for anti-derivatives are listed below:
 - $\int a f(x) + b g(x) dx = a \int f(x) dx + b \int g(x) dx$ for constants a and b .
 - $\int f'(x) \cdot [f(x)]^n dx = \frac{[f(x)]^{n+1}}{n+1} + C$ where $n \neq -1$.

Example 13.2

Without the use of a calculator, anti-differentiate each of the following with respect to x :

(a) $\frac{x^2 + 3x}{x^4}$ (b) $\frac{1}{\sqrt{1-2x}}$ (c) $(x^2 + 1)^2$

Solution:

$$\begin{aligned} \text{(a)} \quad \int \frac{x^2 + 3x}{x^4} dx &= \int x^{-2} + 3x^{-3} dx \\ &= -\frac{1}{x} - \frac{3}{2x^2} + C \end{aligned}$$

$$\begin{aligned} \text{(b)} \quad \int \frac{1}{\sqrt{1-2x}} dx &= \int (1-2x)^{-\frac{1}{2}} dx \\ &= \frac{(1-2x)^{\frac{1}{2}}}{\left(\frac{1}{2}\right)(-2)} + C \\ &= -\sqrt{1-2x} + C \end{aligned}$$

$$\begin{aligned} \text{(c)} \quad \int (x^2 + 1)^2 dx &= \int x^4 + 2x^2 + 1 dx \\ &= \frac{x^5}{5} + \frac{2x^3}{3} + 1 + C. \end{aligned}$$

Example 13.3

Without the use of a calculator, anti-differentiate each of the following with respect to x :

(a) $x\sqrt{1+x^2}$ (b) $\frac{3x}{\sqrt{1-x^2}}$

Solution:

$$\begin{aligned} \text{(a)} \quad \int x\sqrt{1+x^2} dx &= \int x(1+x^2)^{\frac{1}{2}} dx \\ &= \frac{1}{2} \int 2x(1+x^2)^{\frac{1}{2}} dx \\ &= \frac{1}{2} \left[\frac{(1+x^2)^{\frac{3}{2}}}{\frac{3}{2}} \right] + C \\ &= \frac{1}{3}(1+x^2)^{\frac{3}{2}} + C \end{aligned}$$

$$\begin{aligned} \int f'(x) \cdot [f(x)]^n dx \\ &= \frac{[f(x)]^{n+1}}{n+1} + C \end{aligned}$$

$$\begin{aligned}
 \text{(b)} \quad \int \frac{3x}{\sqrt{1-x^2}} dx &= \frac{3}{-2} \int -2x(1-x^2)^{-\frac{1}{2}} dx \\
 &= -\frac{3}{2} \left[\frac{(1-x^2)^{\frac{1}{2}}}{\frac{1}{2}} \right] + C \\
 &= -3(1-x^2)^{\frac{1}{2}} + C
 \end{aligned}$$

$$\begin{aligned}
 \int f'(x) \cdot [f(x)]^n dx \\
 = \frac{[f(x)]^{n+1}}{n+1} + C
 \end{aligned}$$

Example 13.4

Without the use of a CAS calculator, integrate each of the following with respect to x :

$$\text{(a)} \quad \frac{1-e^x}{e^x} \qquad \text{(b)} \quad \frac{x}{e^{2x^2}}$$

Solution:

$$\begin{aligned}
 \text{(a)} \quad \int \frac{1-e^x}{e^x} dx &= \int e^{-x} - 1 dx \\
 &= -\frac{1}{e^x} - x + C
 \end{aligned}$$

$$\begin{aligned}
 \text{(c)} \quad \int \frac{x}{e^{2x^2}} dx &= \frac{1}{-4} \int -4x e^{-2x^2} dx + C \\
 &= -\frac{1}{4} e^{-2x^2} + C.
 \end{aligned}$$

$$\begin{aligned}
 \int f'(x) e^{f(x)} dx \\
 = e^{f(x)} + C
 \end{aligned}$$

Exercise 13.2 *To be completed without the use of a calculator.*

1. Anti-differentiate each of the following with respect to x .

$$\begin{array}{llll}
 \text{(a)} \quad \frac{2}{\sqrt{x}} & \text{(b)} \quad \frac{3}{4\sqrt{x}} & \text{(c)} \quad \frac{1}{(2t+1)^3} & \text{(d)} \quad \frac{2}{\sqrt{1-4x}} \\
 \text{(e)} \quad (x+1)^3 & \text{(f)} \quad \frac{(x+2)^2}{x^4} & \text{(g)} \quad (x^3+1)^2 & \text{(h)} \quad (t^2-1)^3
 \end{array}$$

2. Integrate each of the following with respect to x .

$$\begin{array}{llll}
 \text{(a)} \quad 4x(1+x^2)^3 & \text{(b)} \quad 3x\sqrt{1-2x^2} & \text{(c)} \quad \frac{-3x^2}{(1-x^3)^4} & \text{(d)} \quad \frac{6x^2}{\sqrt{1+x^3}} \\
 \text{(e)} \quad (x+1)(x^2+2x)^3 & \text{(f)} \quad \frac{2-2x}{(2x-x^2)^3} & \text{(g)} \quad \frac{1}{x^2} \left(1-\frac{1}{x}\right)^3 & \text{(h)} \quad \frac{1}{\sqrt{x}}(1+\sqrt{x})^4
 \end{array}$$

3. Integrate each of the following with respect to the appropriate variable.

(a) $\frac{2e^{0.05x}}{5}$

(b) $\frac{1}{2e^{0.1x}}$

(c) $\sqrt{e^{4x}}$

(d) $\frac{2}{(e^{2x})^3}$

(e) $(2e^x + 1)^2$

(f) $\frac{e^x - e^{2x}}{e^x}$

(g) $\left(e^x + \frac{2}{e^x}\right)^2$

(h) $\frac{(1 + 2e^x)^2}{e^{2x}}$

4. Integrate each of the following with respect to the appropriate variable.

(a) $\frac{x e^{2x^2}}{4}$

(b) $\frac{3x}{2e^{x^2}}$

(c) $x e^{1+x^2}$

(d) $\frac{2x}{e^{4-x^2}}$

(e) $(x+1)e^{x^2+2x}$

(f) $e^x(1+e^x)^4$

(g) $e^{2x}\sqrt{e^{2x}-1}$

(h) $\frac{e^x}{(1+2e^x)^5}$

13.3 Anti-derivative of $\frac{f'(x)}{f(x)}$

• Since $\frac{d}{dx} \ln f(x) = \frac{f'(x)}{f(x)} \Rightarrow \int \frac{f'(x)}{f(x)} dx = \ln |f(x)| + C.$

• In particular:

$$\int \frac{1}{x} dx = \ln |x| + C.$$

Example 13.5

Without the use of a CAS calculator, integrate each of the following with respect to x :

(a) $\frac{1-3x}{2x^2}$

(b) $\frac{3x}{1-x^2}$

Solution:

(a)
$$\int \frac{1-3x}{2x^2} dx = \int \frac{x^{-2}}{2} - \frac{3}{2x} dx$$

$$= -\frac{1}{2x} - \frac{3}{2} \ln |x| + C$$

(b)
$$\int \frac{3x}{1-x^2} dx = \frac{3}{-2} \int \frac{-2x}{1-x^2} dx$$

$$= -\frac{3}{2} \ln |1-x^2| + C$$

Example 13.6

Without the use of a CAS calculator, integrate each of the following with respect to x :

(a) $\frac{4e^{2x}}{1+3e^{2x}}$ (b) $\frac{4}{\sqrt{x}(1-\sqrt{x})}$

Solution:

$$\begin{aligned} \text{(a)} \quad \int \frac{4e^{2x}}{1+3e^{2x}} dx &= \frac{4}{6} \int \frac{6e^{2x}}{1+3e^{2x}} dx \\ &= \frac{2}{3} \ln |1+3e^{2x}| + C \end{aligned}$$

$$\begin{aligned} \text{(b)} \quad \int \frac{4}{\sqrt{x}(1-\sqrt{x})} dx &= -8 \int \frac{\left(\frac{1}{2\sqrt{x}}\right)}{(1-\sqrt{x})} dx \\ &= -8 \ln |1-\sqrt{x}| + C \end{aligned}$$

Exercise 13.3 *To be completed without the use of a calculator.*

1. Integrate each of the following with respect to x .

(a) $\frac{2}{1+3x}$ (b) $\frac{4}{2-5x}$ (c) $\frac{(x-2)^2}{4x}$ (d) $\frac{(1+2x)^3}{3x^2}$
 (e) $\left(1-\frac{1}{x}\right)^2$ (f) $\left(1+\frac{1}{x}\right)^3$ (g) $\frac{7x}{1-3x^2}$ (h) $\frac{-3x^2}{2x^3-1}$

2. Find the anti-derivative of:

(a) $\frac{4-x}{x^2-8x}$ (b) $\frac{9+6x}{x^2+3x}$ (c) $\frac{x^2+2x+1}{(1+x)^3}$
 (d) $\frac{5e^{-2x}}{1+2e^{-2x}}$ (e) $\frac{3xe^{x^2}}{1+2e^{x^2}}$ (f) $\frac{e^{2x}-e^{-2x}}{e^{2x}+e^{-2x}}$
 (g) $\frac{3}{\sqrt{x}(1+\sqrt{x})}$ (h) $\frac{3}{2x^2(1+\frac{1}{x})}$ (i) $\frac{1}{x \ln(x)}$

3. Find:

(a) $\int 1 d(x^2)$ (b) $\int x^4 d(x^2)$ (c) $\int x^2 d(x^4)$ (d) $\int 1+\sqrt{x} d(\sqrt{x})$

13.4 Standard Trigonometric Integrals

- The following table gives the anti-derivatives of some trigonometric functions involving linear factors (without the constants of integration).

Function	Anti-derivative
$\sin(ax + b)$	$\frac{-\cos(ax + b)}{a}$
$\cos(ax + b)$	$\frac{\sin(ax + b)}{a}$
$\sec^2(ax + b)$	$\frac{\tan(ax + b)}{a}$
$\operatorname{cosec}^2(ax + b)$	$\frac{-\cot(ax + b)}{a}$

- In many instances, the use of certain trigonometric identities is required. Listed below are some of the commonly required trigonometric identities.

- $\sin^2 A + \cos^2 A = 1$
- $1 + \tan^2 A = \sec^2 A$
- $1 + \cot^2 A = \operatorname{cosec}^2 A$
- $\sin 2A = 2 \sin A \cos A$
- $\cos 2A = \cos^2 A - \sin^2 A$
 $= 2 \cos^2 A - 1$
 $= 1 - 2 \sin^2 A$

Example 13.7

Without the use of a calculator, determine: (a) $\int \sin\left(\frac{\pi}{4} - 2x\right) dx$ (b) $\int \sec^2(1 - \pi x) dx$.

Solution:

$$\begin{aligned} \text{(a)} \quad \int \sin\left(\frac{\pi}{4} - 2x\right) dx &= \frac{-\cos\left(\frac{\pi}{4} - 2x\right)}{-2} + C \\ &= \frac{1}{2} \cos\left(\frac{\pi}{4} - 2x\right) + C \end{aligned}$$

$$\begin{aligned} \text{(b)} \quad \int \sec^2(1 - \pi x) dx &= \frac{\tan(1 - \pi x)}{-\pi} + C \\ &= -\frac{1}{\pi} \tan(1 - \pi x) + C \end{aligned}$$

Example 13.8

Without the use of a calculator, determine: (a) $\int \cos(x)\sqrt{1-\sin(x)} dx$ (b) $\int \sin 2x \cos x dx$.

Solution:

$$\begin{aligned} \text{(a)} \quad \int \cos(x)\sqrt{1-\sin(x)} dx &= -\int -\cos x (1-\sin x)^{\frac{1}{2}} dx \\ &= -\frac{(1-\sin x)^{\frac{3}{2}}}{\frac{3}{2}} + C \\ &= -\frac{2}{3}(1-\sin x)^{\frac{3}{2}} + C \end{aligned}$$

$$\begin{aligned} \int f'(x) \cdot [f(x)]^n dx \\ = \frac{[f(x)]^{n+1}}{n+1} + C \end{aligned}$$

$$\begin{aligned} \text{(c)} \quad \int \sin 2x \cos x dx &= \int (2 \sin x \cos x) \cos x dx \\ &= -2 \int -\sin x (\cos x)^2 dx \\ &= \frac{-2(\cos x)^3}{3} + C \\ &= -\frac{2}{3} \cos^3 x + C. \end{aligned}$$

$$\sin 2A = 2 \sin A \cos A$$

$$\begin{aligned} \int f'(x) \cdot [f(x)]^n dx \\ = \frac{[f(x)]^{n+1}}{n+1} + C \end{aligned}$$

Example 13.9

Without the use of a calculator, determine:

$$\text{(a)} \int \tan(\pi x + 1) dx \quad \text{(b)} \int \frac{3 \cos 2x}{1 + \sin 2x} dx$$

Solution:

$$\begin{aligned} \text{(a)} \quad \int \tan(\pi x + 1) dx &= \int \frac{\sin(\pi x + 1)}{\cos(\pi x + 1)} dx \\ &= \frac{1}{-\pi} \int \frac{-\pi \sin(\pi x + 1)}{\cos(\pi x + 1)} dx \\ &= -\frac{1}{\pi} \ln |\cos(\pi x + 1)| + C \end{aligned}$$

$$\begin{aligned} \int \frac{f'(x)}{f(x)} dx \\ = \ln |f(x)| + C. \end{aligned}$$

$$\begin{aligned} \text{(b)} \quad \int \frac{3 \cos 2x}{1 + \sin 2x} dx &= \frac{3}{2} \int \frac{2 \cos 2x}{1 + \sin 2x} dx \\ &= \frac{3}{2} \ln |1 + \sin 2x| + C \end{aligned}$$

Example 13.10

Without the use of a calculator, determine:

(a) $\int 1 + \tan^2 \pi x \, dx$ (b) $\int (1 + \tan^2 x) \tan^3 x \, dx$ (c) $\int (1 + \cot^2 2x) \cot^2 2x \, dx$

Solution:

(a)
$$\int 1 + \tan^2 \pi x \, dx = \int \sec^2(\pi x) \, dx$$

$$= \frac{1}{\pi} \tan(\pi x) + C$$

$1 + \tan^2 A = \sec^2 A$

(b)
$$\int (1 + \tan^2 x) \tan^3 x \, dx = \int \sec^2 x (\tan x)^3 \, dx$$

$$= \frac{1}{4} \tan^4 x + C$$

$\int f'(x) \cdot [f(x)]^n \, dx$ $= \frac{[f(x)]^{n+1}}{n+1} + C$
--

(c)
$$\int (1 + \cot^2 2x) \cot^2 2x \, dx = \frac{1}{-2} \int -2 \operatorname{cosec}^2 2x (\cot 2x)^2 \, dx$$

$$= \frac{1}{-2} \times \frac{(\cot 2x)^3}{3} + C$$

$$= -\frac{1}{6} \cot^3 2x + C$$

Exercise 13.4 *To be completed without the use of a calculator.*

1. Integrate each of the following with respect to the appropriate variable:

(a) $\cos(2x)$

(b) $2 \sin(1 - 2t)$

(c) $\sec^2(1 + 2x)$

(d) $\tan(\pi x)$

(e) $2 \operatorname{cosec}^2\left(\frac{4t}{3}\right)$

(f) $\frac{3 \cot 3x}{2}$

(g) $\frac{\sqrt{2}}{\sin^2(1 + \pi t)}$

(h) $\frac{5 + \cos^2(\pi x + 1)}{3 \cos^2(\pi x + 1)}$

(i) $\frac{-2 + \sin^2(\pi x)}{3 \sin^2(\pi x)}$

2. Integrate each of the following with respect to x :

(a) $5 \sin^2(2x) \cos^4(2x)$

(b) $\cos(1 - x) \sin^3(1 - x)$

(c) $3 \sec^2(x) \tan(x)$

(d) $\operatorname{cosec}(x) \cot^3(x)$

(e) $\cos x (1 + \sin x)^3$

(f) $\sin 2x \sqrt{1 - 2 \cos 2x}$

(g) $\operatorname{cosec}^2 x (1 + \cot x)^3$

(h) $\frac{\sec^2 x}{\sqrt{1 + \tan x}}$

(i) $\frac{\operatorname{cosec}^2 2x}{(1 + \cot 2x)^4}$

3. Integrate each of the following with respect to x :

(a) $\frac{\cos(2\pi x)}{1 - \sin(2\pi x)}$

(b) $\frac{\sin(2x + 1)}{1 + \cos(2x + 1)}$

(c) $\frac{\cos(2x) + \sin(2x)}{\cos(2x) - \sin(2x)}$

(d) $\frac{\sec^2(x)}{1 + 2 \tan(x)}$

(e) $\frac{3 \operatorname{cosec}^2(2x)}{1 + 2 \cot(2x)}$

(f) $\frac{\cos(x) e^{\sin(x)}}{1 - 2e^{\sin(x)}}$

4. Anti-differentiate each of the following with respect to x :

$$\begin{array}{lll} \text{(a)} \sin(2x) \cos(2x) & \text{(b)} \cos(2x) \sin(4x) & \text{(c)} \cos^2 x - \sin^2 x \\ \text{(d)} 1 - 2 \sin^2 2x & \text{(e)} \frac{\cos(2x)}{\sin(x) \cos(x)} & \text{(f)} \frac{\sin^2 x + \cos^2 x}{2 \cos^2 x} \end{array}$$

5. Anti-differentiate each of the following with respect to x :

$$\begin{array}{lll} \text{(a)} 1 + \tan^2 2x & \text{(b)} (1 + \tan^2 2x) \tan^4 2x & \text{(c)} (1 + \tan^2 x) \sqrt{1 + \tan x} \\ \text{(d)} \frac{1 + \tan^2 x}{(1 + 2 \tan x)^3} & \text{(e)} \frac{1 + \tan^2 2x}{\sqrt{\pi + \tan 2x}} & \text{(f)} \frac{1 + \tan^2 x}{3 - 2 \tan x} \end{array}$$

6. Anti-differentiate each of the following with respect to x :

$$\begin{array}{lll} \text{(a)} 1 + \cot^2 2x & \text{(b)} (1 + \cot^2 \pi x) \cot^4 \pi x & \text{(c)} (1 + \cot^2 x) \sqrt{1 + \cot x} \\ \text{(d)} \frac{1 + \cot^2 x}{(1 - \cot x)^4} & \text{(e)} \frac{1 + \cot^2 x}{\sqrt{4 + 3 \cot x}} & \text{(f)} \frac{1 + \cot^2 x}{2 + \cot x} \end{array}$$

7. Determine the integral of each of the following, with respect to x :

$$\begin{array}{ll} \text{(a)} \sin(3x) \cos(2x) - \cos(3x) \sin(2x) & \text{(b)} \cos(4x) \cos(x) + \sin(4x) \sin(x) \\ \text{(c)} \sin(\pi/6) \cos(\pi x) + \cos(\pi/6) \sin(\pi x) & \text{(d)} \frac{\tan(x) + \tan(2x)}{1 - \tan(x) \tan(2x)} \end{array}$$

8. Determine:

$$\begin{array}{lll} \text{(a)} \int 1 d(\cos x) & \text{(b)} \int \sin x d(\sin x) & \text{(c)} \int \tan(\sqrt{x}) d(\sqrt{x}) \end{array}$$

13.5 Integration of Trigonometric Functions in General

- In integrating trigonometric functions, quite frequently, the use of trigonometric identities is required.

13.5.1 Even powers of $\sin(ax + b)$ and $\cos(ax + b)$

- The double angle cosine formula is used to successively reduce the even power of the sine/cosine function to a unit powered term involving a multiple angle. The unit powered multiple angled term can then be integrated without difficulty.

$$\begin{array}{l} \bullet \cos^2 A = \frac{1 + \cos 2A}{2} \\ \bullet \sin^2 A = \frac{1 - \cos 2A}{2} \end{array}$$

Example 13.11

Find the anti-derivative with respect to x for: (a) $\sin^2(2x)$ (b) $\cos^4(x)$.

Solution:

$$(a) \quad \sin^2(2x) = \frac{1 - \cos(4x)}{2}$$

$$\text{Hence} \quad \int \sin^2(2x) dx = \frac{1}{2} \int 1 - \cos(4x) dx$$

$$\frac{1}{2} \left[x - \frac{\sin(4x)}{4} \right] + C$$

$$(b) \quad \cos^4(x) = [\cos^2(x)]^2$$

$$= \left[\frac{1 + \cos(2x)}{2} \right]^2 \quad \text{I}$$

$$= \frac{1}{4} [1 + 2\cos(2x) + \cos^2(2x)]$$

$$= \frac{1}{4} \left[1 + 2\cos(2x) + \frac{1 + \cos(4x)}{2} \right] \quad \text{II}$$

$$= \frac{1}{4} \left[\frac{3}{2} + 2\cos(2x) + \frac{1}{2}\cos(4x) \right]$$

$$\text{Hence:} \quad \int \cos^4(x) dx = \frac{1}{4} \left[\frac{3x}{2} + \sin(2x) + \frac{1}{8}\sin(4x) \right] + C$$

Notes:

- Note that the double angle formula was used twice, once in statement [1] and again in statement [2] to successively bring the power of the cosine term from 4 down to 1.
- Clearly the method becomes inefficient when the power is large. In such instances a reduction formula is used. This, however, is outside the scope of this book.

13.5.2 Odd powers of $\sin(ax + b)$ and $\cos(ax + b)$

- For integrals involving odd powers of $\sin(ax + b)$ or $\cos(ax + b)$:
 - the odd powered integrand is separated into an even powered term and a term of power one
 - the term with the even power is rewritten in terms of the complementary trigonometric function using the identity $\sin^2 A + \cos^2 A = 1$
 - the resulting expression is then integrated using the formula

$$\int f'(x) \cdot [f(x)]^n dx = \frac{[f(x)]^{n+1}}{n+1} + C.$$

- Alternatively, a substitution method may be used. This will be discussed in the Section 13.5.

Example 13.12 See Example 13.15

Find the anti-derivative of $\cos^5 3x$, with respect to x .

Solution:

$$\begin{aligned} \text{Rewrite } \cos^5 3x &\equiv \cos 3x \cos^4 3x \\ &\equiv \cos 3x (\cos^2 3x)^2 \\ &\equiv \cos 3x (1 - \sin^2 3x)^2 \\ &\equiv \cos 3x (1 - 2\sin^2 3x + \sin^4 3x) \\ &\equiv \cos 3x - 2\cos 3x \sin^2 3x + \cos 3x \sin^4 3x \end{aligned}$$

Hence:

$$\begin{aligned} \int \cos^5 3x dx &= \int \cos 3x - 2\cos 3x \sin^2 3x + \cos 3x \sin^4 3x dx \\ &= \frac{\sin 3x}{3} - 2 \times \frac{1}{3} \int 3 \cos 3x (\sin 3x)^2 dx + \frac{1}{3} \int 3 \cos 3x (\sin 3x)^4 dx \\ &= \frac{\sin 3x}{3} - 2 \times \frac{1}{3} \left[\frac{(\sin 3x)^3}{3} \right] + \frac{1}{3} \left[\frac{(\sin 3x)^5}{5} \right] + C \\ &= \frac{1}{3} \left[\sin 3x - \frac{2\sin^3 3x}{3} + \frac{\sin^5 3x}{5} \right] + C \end{aligned}$$

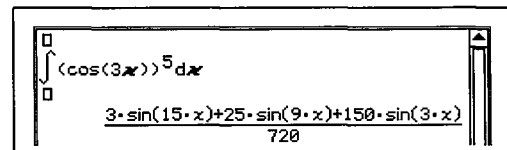

A screenshot of a CAS calculator interface showing the integral of $(\cos(3x))^5 dx$. The result is displayed as $\frac{3 \cdot \sin(15 \cdot x) + 25 \cdot \sin(9 \cdot x) + 150 \cdot \sin(3 \cdot x)}{720}$.

Note:

- For trigonometric integrals, depending on the technique used, several equivalent answers are possible.
- The accompanying screen-dump from a CAS calculator gives the solution in terms of sines of multiple angles, instead of powers of sines.

13.5.3 Integrals of $\sin^n(ax + b) \cos^m(ax + b)$

- If n and m are both even, then the double angle formula is used to reduce both powers to unitary.
- If at least one of n and m is odd, use the method described for odd powers to “split” the odd powered term.

Example 13.13

Integrate each of the following with respect to x : (a) $\sin^2 x \cos^2 x$ (b) $\sin^2 x \cos^3 x$.

Solution

(a) Identity: $\sin x \cos x = \frac{\sin 2x}{2}$

Hence,
$$\begin{aligned} \sin^2 x \cos^2 x &\equiv \left(\frac{\sin 2x}{2}\right)^2 \\ &\equiv \frac{1}{4} \sin^2 2x \\ &\equiv \frac{1}{4} \left(\frac{1 - \cos 4x}{2}\right) \\ &\equiv \frac{1}{8} (1 - \cos 4x) \end{aligned}$$

Therefore:

$$\begin{aligned} \int \sin^2(x) \cos^2(x) dx &= \frac{1}{8} \int 1 - \cos 4x dx \\ &= \frac{1}{8} \left(x - \frac{\sin 4x}{4} \right) + C \end{aligned}$$

$$\int (\sin(x))^2 (\cos(x))^2 dx = \frac{4x - \sin(4x)}{32} + C$$

(b) Rewrite:
$$\begin{aligned} \sin^2 x \cos^3 x &\equiv \sin^2 x \cos^2 x \cos x \\ &\equiv \sin^2 x (1 - \sin^2 x) \cos x \\ &\equiv \cos x \sin^2 x - \cos x \sin^4 x \end{aligned}$$

Hence:

$$\begin{aligned} \int \sin^2(x) \cos^3(x) dx &= \int \cos x \sin^2 x - \cos x \sin^4 x dx \\ &= \frac{\sin^3 x}{3} - \frac{\sin^5 x}{5} + C \end{aligned}$$

$$\int (\sin(x))^2 (\cos(x))^3 dx = -\frac{(\sin(x))^5}{5} + \frac{(\sin(x))^3}{3} + C$$

Exercise 13.5 *To be completed without the use of a calculator.*

1. Integrate the following with respect to the appropriate variable:

- | | | |
|----------------------|-----------------------|-------------------------|
| (a) $\sin^2(4x)$ | (b) $\sin^4(\pi x)$ | (c) $\cos^2(1-2t)$ |
| (d) $\cos^2(2\pi x)$ | (e) $\sin^3(2\pi t)$ | (f) $\cos^3(\pi x/2)$ |
| (g) $\sin^5(\pi t)$ | (h) $\cos^3(1-\pi x)$ | (i) $\sin^5(1-\pi x/2)$ |

2. Integrate the following with respect to the appropriate variable:

- | | | |
|-----------------------------------|-------------------------------------|-----------------------------------|
| (a) $\sin(\pi t) \cos(\pi t)$ | (b) $\sin^2(\pi x/2) \cos(\pi x/2)$ | (c) $\sin(3\pi x) \cos^2(3\pi x)$ |
| (d) $2 \sin^5(\pi x) \cos(\pi x)$ | (e) $\sin^2(x/2) \cos^2(x/2)$ | (f) $\sin^2(\pi t) \cos^3(\pi t)$ |
| (g) $\sin^3(2x) \cos^2(2x)$ | (h) $[\sin(x)]/\cos^2(x)$ | (i) $[\cos(x)]/\sin^2(x)$ |

13.6 Integration using the Method of Substitution/Change of variable

- What follows is a formal development of the method of substitution.

- Let $y = \int f(x) dx$. [1]

Since differentiation is the reverse of anti-differentiation: $\frac{dy}{dx} = f(x)$.

- Assume $x = g(u)$.

That is, assume that x can be written in terms of another variable u .
Hence, y can be expressed in terms of the variable u .

- Using the chain rule, $\frac{dy}{du} = \frac{dy}{dx} \times \frac{dx}{du}$.

Hence, $\frac{dy}{du} = f(x) \times \frac{dx}{du}$.

Anti-differentiate with respect to u : $y = \int f(x) \cdot \frac{dx}{du} du$ [2]

- Compare [1] with [2]: $\int f(x) dx = \int f(x) \cdot \frac{dx}{du} du$ [3]

- As $x = g(u)$, we can write $f(x) \equiv h(u)$.

Hence, [3] becomes: $\int f(x) dx = \int h(u) \cdot \frac{dx}{du} du$ [4]

- What we have done in [4] is to convert an integral with x as the variable to an integral with u as the variable. This procedure is known as integration with a change of variable or integration using a substitution.

- We shall now discuss a more “mechanical” approach to the method.
- Consider the expression $f(g(x)) \times g'(x)$.
- Let $u = g(x) \Rightarrow \frac{du}{dx} = g'(x)$.

From first principles:

$$\begin{aligned}
 g'(x) &= \lim_{\delta x \rightarrow 0} \left[\frac{g(x + \delta x) - g(x)}{\delta x} \right] \\
 &= \lim_{\delta x \rightarrow 0} \left[\frac{\delta u}{\delta x} \right] \\
 &\approx \frac{\delta u}{\delta x} \\
 &\Rightarrow \delta u \approx g'(x) \times \delta x
 \end{aligned}$$

This can be expressed as $du = g'(x) \times dx$.
 du and dx are referred to as differentials.

- That is, if $\frac{du}{dx} = g'(x) \Rightarrow du = g'(x) \times dx$.
- Anti-differentiate $f(g(x)) \times g'(x)$ with respect to x :

$$\int f(g(x)) \times g'(x) dx.$$

In the integral:

- replace $f(g(x))$ with $f(u)$
- replace $g'(x) \times dx$ with du .

Hence: $\int f(g(x)) \times g'(x) dx \equiv \int f(u) du$ where $u = g(x)$.

- In this approach, we have “violated” the idea that $\frac{du}{dx}$ is a symbol by itself, and $\int f(g(x)) \times g'(x) dx$ is another symbol by itself.

However, in this instance, it is formally acceptable by the mathematical community.

- The symbols, dy , dx , du etc. are considered as *differentials* and hence can be manipulated as algebraic terms.

Example 13.14

Integrate the following with respect to x using the suggested substitution:

(a) $\left(\frac{x-1}{x+1}\right)^2$ $u = x + 1$ (b) $x\sqrt{1-x^2}$ $u = (1-x^2)$

Solution:

(a) $u = x + 1 \Rightarrow \frac{du}{dx} = 1 \Rightarrow dx = du.$

Also, $\left(\frac{x-1}{x+1}\right)^2 \equiv \left(\frac{u-2}{u}\right)^2$

Hence:
$$\begin{aligned} \int \left(\frac{x-1}{x+1}\right)^2 dx &= \int \left(\frac{u-2}{u}\right)^2 du \\ &= \int 1 - \frac{4}{u} + 4u^{-2} du \\ &= u - 4\ln|u| - \frac{4}{u} + C \\ &= (x+1) - \frac{4}{(x+1)} - 4\ln|(x+1)| + C \\ &= x - \frac{4}{(x+1)} - 4\ln|(x+1)| + K \end{aligned}$$

(b) $u = 1 - x^2 \Rightarrow du = -2x dx \Rightarrow dx = -\frac{1}{2x} du$

Also $x\sqrt{1-x^2} \equiv xu^{\frac{1}{2}}$

Hence
$$\begin{aligned} \int x\sqrt{1-x^2} dx &= \int xu^{\frac{1}{2}} \times -\frac{1}{2x} du \\ &= -\frac{1}{2} \int u^{\frac{1}{2}} du \\ &= -\frac{u^{\frac{3}{2}}}{\frac{3}{2}} + C \\ &= -\frac{(1-x^2)^{\frac{3}{2}}}{3} + C \end{aligned}$$

It is not necessary to convert the integrand completely to an expression in u . With "foresight" the remaining " x " term will be eliminated in the steps that follow.

- The algorithm then becomes:
 1. Find the differential equivalent to dx .
 2. Convert $f(x)$ into an expression $h(u)$ involving the new variable u .
This does not have to be a complete conversion. .
 3. Integrate $h(u)$ with respect to the new differential.
 4. Express the final answer in terms of x .

Example 13.15 See Example 13.12

 Use the substitution $u = \sin 3x$ to find the anti-derivative of $\cos^5 3x$, with respect to x .

Solution:

$$u = \sin 3x \Rightarrow du = 3 \cos 3x dx \Rightarrow dx = \frac{1}{3 \cos 3x} du$$

$$\begin{aligned} \text{Also, } \cos^5 3x &\equiv \cos 3x \cos^4 3x \\ &\equiv \cos 3x (\cos^2 3x)^2 \\ &\equiv \cos 3x (1 - \sin^2 3x)^2 \\ &\equiv \cos 3x (1 - 2 \sin^2 3x + \sin^4 3x) \\ &\equiv \cos 3x (1 - 2u^2 + u^4) \end{aligned}$$

Hence:

$$\begin{aligned} \int \cos^5 3x dx &= \int \cos 3x (1 - 2u^2 + u^4) \times \frac{1}{3 \cos 3x} du \\ &= \frac{1}{3} \int (1 - 2u^2 + u^4) du \\ &= \frac{1}{3} \left[u - \frac{2u^3}{3} + \frac{u^5}{5} \right] + C \\ &= \frac{1}{3} \left[\sin 3x - \frac{2 \sin^3 3x}{3} + \frac{\sin^5 3x}{5} \right] + C \end{aligned}$$

Exercise 13.6 To be completed without the use of a calculator.

 1. Integrate each of the following with respect to x using the suggested substitution:

(a) $(1 + 2x)^6$	$u = 1 + 2x$	(b) $\sqrt{1 - 2x}$	$u = 1 - 2x$
(c) $4x \sqrt{x^2 + 1}$	$u = x^2 + 1$	(d) $\sqrt{x(1 + x^{\frac{3}{2}})}$	$u = 1 + x^{\frac{3}{2}}$
(e) $\frac{2x}{\sqrt{9 - 4x^2}}$	$u = 9 - 4x^2$	(f) $\frac{2x^2}{\sqrt{x^3 - 8}}$	$u = x^3 - 8$

 2. Integrate each of the following with respect to x using the suggested substitution:

(a) $\sqrt{4 + \sqrt{x}}$	$u = 4 + \sqrt{x}$	(b) $x\sqrt{1+x}$	$u = 1 + x$
(c) $x^2 \sqrt{1-x}$	$u = 1 - x$	(d) $(x+1)^4 \sqrt{1+2x}$	$u = 1 + 2x$
(e) $\frac{x}{2x+1}$	$u = 2x + 1$	(f) $\frac{x^2 + 1}{(x+2)^2}$	$u = x + 2$
(g) $\frac{2x}{\sqrt{x+4}}$	$u = x + 4$	(h) $\frac{1}{2 + \sqrt{x}}$	$u = \sqrt{x}$

3. Integrate each of the following with respect to x using the suggested substitution:

- (a) $2x \cos(x^2)$ $u = x^2$ (b) $3x \sin(x^2 + 1)$ $u = x^2 + 1$
 (c) $x \sec(2x^2)$ $u = 2x^2$ (d) $4x \tan(x^2)$ $u = x^2$
 (e) $x \cos(2x^2 + 1)$ $u = 2x^2 + 1$ (f) $x^2 \sin(2 + x^3)$ $u = 2 + x^3$

4. Use an appropriate substitution to integrate the following with respect to x :

- (a) $\frac{(1+\sqrt{x})^3}{\sqrt{x}}$ (b) $\frac{[1+\ln(x)]^2}{x}$ (c) $\frac{x+2}{2x+3}$ (d) $\frac{x^2+x-1}{(1-x)^2}$
 (e) $\frac{x+1}{\sqrt{x+9}}$ (f) $\frac{x}{1+\sqrt{x}}$ (g) $x \sin(x^2)$ (h) $\frac{\cos(\sqrt{x})}{\sqrt{x}}$
 (i) $\frac{\sin\left[\frac{1}{x}\right]}{x^2}$ (j) $\frac{\cos(e^{-x})}{e^x}$ (k) $\frac{x}{\cos^2(x^2)}$ (l) $\frac{x^2}{\sin^2(x^3)}$

13.6.1 Integration using Trigonometric Substitutions

- In this section we will deal with integrals which are not necessarily trigonometric in form but using a substitution that is trigonometric in form.

Example 13.16

Find: $\int \frac{1}{\sqrt{1-x^2}} dx$ using the substitution $x = \sin(\theta)$.

Solution:

$$x = \sin \theta \Rightarrow dx = \cos \theta d\theta$$

$$\begin{aligned} \text{Also} \quad \frac{1}{\sqrt{1-x^2}} &= \frac{1}{\sqrt{1-\sin^2 \theta}} \\ &= \frac{1}{\cos \theta} \end{aligned}$$

$$\begin{aligned} \text{Hence,} \quad \int \frac{1}{\sqrt{1-x^2}} dx &= \int \frac{1}{\cos \theta} [\cos \theta d\theta] \\ &= \int 1 d\theta \\ &= \theta + C \\ &= \sin^{-1} x + C. \end{aligned}$$

Example 13.17

Find: $\int \sqrt{1-x^2} \, dx$ using the substitution $x = \sin(\theta)$.

Solution:

$$x = \sin \theta \Rightarrow dx = \cos \theta \, d\theta$$

$$\text{Also } \sqrt{1-x^2} = \sqrt{1-\sin^2 \theta} = \cos \theta$$

$$\begin{aligned} \text{Hence, } \int \sqrt{1-x^2} \, dx &= \int \cos^2 \theta \, d\theta \\ &= \frac{1}{2} \int 1 + \cos 2\theta \, d\theta \\ &= \frac{1}{2} \left[\theta + \frac{\sin 2\theta}{2} \right] + C \end{aligned}$$

$$\text{Since, } x = \sin \theta \Rightarrow \theta = \sin^{-1} x.$$

$$\begin{aligned} \text{Also, } \sin 2\theta &= 2 \sin \theta \cos \theta \\ &= 2 \sin \theta \sqrt{1-\sin^2 \theta} = 2x\sqrt{1-x^2} \end{aligned}$$

$$\text{Hence, } \int \sqrt{1-x^2} \, dx = \frac{1}{2} \left[\sin^{-1} x + x\sqrt{1-x^2} \right] + C.$$

Exercise 13.7 *To be completed without the use of a calculator.*

1. Integrate each of the following with respect to x , using the suggested substitution.

(a) $\frac{2x}{\sqrt{4-x^2}}$	$x = 2\sin \theta$	(b) $\frac{x}{\sqrt{9-4x^2}}$	$x = \frac{3}{2}\cos \theta$
(c) $\frac{1}{1+x^2}$	$x = \tan \theta$	(d) $\frac{1}{25+9x^2}$	$x = \frac{5}{3}\tan \theta$

2. Integrate each of the following with respect to x , using the suggested substitution.

(a) $\frac{1}{\sqrt{4-x^2}}$	$x = 2\cos \theta$	(b) $\frac{1}{\sqrt{9-4x^2}}$	$x = \frac{3}{2}\cos \theta$
(c) $\sqrt{1-x^2}$	$x = \sin \theta$	(d) $\sqrt{4-x^2}$	$x = 2\cos \theta$
(e) $\frac{x-1}{\sqrt{1-x^2}}$	$x = \sin \theta$	(f) $\frac{2x+1}{\sqrt{16-x^2}}$	$x = 4\cos \theta$

3. Integrate each of the following with respect to x , using the suggested substitution.

(a) $\frac{\tan^2 x}{\cos^4 x}$	$u = \tan(x)$	(b) $\frac{1}{\cos^2(x)\sqrt{3\tan(x)+2}}$, $u = 3\tan(x)+2$
---------------------------------	---------------	---

13.7 Integration using Partial Fractions

13.7.1 Proper Fractions

- A *proper fraction* is a rational function $\frac{A(x)}{B(x)}$ where the degree of the *denominator* is *greater* than the degree of the *numerator*.

For example, $\frac{x+2}{x^2+6x+5}$ is a proper fraction, while $\frac{x^2+2}{x^2+6x+5}$ and $\frac{x^3+2}{x^2+6x+5}$ are *improper fractions*.

- An improper fraction can be converted into an expression involving a proper fraction using polynomial division (other procedures are available).
 - If $\frac{A(x)}{B(x)}$ is an improper fraction, then using polynomial division,

$$\text{we can rewrite the fraction as: } \frac{A(x)}{B(x)} = Q(x) + \frac{R(x)}{B(x)},$$

where $Q(x)$ is the quotient,

$R(x)$ is the remainder which is of a lower degree than $B(x)$.

13.7.2 Partial Fractions

- Consider the sum of the proper fractions, $\frac{1}{x+1} + \frac{1}{x+2}$.
- After the addition is performed: $\frac{1}{x+1} + \frac{1}{x+2} \equiv \frac{2x+3}{(x+1)(x+2)}$.
- When the process is reversed, we rewrite $\frac{2x+3}{(x+1)(x+2)}$ as a sum of several simpler proper fractions.
That is, $\frac{2x+3}{(x+1)(x+2)} \equiv \frac{1}{x+1} + \frac{1}{x+2}$.
These simpler fractions are called *partial fractions*.
- The decomposition of a rational function into its partial fractions is determined by several rules.

Rule 1 Proper Fractions

Only proper fractions may be decomposed into its partial fractions.

- Hence, an improper fraction cannot be decomposed into its partial fractions.
- To decompose an improper fraction into its partial fractions, we first need to rewrite it into an expression involving proper fractions.

Rule 2 Unique linear factors

Corresponding to a linear factor $(ax + b)$ in the denominator of a proper fraction, there exists a partial fraction of the form $\frac{A}{ax + b}$ where A is a constant.

Example 13.18

Decompose into its partial fractions $\frac{x}{(x+1)(x-2)(2x-1)}$.

Hence, determine $\int \frac{x}{(x+1)(x-2)(2x-1)} dx$.

Solution:

$$\begin{aligned} \frac{x}{(x+1)(x-2)(2x-1)} &\equiv \frac{A}{x+1} + \frac{B}{x-2} + \frac{C}{2x-1} \\ &\equiv \frac{A(x-2)(2x-1) + B(x+1)(2x-1) + C(x+1)(x-2)}{(x+1)(x-2)(2x-1)} \end{aligned}$$

Hence $x \equiv A(x-2)(2x-1) + B(x+1)(2x-1) + C(x+1)(x-2)$

$$\begin{aligned} \text{Substitute } x = -1, \quad 9A = -1 &\Rightarrow A = -\frac{1}{9} \\ x = 2, \quad 9B = 2 &\Rightarrow B = \frac{2}{9} \\ x = \frac{1}{2} \quad -\frac{9}{4}C = \frac{1}{2} &\Rightarrow C = -\frac{2}{9} \end{aligned}$$

Therefore $\frac{x}{(x+1)(x-2)(2x-1)} \equiv \frac{-1}{9(x+1)} + \frac{2}{9(x-2)} - \frac{2}{9(2x-1)}$.

Hence:

$$\begin{aligned} \int \frac{x}{(x+1)(x-2)(2x-1)} dx &= \int \frac{-1}{9(x+1)} + \frac{2}{9(x-2)} - \frac{2}{9(2x-1)} dx \\ &= -\frac{1}{9} \ln|x+1| + \frac{2}{9} \ln|x-2| - \frac{1}{9} \ln|2x-1| + C \\ &= \frac{1}{9} \ln \left| \frac{(x-2)^2}{(x+1)(2x-1)} \right| + C. \end{aligned}$$

Note:

- Since the identity $x \equiv A(x-1)(2x-1) + B(x+1)(2x-1) + C(x+1)(x-2)$ is true for all values of x , we can determine the values of A , B and C by simply substituting several convenient values of x .

Rule 3 Repeated linear factors

Corresponding to a factor $(ax + b)^n$ in the denominator of a proper fraction, where n is a positive integer, there exists n partial fractions of the form:

$$\frac{A_1}{(ax+b)}, \frac{A_2}{(ax+b)^2}, \frac{A_3}{(ax+b)^3}, \dots, \frac{A_n}{(ax+b)^n}$$

where $A_1, A_2, A_3, \dots, A_n$ are constants.

Example 13.19

Decompose into its partial fractions $\frac{x}{(x+1)(x-1)^2}$. Hence, determine $\int \frac{x}{(x+1)(x-1)^2} dx$

Solution:

Applying Rules 2 and 3:

$$\begin{aligned} \frac{x}{(x+1)(x-1)^2} &\equiv \frac{A}{x+1} + \frac{B}{x-1} + \frac{C}{(x-1)^2} \\ &\equiv \frac{A(x-1)^2 + B(x+1)(x-1) + C(x+1)}{(x+1)(x-1)^2} \end{aligned}$$

Hence,
$$x \equiv A(x-1)^2 + B(x+1)(x-1) + C(x+1)$$

Substitute $x = -1$ $-1 = 4A$ $\Rightarrow A = -\frac{1}{4}$

$x = 1$ $1 = 2C$ $\Rightarrow C = \frac{1}{2}$

$x = 0$ $0 = A - B + C$ $\Rightarrow B = \frac{1}{4}$

Therefore:
$$\frac{x}{(x+1)(x-1)^2} \equiv \frac{-1}{4(x+1)} + \frac{1}{4(x-1)} + \frac{1}{2(x-1)^2}$$

Hence:

$$\begin{aligned} \int \frac{x}{(x+1)(x-1)^2} dx &= \int \frac{-1}{4(x+1)} + \frac{1}{4(x-1)} + \frac{1}{2(x-1)^2} dx \\ &= -\frac{1}{4} \ln|x+1| + \frac{1}{4} \ln|x-1| - \frac{1}{2(x-1)} + C \\ &= \frac{1}{4} \ln \left| \frac{(x-1)}{(x+1)} \right| - \frac{1}{2(x-1)} + C. \end{aligned}$$

Rule 4 Non-reducible quadratic factors

Corresponding to a non-reducible quadratic factor $ax^2 + bx + c$ in the denominator of a proper fraction, there exists a partial fraction of the form $\frac{Ax+B}{(ax^2+bx+c)}$.

where A and B are constants.

Example 13.20

Use partial fractions to determine $\int \frac{x+1}{(x-1)(x^2+1)} dx$.

Solution:

Applying Rules 1 & 4:

$$\begin{aligned} \frac{x+1}{(x-1)(x^2+1)} &\equiv \frac{A}{x-1} + \frac{Bx+C}{x^2+1} \\ &\equiv \frac{A(x^2+1) + (Bx+C)(x-1)}{(x-1)(x^2+1)} \end{aligned}$$

Hence, $x+1 \equiv A(x^2+1) + (Bx+C)(x-1)$

Substitute $x = 1$	$2 = 2A$	$\Rightarrow A = 1$
$x = 0$	$1 = A - C$	$\Rightarrow C = 0$
$x = 2$	$3 = 5A + 2B + C$	$\Rightarrow B = -1$

Therefore $\frac{x+1}{(x-1)(x^2+1)} \equiv \frac{1}{x-1} + \frac{-x}{x^2+1}$

Hence:

$$\begin{aligned} \int \frac{x+1}{(x-1)(x^2+1)} dx &= \int \frac{1}{x-1} - \frac{x}{x^2+1} dx \\ &= \ln|x-1| - \frac{1}{2} \ln|x^2+1| + C \\ &= \ln \left| \frac{x-1}{\sqrt{x^2+1}} \right| + C. \end{aligned}$$

Exercise 13.8 *To be completed without the use of a calculator.*1. Use partial fractions to integrate each of the following with respect to x :

(a) $\frac{x}{x+2}$

(b) $\frac{x+3}{2x+1}$

(c) $\frac{3x-1}{1-2x}$

2. Use partial fractions to integrate each of the following with respect to x :

(a) $\frac{1}{(x+1)(x-1)}$

(b) $\frac{x-1}{(2x+1)(x-3)}$

(c) $\frac{5x-1}{(3x+2)(2-x)}$

(d) $\frac{2x+1}{2x^2-5x+2}$

(e) $\frac{x^2-1}{(x+2)(x-3)}$

(f) $\frac{x-1}{(x+1)(x-3)(x+2)}$

3. Use partial fractions to integrate each of the following with respect to x :

(a) $\frac{x+1}{x(x-1)^2}$

(b) $\frac{2x-1}{x^2(x+1)}$

(c) $\frac{2x+1}{(x+1)^2(x+2)}$

(d) $\frac{x^3}{(x-1)^2(x+1)}$

(e) $\frac{(x+1)(x-1)}{(x^2-4)(x+2)}$

(f) $\frac{x^3+1}{x^3-6x^2+9x}$

4. Use partial fractions to integrate each of the following with respect to x :

(a) $\frac{x-1}{(x+1)(x^2+1)}$

(b) $\frac{x-1}{(x+1)(x^2+x+1)}$

(c) $\frac{3x^2-2}{(x-1)(x^2+x-1)}$

Addendum**Heaviside Cover-up Method for determining partial fractions involving linear factors**

$$\frac{1}{(y+1)(y+2)} = \frac{A}{y+1} + \frac{B}{y+2}$$

Use the Heaviside cover-up method: $A = \frac{1}{(y+2)} \Big|_{y=-1} = 1$

$$B = \frac{1}{(y+1)} \Big|_{y=-2} = -1.$$

14 Definite Integration

14.1 Integrals expressed as partial fractions

- The concept of definite integration was first introduced in Mathematics Methods Units 3 & 4.
- This section extends the concept of definite integration to integrals requiring the use of partial fractions.

Example 14.1

Without the use of a calculator, evaluate $\int_{-2}^{-1} \frac{x+1}{(x-1)(x-2)} dx$.

Solution:

$$\text{Integrand: } \frac{x+1}{(x-1)(x-2)} \equiv \frac{A}{x-1} + \frac{B}{x-2}$$

$$x+1 \equiv A(x-2) + B(x-1)$$

$$\text{Substitute } x=1 \qquad A = -2$$

$$\text{Substitute } x=2 \qquad B = 3.$$

$$\text{Hence: } \int_{-2}^{-1} \frac{x+1}{(x-1)(x-2)} dx = \int_{-2}^{-1} \frac{-2}{x-1} + \frac{3}{x-2} dx$$

$$= \left[-2 \ln|x-1| + 3 \ln|x-2| \right]_{-2}^{-1}$$

$$= \left[\ln \left| \frac{(x-2)^3}{(x-1)^2} \right| \right]_{-2}^{-1}$$

$$= \left[\ln \left| \frac{27}{4} \right| - \ln \left| \frac{-64}{9} \right| \right]$$

$$= \ln \left(\frac{243}{256} \right).$$

Exercise 14.1 *To be completed without the use of a calculator.*

1. Evaluate each of the following integrals.

$$(a) \int_2^3 \frac{1}{(x+1)(x-1)} dx \quad (b) \int_0^1 \frac{x-1}{(x+1)(x+2)} dx \quad (c) \int_{-2}^{-1} \frac{2x-1}{(x-1)(x-2)} dx$$

2. Evaluate each of the following integrals.

$$(a) \int_0^1 \frac{x^2}{(x+1)(x+2)} dx \quad (b) \int_1^2 \frac{2x^2+1}{2x^2-x} dx \quad (c) \int_0^1 \frac{x^3+6}{x^2+3x+2} dx$$

3. Evaluate each of the following integrals.

$$(a) \int_0^1 \frac{x^2-2}{(x+1)^2(x+2)} dx \quad (b) \int_2^3 \frac{x-2}{x^3+x^2-x-1} dx \quad (c) \int_2^3 \frac{x^3}{x^3-x^2-x+1} dx$$

4. Evaluate each of the following integrals.

$$(a) \int_2^3 \frac{5x^2-4x+1}{(x^2+1)(x-1)} dx \quad (b) \int_0^1 \frac{-3x^2-2x-9}{(x^2+x+2)(x+1)} dx \quad (c) \int_0^1 \frac{2x^3}{(x^2+2)(x^2+1)} dx$$

14.2 Method of Substitution

- This section extends the concept of definite integration to integration using the method of substitution.

- To evaluate $\int_a^b f(x) dx$ using the substitution $u = g(x)$:

1. Find the differential equivalent to dx .
2. Use the substitution to convert the limits from $x = a$ and $x = b$ into $u = k$ and $u = m$ respectively.
3. Convert $f(x)$ into an expression $h(u)$ involving the new variable u .
This does not have to be a complete conversion.
4. Integrate $h(u)$ with respect to the new differential.
5. Substitute limits to obtain answer.

Example 14.2

Evaluate each of the following using the suggested substitution:

$$(a) \int_0^1 x\sqrt{1-x} \, dx \quad u = 1 - x \quad (b) \int_0^1 \frac{1}{\sqrt{4-x^2}} \, dx \quad x = 2 \sin \theta.$$

Solution:

$$(a) \quad u = 1 - x \Rightarrow dx = -du.$$

$$\text{Limits:} \quad x = 0 \Rightarrow u = 1 \text{ and } x = 1 \Rightarrow u = 0.$$

$$\begin{aligned} \text{Hence:} \quad x \int_0^1 x\sqrt{1-x} \, dx &= -\int_1^0 (1-u)\sqrt{u} \, du \\ &= -\int_1^0 u^{\frac{1}{2}} - u^{\frac{3}{2}} \, du \\ &= -\left[\frac{2u^{\frac{3}{2}}}{3} - \frac{2u^{\frac{5}{2}}}{5} \right]_1^0 \\ &= \frac{4}{15} \end{aligned}$$

$$(b) \quad x = 2 \sin \theta \Rightarrow dx = 2 \cos \theta \, d\theta$$

$$\text{Limits: } x = 0 \Rightarrow \theta = 0 \text{ and } x = 1 \Rightarrow \sin(\theta) = 1/2 \Rightarrow \theta = \pi/6$$

$$\begin{aligned} \text{Hence:} \quad \int_0^1 \frac{1}{\sqrt{4-x^2}} \, dx &= \int_0^{\pi/6} \frac{1}{\sqrt{4-4\sin^2 \theta}} \times 2 \cos \theta \, d\theta \\ &= \int_0^{\pi/6} \frac{1}{\sqrt{4(1-\sin^2 \theta)}} \times 2 \cos \theta \, d\theta \\ &= \int_0^{\pi/6} \frac{1}{\sqrt{4\cos^2 \theta}} \times 2 \cos \theta \, d\theta \\ &= \int_0^{\pi/6} 1 \, d\theta \\ &= [\theta]_0^{\pi/6} \\ &= \frac{\pi}{6}. \end{aligned}$$

Exercise 14.2

1. Evaluate each of the following using an appropriate substitution:

$$(a) \int_0^1 \sqrt{2+\sqrt{x}} \, dx \quad (b) \int_0^1 \frac{1}{4-\sqrt{x}} \, dx \quad (c) \int_{-1}^0 \frac{4x}{2x-1} \, dx \quad (d) \int_5^6 \frac{x}{\sqrt{x-4}} \, dx$$

2. Evaluate each of the following using an appropriate substitution:

$$(a) \int_0^{\sqrt{\pi}} 2x \sin x^2 \, dx \quad (b) \int_0^{\frac{\sqrt{\pi}}{2}} 2x \sec^2(x^2) \, dx \quad (c) \int_0^{\frac{\pi}{2}} (\cos x)(\sin x) \, dx$$

3. Evaluate each of the following using an appropriate substitution:

$$(a) \int_0^{\frac{1}{4}} \frac{1}{\sqrt{1-4x^2}} \, dx \quad (b) \int_0^{\frac{1}{3}} \frac{1}{\sqrt{4-9x^2}} \, dx \quad (c) \int_0^{\frac{1}{2}} \sqrt{1-4x^2} \, dx$$

14.3 Area of Regions Trapped between Curves

- In this section, we will extend the concept of the area trapped between curves, first introduced in Mathematics Methods Units 3 & 4.
- If $f(x) \geq g(x)$ for $a \leq x \leq b$, the area of the region trapped between $y=f(x)$ and $y=g(x)$ and the lines $x=a$ and $x=b$ is given by:

$$A = \int_a^b f(x) - g(x) \, dx$$

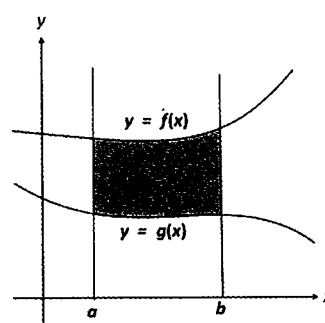

- Where the use of a CAS calculator is permitted: the area of the region trapped between the curves $y=f(x)$ and $y=g(x)$ and the lines $x=a$ and $x=b$ is given by

$$A = \int_a^b |f(x) - g(x)| \, dx.$$

- In this case, it is not necessary to locate the relative positions of the two curves.

Example 14.3

Without the use of a calculator, find the area trapped between the curves $y = x$, $y = \frac{1}{x}$ and the lines $x = \frac{1}{2}$ and $x = 2$.

Solution:

The curves $y = \frac{1}{x}$ and $y = x$ intersect at the point where $x = 1$.

For region A, $\frac{1}{2} \leq x \leq 1$, the $y = \frac{1}{x}$ curve is consistently “above” the $y = x$ curve.

Hence, the area of the trapped region is given by:

$$\begin{aligned} \text{Area (A)} &= \int_{\frac{1}{2}}^1 \frac{1}{x} - x \, dx \\ &= \left[\ln|x| - \frac{x^2}{2} \right]_{\frac{1}{2}}^1 \\ &= \left(\ln(1) - \frac{1}{2} \right) - \left(\ln \frac{1}{2} - \frac{1}{8} \right) = \ln 2 - \frac{3}{8} \end{aligned}$$

For region B, $1 \leq x \leq 2$, the $y = x$ curve is consistently “above” the $y = \frac{1}{x}$ curve.

Hence, the area of the trapped region is given by:

$$\begin{aligned} \text{Area (B)} &= \int_1^2 x - \frac{1}{x} \, dx \\ &= \left[\frac{x^2}{2} - \ln|x| \right]_1^2 \\ &= \left(2 - \ln(2) \right) - \frac{1}{2} = \frac{3}{2} - \ln 2 \end{aligned}$$

Hence, the area of the trapped region is:

$$\begin{aligned} \text{Area} &= \left(\ln 2 - \frac{3}{8} \right) + \left(\frac{3}{2} - \ln 2 \right) \\ &= \frac{9}{8} \text{ units}^2. \end{aligned}$$

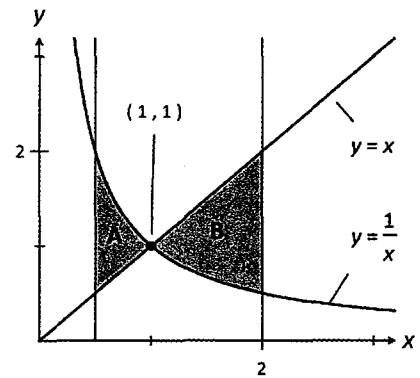

Exercise 14.3

Questions 1 to 4 (inclusive) are to be completed without the use of a calculator.

1. Determine the area of the region trapped between these two curves.

(a) $y = x(x - 1), y = x(3 - x)$

(b) $y = x^2 - 4, y = -3x^2$

(c) $y = x(x^2 - 1), y = 3x$

(d) $y = x^2, y = \sqrt{x}$

2. Find the area of the region trapped between the two given curves and the indicated lines.

(a) $y = -\frac{1}{x}, y = -x, x = -2$ and $x = -\frac{1}{2}$

(b) $y = x, y = x(x - 1), x = -1$, and $x = 1$

(c) $y = \sin(x), y = \cos(x), x = 0$ and $x = \frac{\pi}{2}$

(d) $y = e^{2x}, y = e^{-x}, x = 1$

3. Determine the area of the region trapped between these two curves.

(a) $y = |x + 1|, y = 1 - x^2$

(b) $y = -|x - 1|, y = 1 - x^2$

(c) $y = |x - 2|, y = \sqrt{x}$

(d) $y = |x - 1|, y = |x^2 - 1|$

4. Find the area of the region trapped by:

(a) $y = e^x, y = e^{-x}, y = e$

(b) $y = x - 2, x = 4 - y^2$

(c) $y = \frac{2x}{x+1}, y = x^2$

(d) $y = \frac{-x}{x+2}, y = 2 - x^2, x = 0, x = 1$.

*5. Determine the area of the region trapped by:

(a) $y = \sin x, y = -\frac{3}{\pi}x + 1$, the y -axis

(b) $y = \cos x, y = \frac{3}{4\pi}x - 1$, the y -axis

6. The shaded region in the accompanying diagram is

bounded by the curve, $y = \frac{x}{(x-4)(x+4)}$ and the lines

$y = -x, x = -1$ and $x = 2$. Use a calculus method to find the area of the shaded region.

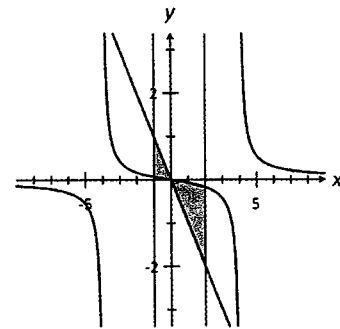

7. The shaded region in the accompanying diagram is

bounded by the curve, $y = \frac{4x^2}{(x-4)(x+4)}$ and the lines

$y = -x, x = -2$ and $x = 2$. Use a calculus method to find the area of the shaded region.

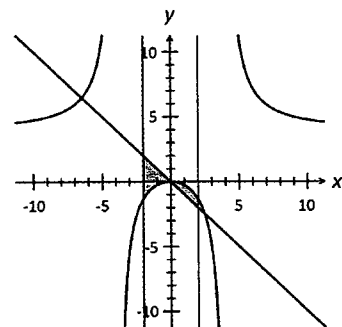

8. The shaded region in the accompanying diagram is bounded by the curve $y = \frac{1}{\sqrt{16-x^2}}$ and the lines $y = 2$ and $x = \pm 2$. Use a calculus method to find the area of the shaded region.

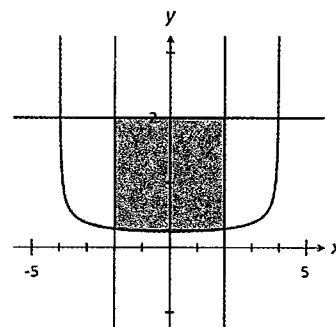

9. The shaded region in the accompanying diagram is bounded by the curve $y = \sqrt{9-4x^2}$ and x -axis. Use a calculus method to find the area of the shaded region.

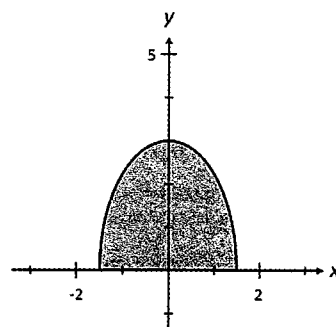

10. Use your CAS calculator to determine the area of the region trapped between the following curves:
- | | |
|-------------------------------------|---|
| (a) $y = 2 + \cos x, y = x, x = 0$ | (b) $y = 2 + \cos(x), y = x, x = -2$ |
| (c) $y = 2 + \sin(x)$ and $y = x^2$ | (d) $y = 2 + \sin(x), y = x^2, x = 4$. |
11. Use your CAS calculator to determine the area of the region trapped between the following curves:
- | | |
|--|---|
| (a) $y = x e^{-x^2}, y = 0, x = \pm 1$ | (b) $y = x \cos(x^2), y = 0, x = \pm 1$ |
| (c) $y = x \ln x, y = 0, x = 0.5, x = 2$ | (d) $y = \cos x e^{\sin x}, y = 0, x = \pm 1$ |

- *12. Use your CAS calculator to determine the area of the region trapped between the following curves:
- | | |
|---------------------------------------|------------------------------|
| (a) $x = y^2, x = 4$ | (b) $x = y^2, x + y - 2 = 0$ |
| (c) $y^2 - 4x = 0, y^2 + 4x - 16 = 0$ | (d) $x = y, x = 2 - y$ |

- *13. Find the area of the region trapped between $y = x^3$, $y = 3x - 2$ and the lines $x = -3$ and $x = b$ for:
- | |
|-------------------|
| (a) $-3 < b < -2$ |
| (b) $-2 < b < 1$ |
| (c) $b > 1$. |

14.4 Volume of Revolution

14.4.1 About the x -axis

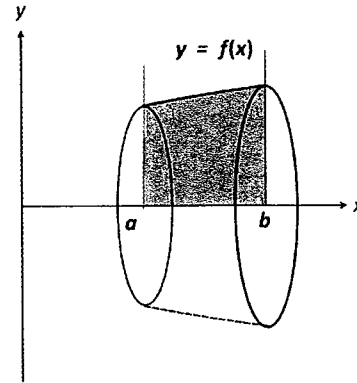
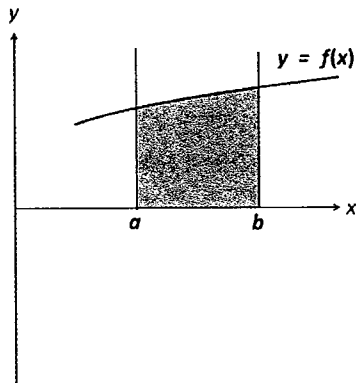

- Consider the region trapped by the curve $y = f(x)$, the x -axis and the lines $x = a$ and $x = b$.
 - If this region is rotated 360° about the x -axis, then a *solid of revolution* is formed.
 - In this case, the shape of the solid is somewhat similar to that of a “flower pot”.

- To determine the volume of the solid formed, let the shaded region be divided into n rectangular strips of height $f(x)$ and of uniform width δx .

- Each strip is rotated 360° about the x -axis, forming a stack of circular cylindrical discs of radius $f(x)$ and length dx .
 - The volume of a disc is $\pi[f(x)]^2 \delta x$.
- The solid of revolution formed is approximated by a stack of circular cylindrical discs.
- Hence volume of solid formed is

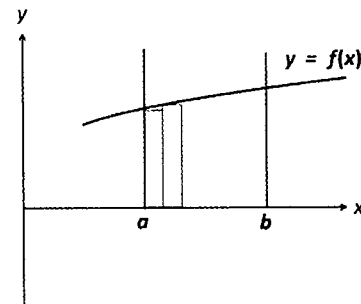

$$V \approx \lim_{\delta x \rightarrow 0} \sum_{x=a}^{x=b} \pi[f(x)]^2 \delta x = \pi \int_a^b [f(x)]^2 dx$$

increment δx

- Hence, the volume of solid formed when the region trapped by the curve $y = f(x)$, the x -axis, $x = a$ and $x = b$ is rotated 2π radians about the x -axis is given by:

$$V = \pi \int_a^b [f(x)]^2 dx$$

- Note that in the formula for V , the $f(x)$ term is squared. Hence, it is not essential that the curve $y = f(x)$ be completely above the x -axis for $a \leq x \leq b$.

Example 14.4

Determine the volume of the solid formed when the region trapped between the curve $y = x^2 - 1$, the x -axis, y -axis and the line $x = 2$ is rotated 2π radians about the x -axis.

Solution:

$$\begin{aligned} \text{Volume} &= \pi \int_0^2 (x^2 - 1)^2 dx = \pi \int_0^2 x^4 - 2x^2 + 1 dx \\ &= \pi \left[\frac{x^5}{5} - \frac{2x^3}{3} + x^2 \right]_0^2 \\ &= \frac{46\pi}{15} \text{ units}^3. \end{aligned}$$

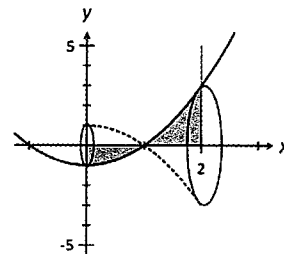
14.4.2 About the y-axis

- Similarly, the volume of the solid formed when the region trapped by the curve $x = f(y)$, the y -axis and the lines $y = a$ and $y = b$ is rotated about the y -axis, is given by:

$$V = \pi \int_a^b [f(y)]^2 dy$$

- Note that the equation of the curve must be written in the form $x = f(y)$ and y is the variable of the integral.

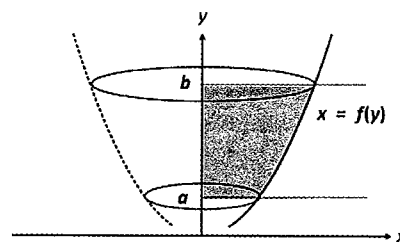
Example 14.5

Determine the volume of the solid formed when the region trapped between the curve $y = \frac{4}{x+2}$, the y -axis, and the lines $y = 1$ and $y = 4$ is rotated about the y -axis.

Solution:

$$\begin{aligned} y = \frac{4}{x+2} &\Rightarrow x+2 = \frac{4}{y} \Rightarrow x = \frac{4}{y} - 2 \\ \text{Volume } V &= \pi \int_1^4 \left(\frac{4}{y} - 2 \right)^2 dy = \pi \int_1^4 \frac{16}{y^2} - \frac{16}{y} + 4 dy \\ &= \pi \left[-\frac{16}{y} - 16 \ln|y| + 4y \right]_1^4 \\ &= 24\pi - 32\pi \ln 2 \text{ units}^3. \end{aligned}$$

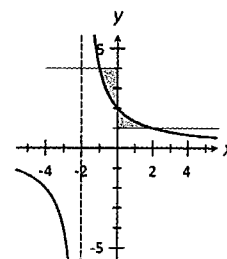

14.4.3 Volume generated by region trapped between two curves

- Consider $f(x) \geq g(x)$ for $a \leq x \leq b$. The region trapped between $y = f(x)$ and $y = g(x)$ and the lines $x = a$ and $x = b$ is rotated about the x -axis. The volume of the solid formed is obtained by subtraction and is given by:

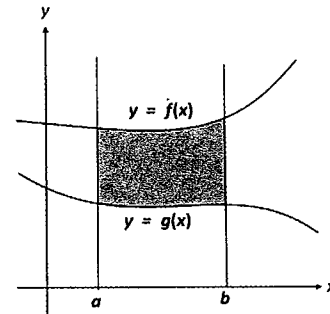

$$V = \text{Volume of larger Solid} - \text{Volume of smaller Solid}$$

$$= \pi \int_a^b [f(x)]^2 dx - \pi \int_a^b [g(x)]^2 dx$$

$$= \pi \int_a^b [f(x)]^2 - [g(x)]^2 dx$$

- Where the use of a CAS calculator is permitted, the volume of the solid created is given by:

$$V = \int_a^b \left| [f(x)]^2 - [g(x)]^2 \right| dx.$$

- In this case, it is not necessary to locate the relative positions of the two curves.
- Caution must be exercised when rotating regions trapped between two curves. It is possible that on rotation, one part of the solid formed may disappear into a larger part.

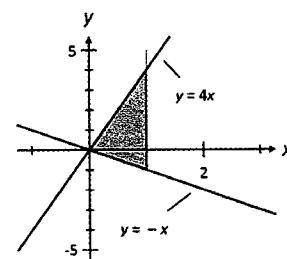

- In the accompanying diagram, when the shaded region is rotated about the x -axis, the solid formed by the triangle below the x -axis (smaller triangle) is “swallowed” up by the solid formed by the triangle above the x -axis (larger triangle).

Example 14.6

Determine the volume of the solid formed when the region trapped between the curves $y = x$, $y = \frac{1}{x}$ and the lines $x = \frac{1}{2}$ and $x = 2$ is rotated about the x -axis.

Solution:

For region A, $\frac{1}{2} \leq x \leq 1$, the $y = \frac{1}{x}$ curve is consistently “above” the $y = x$ curve.

$$\begin{aligned} \text{Hence, } V_A &= \pi \int_{\frac{1}{2}}^1 \left(\frac{1}{x}\right)^2 dx - \pi \int_{\frac{1}{2}}^1 x^2 dx \\ &= \pi \int_{\frac{1}{2}}^1 \left(\frac{1}{x}\right)^2 - x^2 dx \\ &= \pi \left[\frac{-1}{x} - \frac{x^3}{3} \right]_{\frac{1}{2}}^1 = \frac{17\pi}{24} \end{aligned}$$

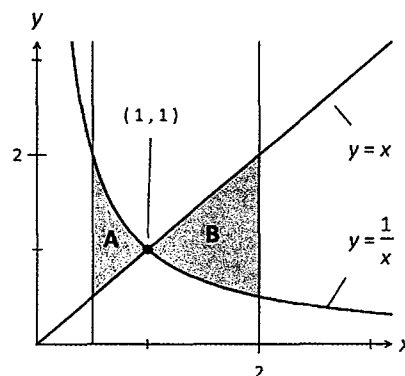

For region B, $1 \leq x \leq 2$, the $y = x$ curve is consistently “above” the $y = \frac{1}{x}$ curve.

$$\begin{aligned} \text{Hence, } V_B &= \pi \int_1^2 x^2 dx - \pi \int_1^2 \left(\frac{1}{x}\right)^2 dx \\ &= \pi \int_1^2 x^2 - \left(\frac{1}{x}\right)^2 dx \\ &= \pi \left[\frac{x^3}{3} - \frac{-1}{x} \right]_1^2 = \frac{11\pi}{6} \end{aligned}$$

Hence, the volume of the solid formed is: $V = V_A + V_B = \frac{61\pi}{24} \text{ units}^3$.

Note:

- With a CAS calculator, this volume is given by

$$V = \pi \int_{\frac{1}{2}}^2 \left| \frac{1}{x^2} - x^2 \right| dx .$$

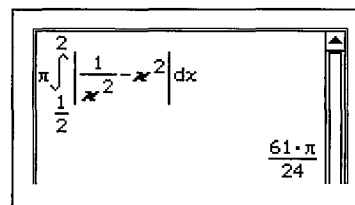

Exercise 14.4

- Without the use of a calculator, find the volume of the solid formed when the region trapped between the curve $y = f(x)$ and the line $y = 0$ is rotated about the x -axis.

(a) $y = x(2 - x)$	(b) $y = x^2 - 4$
(c) $y = x(x + 2)$	(d) $y = x^2(x - 1)$
(e) $y = \sin(x) \quad 0 \leq x \leq 2\pi$	(f) $y = \cos(x/2) \quad -\pi \leq x \leq \pi$

- Find the volume of the solid generated when the region trapped between the given curve, the x -axis and the indicated lines is rotated about the x -axis.

(a) $y = x(x - 1); x = -1, x = 1$	(b) $y = (x + 2)(x - 3); x = -1, x = 4$
(c) $y = (1 - x)(x + 3); x = -4, x = 2$	(d) $y = (x + 1)(x + 2)(x - 1); x = -2.5, x = 1$
(e) $y = -2 + e^x; x = -1, x = 2$	(f) $y = \ln(x); x = 1/2 \text{ and } x = e$
(g) $y = x ; x = -1 \text{ and } x = 2$	(h) $y = x(x - 1) ; x = -1 \text{ and } x = 1.$

- Find the volume of the solid generated when the region trapped between the given curve, the y -axis and the indicated line(s) is rotated 360° about the y -axis.

(a) $y = \frac{1}{x}; y = 1 \text{ and } y = 2$	(b) $y = \frac{2}{x+2}; y = 0.5 \text{ and } y = 3$
(c) $y = \frac{1}{1-x}; y = \frac{1}{2} \text{ and } y = 2$	(d) $y = \frac{1}{1-x}; y = -2 \text{ and } y = -1$
(e) $y = (x - 1)^2; y = 0 \text{ and } y = 1$	(f) $y = x^3 + 1; y = -1 \text{ and } y = 2$
(g) $x = \sqrt{9 - y^2}, x = 0$	(h) $y^3 = x^2, y = 4, x = 0$

- Find the volume of the solid generated when the region trapped between the two given curves and the indicated line(s) is rotated about the x -axis.

(a) $y = 3x, y = x^2, x = -1 \text{ and } x = 2$
(b) $y = x^2, y = x^3, x = 0 \text{ and } x = 2$
(c) $y = x^2 + 5, y = x^3, x = 0 \text{ and } x = 3$
(d) $y = \sin(x), y = \cos(x), x = 0 \text{ and } x = \pi/2$
(e) $y = e^{2x}, y = e^{-x}, x = 1$

15 Numerical Integration

15.1 Numerical Methods

- The Fundamental Theorem of Calculus was introduced in Mathematics Methods Units 3 & 4 and states that:

$$\int_a^b f(x) dx = F(b) - F(a) \quad \text{where } F(x) \text{ is an anti-derivative of } f(x).$$

- Consider $\int_0^1 e^{-x^2} dx$. In this instance, the Fundamental Theorem of Calculus fails as the anti-derivative of e^{-x^2} “does not exist”.
- The value of this definite integral and many others may however be approximated using *numerical methods*.
- Under certain conditions, a definite integral represents the area of a bounded region between the curve and the x -axis.

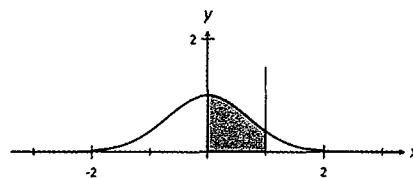

- $\int_0^1 e^{-x^2} dx$ represents the area of the region trapped between the curve, the x -axis and the lines $x = 0$ and $x = 1$.

- Numerical methods estimate the values of definite integrals by approximating the area of the regions using strips of uniform width. The accuracy of the approximations obtained depend on:
 - how many strips are used
 - how the strips are formed.

15.2 The Rectangular Rules

- The rectangular rules use rectangular strips to approximate the area of the trapped region. Among others, these strips may be drawn as left-boxes, right-boxes or middle-boxes.

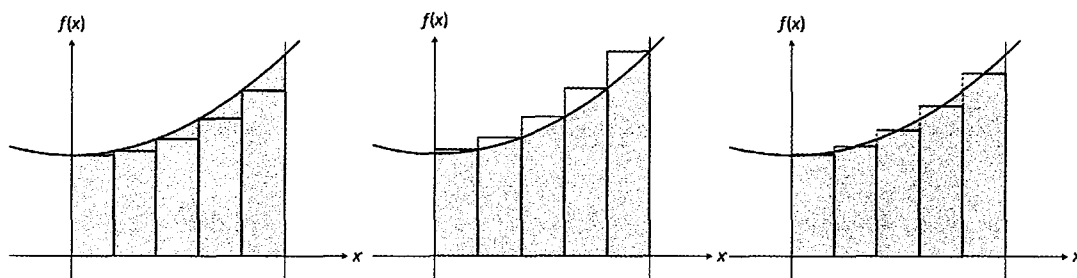

- Consider the curve $y = f(x)$ which is continuous over the interval $a \leq x \leq b$.
 - The trapped region R is divided in n rectangular strips (boxes) of uniform width.
 - Width of strip/box is $w = \frac{b-a}{n}$.
 - The *points of partition* on the x -axis or “edges” of the strips are located at $x_i = a + iw$ for $i = 0, 1, 2, \dots, n$.
- The Left Box Method
 - The area of a box $= w \times f(x_i)$
 - Hence, Area of R $= \sum_{i=0}^{n-1} w \times f(x_i) = w \times \sum_{i=0}^{n-1} f(x_i)$.
- The Right Box Method
 - The area of a box $= w \times f(x_{i+1})$
 - Hence, Area of R $= \sum_{i=0}^{n-1} w \times f(x_{i+1}) = w \times \sum_{i=0}^{n-1} f(x_{i+1})$.
- The Middle Box Method (Mid-point Method)
 - The area of a box $= w \times f\left(\frac{x_i + x_{i+1}}{2}\right)$
 - Hence, Area of R $= \sum_{i=0}^{n-1} \left[w \times f\left(\frac{x_i + x_{i+1}}{2}\right) \right] = w \times \sum_{i=0}^{n-1} f\left(\frac{x_i + x_{i+1}}{2}\right)$.
- The table below summarises the above results.

Left-box method	$w \times \sum_{i=0}^{n-1} f(x_i)$	Width of strip, $w = \frac{b-a}{n}$ Points of partition: $x_i = a + iw$ for $i = 0, 1, 2, \dots, n$.
Right-box method	$w \times \sum_{i=0}^{n-1} f(x_{i+1})$	
Middle-box/Mid-point Method	$w \times \sum_{i=0}^{n-1} f\left(\frac{x_i + x_{i+1}}{2}\right)$	

- Note that the three methods discussed use *different points of partitions*.
 - The region being investigated must be completely *above* or completely *below* the x -axis.
 - Of the three methods discussed, the middle-box or mid-point method is the preferred method.

Example 15.1

With a CAS calculator, use the mid-point method with 100 uniform strips to estimate the value of $\int_1^3 x(3-x) dx$. Estimate the percentage error.

Solution:

$\int_1^3 x(3-x) dx$ refers to the area of the region trapped between the curve $y = x(3-x)$, the x -axis and the lines $x = 1$ and $x = 3$. Further, this region is completely above the x -axis.

$$n = 100 \Rightarrow \text{width of strip} = \frac{3-1}{100} = 0.02$$

Points of partition $x_i = 1 + 0.02i$ for $i = 0, 1, 2, \dots, 100$.

$$\begin{aligned} \text{Area of strip} &= 0.02 \times f\left(\frac{x_i + x_{i+1}}{2}\right) \\ &= 0.02 \times f\left(\frac{(1 + 0.02i) + (1 + 0.02(i+1))}{2}\right) \\ &= 0.02 \times f(1.01 + 0.02i) \end{aligned}$$

$$\begin{aligned} \text{Hence, } \int_1^3 x(3-x) dx &\approx 0.02 \times \sum_{i=0}^{99} f(1.01 + 0.02i) \\ &\approx \frac{16667}{5000} = 3.3334. \end{aligned}$$

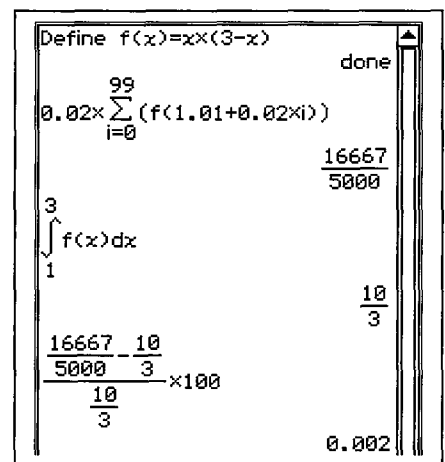

$$\text{But } \int_1^3 x(3-x) dx = \frac{10}{3} \Rightarrow \text{Error} = 0.022\%.$$

15.3 The Trapezium Rule

- The trapezium rule uses strips of uniform width in the shape of trapeziums to approximate the area of the trapped region. The trapezium rule averages the results of the left-box and right-box methods.
- Consider the curve $y = f(x)$ which is continuous over the interval $a \leq x \leq b$. Let number of strips be n .
 - Width of strip/box is $w = \frac{b-a}{n}$.

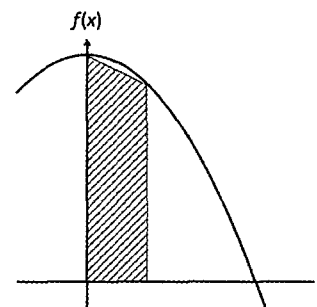

- The *points of partition* on the x -axis or “edges” of the strips are located at $x_i = a + iw$ for $i = 0, 1, 2, \dots, n$.

- The area of trapezoidal strip = $\frac{1}{2} \times [f(x_i) + f(x_{i+1})] \times w$
- Hence, Area = $\frac{w}{2} \times \sum_{i=0}^{n-1} [f(x_i) + f(x_{i+1})]$.

Example 15.2

With a CAS calculator, use the trapezium rule with 100 uniform strips to estimate the value of $\int_1^3 x(3-x) dx$. Estimate the percentage error.

Solution:

$\int_1^3 x(3-x) dx$ refers to the area of the region trapped between the curve $y = x(3-x)$, the x -axis and the lines $x = 1$ and $x = 3$. Further, this region is completely above the x -axis.

$$n = 100 \Rightarrow \text{width of strip} = \frac{3-1}{100} = 0.02$$

Points of partition $x_i = 1 + 0.02i$ for $i = 0, 1, 2, \dots, 100$.

$$\begin{aligned} \text{Area of strip} &= 0.01 \times [f(1 + 0.02i) + f(1 + 0.02(i + 1))] \\ &= 0.01 \times [f(1 + 0.02i) + f(1.02 + 0.02i)] \end{aligned}$$

Hence,

$$\begin{aligned} \int_1^3 x(3-x) dx &\approx 0.01 \times \sum_{i=0}^{99} [f(1 + 0.02i) + f(1.02 + 0.02i)] \\ &\approx \frac{8333}{2500} = 3.3332. \end{aligned}$$

$$\text{But } \int_1^3 x(3-x) dx = \frac{10}{3}.$$

Hence, error = -0.004% .

```

Define f(x)=x*(3-x)
done
0.01 * sum_{i=0}^{99} (f(1+0.02*i)+f(1.02+0.02*i))
8333
2500
3
10/3
8333/2500 - 10/3 * 100
10/3
-1/250

```

15.4 Simpson's Rule

- Simpson's rule uses an *even* number of strips of uniform width. The curved end of the strip is approximated by a parabola passing through the two edges of the strip and the midpoint of the strip.
- Consider the curve $y = f(x)$ which is continuous over the interval $a \leq x \leq b$.
 - Let number of strips be $2n$.
 - Width of strip/box is $w = \frac{b-a}{2n}$.
 - Points of partition $x_i = a + wi$ for $i = 0, 1, 2, \dots, 2n$.
 - It can be shown that the area is given by

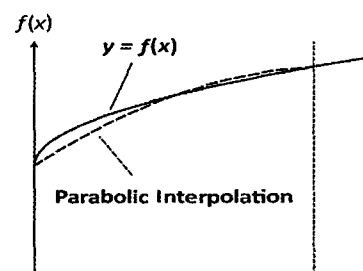

$$A = \left(\frac{b-a}{6n} \right) \times \left[f(a) + f(b) + 4 \sum_{i=0}^{n-1} f(x_{2i+1}) + 2 \sum_{i=1}^{n-1} f(x_{2i}) \right].$$

Example 15.3

With a CAS calculator, use Simpson's Rule with 100 uniform strips to estimate the value of $\int_1^3 e^x dx$. Estimate the percentage error.

Solution:

$\int_1^3 e^x dx$ refers to the area of the region trapped between the curve $y = e^x$, the x -axis and the lines $x = 1$ and $x = 3$. Further, this region is completely above the x -axis.

Number of strips $2n = 100 \Rightarrow n = 50$. Width of strip $= \frac{3-1}{100} = 0.02$.

Points of partition $x_i = 1 + 0.02i$ for $i = 0, 1, 2, \dots, 100$.

$$\begin{aligned} \int_1^3 e^x dx &\approx \left(\frac{b-a}{6n} \right) \times \left[f(a) + f(b) + 4 \sum_{i=0}^{n-1} f(x_{2i+1}) + 2 \sum_{i=1}^{n-1} f(x_{2i}) \right] \\ &\approx \left(\frac{3-1}{300} \right) \times \left[f(1) + f(3) + 4 \sum_{i=0}^{49} f(1 + 0.02(2i+1)) + 2 \sum_{i=1}^{49} f(1 + 0.02(2i)) \right] \\ &\approx \left(\frac{1}{150} \right) \times \left[f(1) + f(3) + 4 \sum_{i=0}^{49} f(1.02 + 0.04i) + 2 \sum_{i=1}^{49} f(1 + 0.04i) \right] \\ &\approx 17.367\ 255\ 11 \end{aligned}$$

But $\int_1^3 e^x dx = 17.367\ 255\ 09$

Hence, error = $8.89 \times 10^{-8} \%$

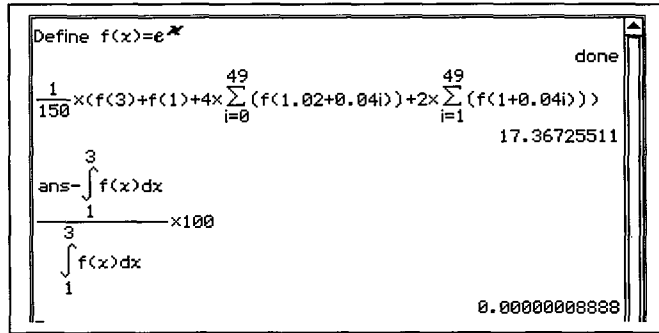

Exercise 15.1 *A CAS Calculator is essential for this exercise.*

- The accompanying diagram shows the graph of $y = f(x)$. A table of values accompanies this graph. Use 4 strips with each of the following methods to estimate the area of the shaded region.
 - Mid-point method.
 - Trapezium Rule.
 - Simpson’s Rule.

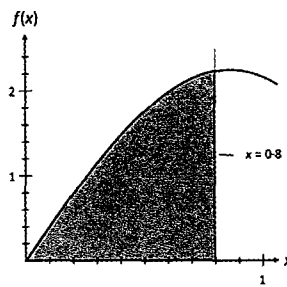

x	$f(x)$
0	0
0.1	0.4
0.2	0.78
0.3	1.15
0.4	1.47
0.5	1.76
0.6	1.98
0.7	2.14
0.8	2.23

Hence, compare the relative accuracies of each of these methods if the area of this region correct to four decimal places is 1.0824 .

- Use the mid-point method with the stated number of strips to estimate the value of each of the following integrals. Hence, calculate the percentage error for the method.

(a) $\int_1^4 x(4-x) dx$; 50 strips

(b) $\int_{-2}^3 x^2 - 16 dx$; 100 strips.

- Use the mid-point method with n strips to estimate each of the following integrals.

(a) $\int_0^1 e^{-x^2} dx, n = 20$

(b) $\int_0^1 \sin(x^2) dx; n = 50$

- Use the trapezium rule with 100 strips to estimate each of the following integrals.

(a) $\int_1^5 \ln(x^2 + 1) dx$

(b) $\int_{-1}^1 \sin(e^{-x}) dx$

- Use Simpson’s Rule with 100 strips to estimate each of the following integrals.

(a) $\int_0^4 e^{\sin(x)} dx$

(b) $y = \int_{-0.5}^1 \sqrt{\cos x} dx$

16 First Order Differential Equations

16.1 First Order Differential Equations of the form $\frac{dy}{dx} = f(x)$

- Consider the differential equation $\frac{dy}{dx} = f(x)$.
 - This is a first order differential equation. (The order of a differential equation is determined by the highest derivative in the equation.)
 - As anti-differentiation is the reverse of differentiation, the solution to the differential equation is $y = \int f(x) dx + C$.
 - This is known as the *general solution* to the differential equation. It consists of a family of *integral curves* of the form $y = \int f(x) dx + C$.
 - If additional information (called initial/boundary conditions) consisting of a set of point(s) is known, then the constant C can be determined. The solution obtained is called a *particular solution* to the differential equation.

Example 16.1

Find the general solution to the differential equation $\frac{dy}{dx} = \frac{2}{x^2 - 1}$.

Hence, find the particular solution corresponding to the initial condition of $x = 0, y = 2$

Solution:

$$\frac{dy}{dx} = \frac{2}{x^2 - 1} \Rightarrow y = \int \frac{2}{x^2 - 1} dx$$

Decompose integrand into its partial fractions:

$$\frac{2}{x^2 - 1} \equiv \frac{2}{(x-1)(x+1)} \equiv \frac{A}{x-1} + \frac{B}{x+1}$$

$$2 \equiv A(x+1) + B(x-1)$$

Substitute $x = -1$: $B = -1$

Substitute $x = 1$: $A = 1$

Hence, $y = \int \frac{1}{x-1} - \frac{1}{x+1} dx$

General Solution: $y = \ln|x-1| - \ln|x+1| + C$

Initial Conditions:

$x = 0, y = 2 \Rightarrow y = \ln|x-1| - \ln|x+1| + 2$

Particular Solution: $y = \ln\left|\frac{x-1}{x+1}\right| + 2$

```

dSolve{y' = 2/(x^2-1), x, y, x=0, y=2}
{y = -ln(|x+1|) + ln(|x-1|) + 2}
simplify(
    {y = ln(|(x-1)/(x+1)|) + 2}
    )
        
```

Exercise 16.1 *To be completed without the use of a calculator.*

1. Find the particular solution to each of the following differential equations:

(a) $\frac{dy}{dx} = \frac{2x}{x^2 + 1}, (0, -4)$

(b) $\frac{dy}{dx} = \frac{1-2x}{x^2 - 1}, (0, 2)$

(c) $\frac{dy}{dx} = \frac{x-3}{x^2 + 3x + 2}, (0, \ln 2)$

(d) $\frac{dy}{dx} = \frac{-1}{\sqrt{1-x^2}}, (-1, \frac{\pi}{2})$

(e) $\frac{dy}{dx} = \frac{2}{4x^2 + 1}, (\frac{1}{2}, \frac{\pi}{4})$

(f) $\frac{dy}{dx} = 2\sqrt{1-x^2}, (1, \frac{\pi}{2})$

2. The curve $y = f(x)$, has gradient function given by $\frac{dy}{dx} = a \sin^2 \pi x$, where a is a real constant. Find the equation of the curve given that it passes through the origin and $(1, -2\pi)$.
3. The curve $y = f(x)$, has gradient function given by $f'(x) = a \sin x \cos x$, where a is a real constant. Find the equation of the curve given that it passes through the points $(0, -2)$ and $(\frac{\pi}{2}, -1)$.
4. The tangent to the curve $y = f(x)$ at the point $(\frac{\pi}{2}, 4)$ is parallel to the line $y = 12x + 1$.
The gradient function of the curve is given by $\frac{dy}{dx} = a \sin^3 x$, where a is a real constant.
Find the equation of the curve given that it also passes through the point $(0, -4)$.
5. The gradient function of the curve is given by $\frac{dy}{dx} = 15x\sqrt{x+a}$, where a is a real constant. Find the equation of the curve given that it has a stationary point at $(-1, 2)$.
6. The tangent to the curve $y = f(x)$ at the point $(0, 2)$ is parallel to the line $y = 2x + 3$.
The gradient function of the curve is given by $\frac{dy}{dx} = \frac{-4x+a}{2x+1}$, where a is a real constant.
Find the equation of the curve.

16.2 First Order Differential Equations of the form $\frac{dy}{dt} = g(y)$

16.2.1 First Order Differential Equations of the form $\frac{dy}{dt} = ay + b$

- Let $y = f(t)$. If the rate of change of y with respect to time t is proportional to y , then the relationship can be expressed symbolically as:

$$\frac{dy}{dt} \propto y \quad \text{I}$$

$$\Rightarrow \frac{dy}{dt} = ky \quad \text{II}$$

- Statements I and II express an *exponential growth and decay* relationship between the two variables. This was discussed in Units 3 & 4 of the Mathematics Methods course. It was also mentioned that if:

$$\frac{dy}{dt} = ky \Rightarrow y = y_0 e^{kt}.$$

- In the section that follows, a mathematical technique referred to as the method of *separation of variables* will be used to prove the above result.

16.2.2 Separation of Variables Method for solving $\frac{dy}{dt} = ay + b$

- In this method, we will consider dy and dt as differentials.

- Separate the variables/differentials in $\frac{dy}{dt} = ky$

so that the “y’s” are all on the same side of the equation:

$$\frac{dy}{y} = k dt$$

- Integrate the equation: $\int \frac{1}{y} dy = \int k dt$

$$\ln|y| = kt + C$$

- Rewrite in exponential form: $y = e^{kt+C}$ (As $e^{kt+C} > 0 \forall t$)

Separate the exponents: $y = e^C e^{kt}$

When $t = 0$: $y = e^C$

Hence, e^C is the initial value for y ; denote this as y_0 .

- Hence, the solution to the differential equation $\frac{dy}{dt} = ky$ is $y = y_0 e^{kt}$,

where y_0 is the initial value for y .

- Rewriting the differential equation, $\frac{\left(\frac{dy}{dt}\right)}{y} = k$.

Hence, k represents the percentage growth rate for y .

- If $k > 0$, then the solution is an exponential growth function.
- If $k < 0$, then the solution is an exponential decay function.

Example 16.2

Without the use of a calculator, use the separation of variables method to solve the differential equation $\frac{dy}{dt} = -0.05y$ given that when $t = 0$ minutes, $y = 10\,000$.

Solution:

$$\frac{dy}{dt} = -0.05y$$

Separate the variables: $\frac{dy}{y} = -0.05 dt$

Integrate: $\int \frac{1}{y} dy = -0.05 \int 1 dt$

$$\ln(y) = -0.05t + C$$

$$y = e^{-0.05t+C}$$

When $t = 0, y = 10\,000 \Rightarrow e^C = 10\,000$

Hence $y = 10\,000 e^{-0.05t}$



```
dSolve(y'=-0.05*y,t,y,t=0,y=10000)
{y=10000*e^(-t/20)}
```

Example 16.3

Use the separation of variables method to find the general solution to $\frac{dy}{dt} = 2y - 1$.

Solution:

$$\frac{dy}{dt} = 2y - 1 \Rightarrow \frac{dy}{2y-1} = dt$$

Hence: $\frac{1}{2} \ln(2y-1) = t + C$ [Ignore $2y - 1 < 0$.]

$$2y - 1 = e^{2t+K}$$

Therefore, $y = \frac{1}{2} [1 + A e^{2t}]$ where $A = e^K$ is a constant.

Example 16.4

The initial temperature of a body is 100°C and the surrounding temperature is a constant 20°C . The body cools to 60°C in 25 minutes. The rate of cooling is proportional to the difference in temperature between the body and the surrounding medium.

- (a) Use a calculus method to show that the temperature after t minutes, θ , is given by $\theta = 20 + 80e^{(0.04\ln 2)t}$. Hence, find the temperature of the body after 100 minutes.
 (b) Determine the time it takes for the temperature of the body to reach 20°C .

Solution:

- (a) Rate of cooling $\propto (\theta - 20)$.

Hence:
$$\frac{d\theta}{dt} = -k(\theta - 20).$$

Separate the variables:
$$\frac{d\theta}{\theta - 20} = -k dt$$

Integrate:
$$\int \frac{1}{\theta - 20} d\theta = -k \int 1 dt$$

$$\ln(\theta - 20) = -kt + C$$

$$\theta - 20 = e^{-kt+C}$$

When $t = 0, \theta = 100: \Rightarrow e^C = 80$

Therefore:
$$\theta = 20 + 80e^{-kt}$$

When $t = 25, \theta = 60: 40 = 80e^{-25k}$

$$k = 0.04 \ln 2$$

Therefore,
$$\theta = 20 + 80e^{-(0.04\ln 2)t}$$

When $t = 100: \theta = 20 + 80e^{-4\ln 2}$

$$= 25^{\circ}\text{C}.$$

- (b) From the equation $\theta = 20 + 80e^{-(0.04\ln 2)t}$, $\theta = 20$ is an asymptote.

Hence, in theory the body will never reach 20°C .

However, in practice if we assume that $20.01 \approx 20$:

$$20 + 80e^{-(0.04\ln 2)t} = 20.01$$

$$t \approx 324 \text{ minutes.}$$

That is, it will take about 324 minutes.

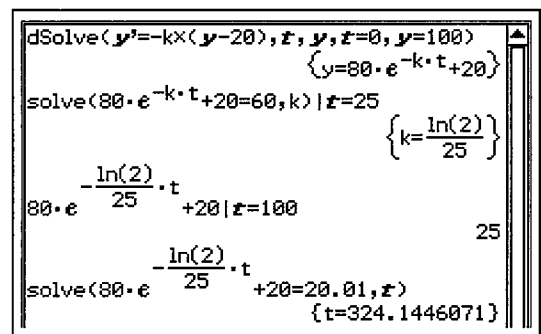

Example 16.5

A container contains 10 litres of a salt solution with a concentration of 5 g of salt per litre. Another solution with a concentration of 10 g of the same salt per litre flows into the container at a rate of 2 litres per minute. The concentration of the salt solution in the container is kept uniform by constant stirring. The mixture flows out of the container at a rate of 2 litres per minute.

(a) Show that, Q , the amount of salt after t minutes, is given by $Q = 100 - 50e^{-0.2t}$.

(b) Show that the concentration of the salt in the mixture cannot exceed 10 g per litre.

Solution:

(a) $\frac{dQ}{dt}$ = Rate of salt “flowing in” – Rate of salt “flowing out”.

At any time t , there will be 10 litres of the mixture in the container. Since at time t , the amount of salt present is Q , the concentration of the mixture at time t , is $\frac{Q}{10}$ g/L.

The mixture is flowing out of the container at a rate of 2 L/min. Hence, the rate with which the salt is “flowing out” of the container is $\frac{Q}{10} \times 2 = \frac{Q}{5}$ g/min.

The rate with which salt is flowing in is $2 \times 10 = 20$ g/min.

$$\begin{aligned} \text{Therefore,} \quad \frac{dQ}{dt} &= 20 - \frac{Q}{5} \\ &= \frac{100 - Q}{5} \end{aligned}$$

$$\text{Separate the variables,} \quad \frac{dQ}{100 - Q} = \frac{1}{5} dt$$

$$\begin{aligned} \text{Integrate} \quad \int \frac{dQ}{100 - Q} &= \frac{1}{5} \int 1 dt \\ -\ln(100 - Q) &= 0.2t + K \\ 100 - Q &= e^{-0.2t + C} \end{aligned}$$

$$\text{When } t = 0, Q = 50, \quad \Rightarrow e^C = 50$$

$$\text{Hence,} \quad Q = 100 - 50e^{-0.2t}$$

(b) As $t \rightarrow \infty, e^{-0.2t} \rightarrow 0$.

Hence, as $t \rightarrow \infty, Q \rightarrow 100$ (from the lower end).

That is, as $t \rightarrow \infty$, the concentration $\rightarrow 100/10 = 10$ g/L.

Hence, the concentration of the mixture cannot exceed 10 g/L.

Exercise 16.2

1. Use the separation of variables method to find the particular solution to:

(a) $\frac{dy}{dt} = 0.02y$; when $t = 0$, $y = 100$	(b) $\frac{dy}{dt} - 3y = 0$; when $t = 0$, $y = 50$
(c) $\frac{dy}{dt} = 2 + y$; when $t = 0$, $y = 200$	(d) $\frac{dy}{dt} = 4 - 3y$; when $t = 0$, $y = 400$
(e) $\frac{dy}{dt} = -2(1 + 5y)$; $y(0) = 100$	(f) $\frac{dy}{dt} = 10(1 - 2y)$; $y(0) = 200$

2. A variable y experiences exponential growth with a percentage growth rate of 3% per hour. Given $y(0) = 100\ 000$, describe the growth in y in terms of a differential equation.

3. A bacterial colony grows in such a way that its growth rate at time t (minutes) is equal to one third its population at time t (minutes). Describe the population growth in terms of a differential equation given that the initial population is 100 000.

4. The radioactive substance beryllium decays according to the differential equation $\frac{dy}{dt} = -1.5 \times 10^{-7} y$ where time t is measured in years. Determine its half-life.

5. 30% of a radioactive substance disappears after 100 years. Determine the half-life of the substance given that the decay is exponential. Determine the number of years that has to lapse before there is only 5% of the original substance left.

6. If a radiation dosage of 0.2 rad is sufficient to kill 50% of a population of cancer cells, determine the dosage required to kill 99% of the cancer cells present. Assume that the rate with which the cancer cells are killed by the radiation is proportional to the number cells present.

7. In a medical procedure, a tracer dye is injected into the pancreas to measure its function rate. In a pancreas that is functioning normally, 4% of the dye will be excreted each minute. A dosage of 0.5g of the dye is administered to a patient. Determine the total amount of dye that will be secreted after 1 hour if the pancreas was functioning normally.

8. At the start of 1975 it was estimated that the world's population was 4 billion. Determine the percentage growth/decay rate for the world's population to exponentially:

(a) increase to 5 billion in 10 years	(b) decline (!) to 3 billion in 100 years.
---------------------------------------	--

9. The original temperature of a body is 90°C and the surrounding temperature is a constant 20°C . The body cools to 70°C in 5 minutes. Assume that the rate of cooling is proportional to the difference between the temperature of the body and that of the surrounding medium.

(a) Show that the temperature, θ , after t minutes is of the form $\theta = 20 + 70e^{-kt}$.	(b) Find the time taken for the temperature of the body to drop to 35°C .
--	---

10. The original temperature of a body is 800°C and the surrounding temperature is a constant 35°C . The body cools to 600°C in 10 minutes. Assume that the rate of cooling is proportional to the difference between the temperature of the body and that of the surrounding medium.
- (a) Use a calculus method to show that the temperature, θ , after t minutes is given by $\theta = 35 + 765 e^{-kt}$, giving the value of k .
- (b) Find the time taken for the temperature of the body to drop to 100°C .
11. The relationship between the resistance current I and time t in an electric circuit is given by $\frac{dI}{dt} = 8 - 4I$. Given that $I = 0$ amps when $t = 0$ seconds, find I in term of t .
12. A tank contains 100 litres of a salt solution which has 40 g of dissolved salt. Water flows into the tank at a rate of 2 L/min. The concentration of the salt solution in the tank is kept uniform by constant stirring. The mixture is siphoned out of the tank at a rate of 2 L/min. The amount of salt at time t minutes is Q g.
- (a) Show that $\frac{dQ}{dt} = -\frac{Q}{50}$. Hence, use a calculus method to show that $Q = 40 e^{-\frac{t}{50}}$.
- (b) Find the time taken for the concentration to drop to 0.1 g/L.
13. A tank contains 100 litres of brine with a concentration of 5 g/L. Fresh brine with a concentration of 20 g/L flows into the tank at a rate of 4 litres per minute. The concentration of the solution in the tank is kept uniform by constant stirring. The mixture flows out of the container at a rate of 4 litres per minute. The amount of salt at time t minutes is Q g.
- (a) Show that $\frac{dQ}{dt} = a - \frac{Q}{b}$, giving the values of the constants a and b .
- (b) Hence, show that $Q = m - n e^{-kt}$, giving the values of the constants m , n and k .
- (c) Find when the concentration of the mixture in the tank reaches 6 g/L.
- (d) Find u and v , such that for any time t , $u \leq Q < v$.
14. A tank contains 500 litres of brine with a concentration of 20 g/L. Fresh brine with a concentration of 2 g/L flows into the tank at a rate of 8 litres per minute. The concentration of the solution in the tank is kept uniform by constant stirring. The mixture flows out of the container at a rate of 8 litres per minute. The amount of salt at time t minutes is Q g.
- (a) Show that $\frac{dQ}{dt} = a - \frac{Q}{b}$, giving the values of the constants a and b .
- (b) Hence, show that $Q = m + n e^{-kt}$, giving the values of the constants m , n and k .
- (c) Find when the concentration of the mixture in the tank reaches 5 g/L.
- (d) Find u and v , such that for any time t , $u < Q \leq v$.

16.2.3 Separation of Variables Method for solving logistic equations: $\frac{dy}{dt} = ay(b - y)$

- The exponential growth model $\frac{dy}{dt} = ky$ with solution $y = y_0 e^{kt}$ allows the variable y to grow indefinitely (as $t \rightarrow \infty, y \rightarrow \infty$).
- In many disciplines, for example in biology/ecology, the exponential growth model is effective in describing the growth of the variable (population) in the early stages. However, because of constraints of space, food and other factors, the growth declines in the later stages and reaches a limit. Hence, we require a model that supports exponential growth in the early stages but with a slowing of growth in the later stages.
- A model that meets these requirements is the *logistic growth model* which is represented by the differential equation $\frac{dy}{dt} = ky\left(1 - \frac{y}{b}\right) \equiv \frac{k}{b}y(b - y)$

with solution $y = \frac{b}{1 + Ae^{-kt}}$ where b, k and A are constants.

The solution to a *logistic differential equation* is called a *logistic function*.

- The diagrams below compare the graph of an exponential growth model with that of a logistic growth model.

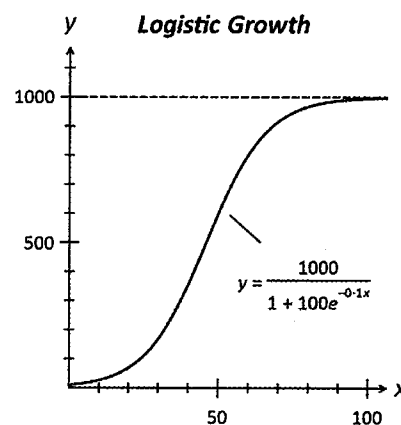
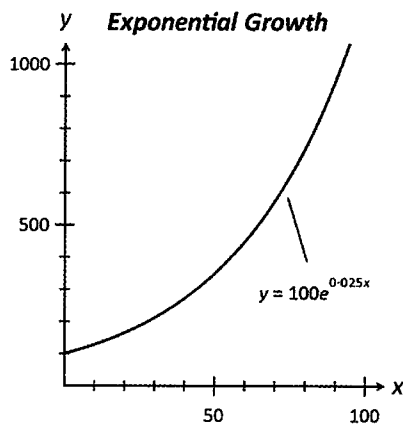

- Observe that the logistic curve has a horizontal asymptote which caps its growth. This asymptote marks the limiting value for y . In population modelling, this limit is called the *carrying capacity*. The exponential curve, on the other hand conveys indefinite growth.
- For $\frac{dy}{dt} = ky\left(1 - \frac{y}{b}\right) \equiv \frac{k}{b}y(b - y)$ with solution $y = \frac{b}{1 + Ae^{-kt}}$:
 - the initial value for $y, y(0) = \frac{b}{1 + A}$
 - the constant k is the growth constant
 - the constant b is the limiting value for y .

Example 16.6

Find the general solution to the differential equation $\frac{dy}{dt} = ky\left(1 - \frac{y}{b}\right) \equiv \frac{k}{b}y(b-y)$

where b and k are constants. Hence, determine the limiting value of y in terms of b and/or k .

Solution:

Separate the variables:
$$\frac{1}{y(b-y)} dy = \frac{k}{b} dt$$

Integrate:
$$\int \frac{1}{y(b-y)} dy = \frac{k}{b} dt$$

Decompose integrand into its partial fractions:

$$\frac{1}{y(b-y)} \equiv \frac{R}{y} + \frac{S}{b-y}$$

$$1 \equiv R(b-y) + Sy$$

Substitute $y = 0$:
$$R = \frac{1}{b}$$

Substitute $y = b$:
$$S = \frac{1}{b}$$

Hence:
$$\frac{1}{b} \int \frac{1}{y} + \frac{1}{b-y} dy = \int \frac{k}{b} dt$$

$$\int \frac{1}{y} + \frac{1}{b-y} dy = b \int \frac{k}{b} dt$$

$$\ln\left(\frac{y}{b-y}\right) = kt + C$$

$$\frac{y}{b-y} = M e^{kt}$$

$$y = M e^{kt} (b-y)$$

$$y(1 + M e^{kt}) = M b e^{kt}$$

$$y = \frac{M b e^{kt}}{1 + M e^{kt}}$$

Divide each term with $M e^{kt}$:
$$y = \frac{b}{\frac{1}{M e^{kt}} + 1}$$

Hence:
$$y = \frac{b}{A e^{-kt} + 1}$$

As $t \rightarrow \infty$, $A e^{-kt} \rightarrow 0$ and $y \rightarrow b$.

Hence, limiting value for y is b .

Example 16.7

The population P of a colony of marsupials on a remote island at time t years is modelled by the differential equation $\frac{dP}{dt} = 0.0001P(5\,000 - P)$. At $t = 0$, the size of the colony was 500.

- (a) Use the variables separable method to show that $P = \frac{A}{1 + Be^{-kt}}$ for constants A , B and k .
 (b) Determine the maximum size of this colony. Discuss when the colony reaches this size.

Solution:

(a) Separate the variables:
$$\frac{1}{P(5000 - P)} dP = 0.0001 dt$$

Integrate:
$$\int \frac{1}{P(5000 - P)} dP = \int 0.0001 dt$$

Decompose integrand into its partial fractions:

$$\frac{1}{P(5000 - P)} = \frac{R}{P} + \frac{S}{5000 - P}$$

Hence:
$$1 \equiv R(5000 - P) + SP$$

Substitute $P = 0$:
$$R = \frac{1}{5000}$$

Substitute $P = 5000$:
$$S = -\frac{1}{5000}$$

Hence:
$$\frac{1}{5000} \int \left(\frac{1}{P} - \frac{1}{5000 - P} \right) dP = \int 0.0001 dt$$

$$\ln \left(\frac{P}{5000 - P} \right) = 0.5t + C$$

$$\frac{P}{5000 - P} = M e^{0.5t}$$

$$P = M e^{0.5t} (5000 - P)$$

$$P(1 + M e^{0.5t}) = 5000 M e^{0.5t}$$

$$P = \frac{5000 M e^{0.5t}}{1 + M e^{0.5t}}$$

Divide each term with $M e^{0.5t}$:

$$P = \frac{5000}{\frac{1}{M e^{0.5t}} + 1}$$

Hence:
$$P = \frac{5000}{A e^{-0.5t} + 1}$$

But $P(0) = 500$:
$$500 = \frac{5000}{A + 1} \Rightarrow A = 9$$

Therefore:
$$P = \frac{5000}{1 + 9e^{-0.5t}}$$

- (b) Limiting value for P is 5000. $P(20) \approx 4998$.
 Hence, maximum size is reached after about 20 years.

Example 16.8

In a chemical reaction, the concentration C of a chemical in a solution is modelled by the equation $\frac{dC}{dt} = 0.2C\left(1 - \frac{C}{100}\right)$ where t is time in minutes. The initial concentration of the chemical is 0.01 g/L.

- (a) Use the variables separable method to show that $C = \frac{A}{1 + Be^{-kt}}$ for constants A , B and k .
 (b) Hence, determine the time it takes for the concentration to reach half its limiting value.

Solution:

(a) Rewrite the equation: $\frac{dC}{dt} = 0.002C(100 - C)$

Separate & integrate: $\int \frac{1}{C(100 - C)} dC = \int 0.002 dt$

Express integrand as partial fractions:

$$\frac{1}{C(100 - C)} = \frac{p}{100 - C} + \frac{q}{C}$$

Hence:

$$1 \equiv pC + q(100 - C)$$

$$\Rightarrow p = \frac{1}{100} \quad \text{and} \quad q = \frac{1}{100}$$

Therefore:

$$\frac{1}{100} \int \frac{1}{100 - C} + \frac{1}{C} dC = \int 0.002 dt$$

$$- \ln \left(\frac{100 - C}{C} \right) = 0.2t + K$$

$$\frac{100 - C}{C} = A e^{-0.2t}$$

$$100 - C = CA e^{-0.2t}$$

$$C(1 + A e^{-0.2t}) = 100$$

$$C = \frac{100}{1 + A e^{-0.2t}}$$

Since $C(0) = 0.01$:

$$A = 9999.$$

Hence:

$$C = \frac{100}{1 + 9999 e^{-0.2t}}$$

- (b) Limiting value for $C = 100$ g/L.

For $C = 50$ g/L: $50 = \frac{100}{1 + 9999 e^{-0.2t}}$

$$t \approx 46.1 \text{ minutes.}$$

Exercise 16.3

1. Construct a logistic differential equation $\frac{dP}{dt}$ for each of the following scenarios:

	Growth Rate	Limiting Value
(a)	0.2	1000
(b)	0.1	500
(c)	0.5	10 000
(d)	0.25	5 000

2. For each of the following logistic differential equation, state the growth rate and the limiting value for the variable. Hence, state the solution to the differential equation in the form of a logistic function.

(a) $\frac{dP}{dt} = 0.002P(1\,000 - P)$, $P(0) = 50$ (b) $\frac{dQ}{dt} = 0.0005Q(100 - Q)$, $Q(0) = 20$
 (c) $\frac{dC}{dt} = 0.1C\left(1 - \frac{C}{50}\right)$, $C(0) = 5$ (d) $\frac{d\theta}{dt} = 0.05\theta\left(1 - \frac{\theta}{1000}\right)$, $\theta(0) = 40$

3. Use the separation of variables method to solve the following differential equations.

(a) $\frac{dy}{dt} = 0.02y(200 - y)$; $y(0) = 100$ (b) $\frac{dP}{dt} = P - 0.01P^2$; $P(0) = 10$
 (c) $\frac{dP}{dt} = 0.2P\left(1 - \frac{P}{50}\right)$; $y(0) = 40$ (d) $\frac{dx}{dt} = -0.5x(0.01x - 1)$; $x(0) = 20$

4. The population P of a colony of marsupials at a remote island at time t years is modelled by the differential equation $\frac{dP}{dt} = 0.0005P(100 - P)$. At $t = 0$, $P = 25$.

(a) Use the variables separable method to show that $P = \frac{A}{1 + Be^{-kt}}$,
 stating the values of A , B and k .

- (b) Determine the time it takes for the population to reach half its limiting value.

5. The population P of a colony of rabbits at time t months is modelled by the differential equation $\frac{dP}{dt} = 0.08P\left(1 - \frac{P}{20\,000}\right)$. At $t = 0$, $P = 200$.

(a) Use the variables separable method to show that $P = \frac{A}{1 + Be^{-kt}}$,
 stating the values of A , B and k .

- (b) Determine the time it takes for the population to effectively reach its limiting value.

6. The number of people infected by a strain of influenza is modelled by

$\frac{dP}{dt} = 10P - 0.005P^2$ where t is time in months after the detection of the virus strain

- among 10 influenza patients. Use the variables separable method to determine the time it takes for the infection to reach 80% of its limiting value.

7. In a chemical reaction, the concentration C of a chemical in a solution is modelled by the equation $\frac{dC}{dt} = 0.02C\left(1 - \frac{C}{50}\right)$ where t is time in minutes. The initial concentration of the chemical is 8 g/L. Determine the time it takes for the concentration to effectively reach its limiting value.
8. A certain school has a student population of 1 200 students. The spread of a rumour among the student population started by a single student may be modelled by $\frac{dP}{dn} = 960P - 0.8P^2$ where $P(n)$ represents the number of students who have already heard the rumour by the day n . Determine the time it takes for the rumour to spread to 90% of the student population.
9. The number of particles trapped by an air-filtering system is modelled by the equation $\frac{dN}{dt} = -0.75N^2 + 75\,000N$ where $N(t)$ represents the number of particles trapped after t hours. The air-filtering system requires a filter-change when it reaches 90% of its filtering capacity. Initially, there were 10 particles trapped. Assuming that the rate of filtering remains unchanged, determine how often the filters need to be changed.
10. A fast food company intends to capture the custom of 70% of a suburb of 10 000 families within the first week of its opening. The number of families who have frequented the store t days after its opening $N(t)$ is modelled by $N'(t) = -0.6N^2 + 6000N$. Determine if the company can achieve this goal.
11. Consider the logistic differential equation $\frac{dP}{dt} = kP\left(1 - \frac{P}{1000}\right)$ with $P(0) = 100$. Find the value of k if P is to achieve half its limiting value when $t = 20$.
12. The concentration of a salt in a solution is modelled by $\frac{dC}{dt} = kC\left(1 - \frac{C}{100}\right)$ where $C(t)$ is the concentration of the salt at time t minutes. Given that $C(0) = 10$ g/L, find k if the salt concentration is to reach 75% of its maximum concentration after 50 minutes.
13. Use differentiation to find $\frac{dP}{dt}$ in the form $kP\left(1 - \frac{P}{A}\right)$ where k and A are constants if
$$P = \frac{1000}{1 + 99e^{-0.1t}}.$$
- *14. Use the variables separable method to find the general solution to
$$\frac{dy}{dt} = 2(y+1)(y+2), \quad y(0) = 1.$$

16.3 First Order Differential Equations of the form $\frac{dy}{dx} = f(x)g(y)$

- The separation of variables method is used to solve differential equations of this form.

Example 16.9

Use the method of separation of variables to solve the differential equation $\frac{dy}{dx} = \frac{1+2y}{1+x}$, given that $y(0) = 10$.

Solution:

Separate the variables: $\left(\frac{1}{1+2y}\right)dy = \left(\frac{1}{1+x}\right)dx$

Integrate: $\int\left(\frac{1}{1+2y}\right)dy = \int\left(\frac{1}{1+x}\right)dx$

$$\frac{1}{2}\ln(1+2y) = \ln(1+x) + \ln k \quad (\text{where } \ln k \text{ is a constant})$$

$$\ln(1+2y)^{\frac{1}{2}} = \ln[k(1+x)]$$

Hence: $(1+2y)^{\frac{1}{2}} = k(1+x)$

$$y = \frac{1}{2}[k^2(1+x)^2 - 1]$$

Since $y(0) = 10$, $k^2 = 21$

Therefore: $y = \frac{1}{2}[21(1+x)^2 - 1]$

$$y = \frac{21x^2}{2} + 21x + 10$$

Exercise 16.4

1. Use the method of separation of variables to find the general solution to:

(a) $x\frac{dy}{dx} = 1+x^2$ (b) $(x-1)\frac{dy}{dx} = 1+y$ (c) $\frac{xy}{(1-x^2)}\frac{dy}{dx} = 1-y^2$ (d) $\frac{dy}{dx} + y\sin x = 0$

2. Use the method of separation of variables to find the particular solution to:

(a) $2y\frac{dy}{dx} = e^x, y(0) = 2$ (b) $(1+x^2)\frac{dy}{dx} = 2x, y(-1) = 0$

(c) $\frac{dy}{dx} = \frac{1}{(x+1)(y+1)}, y(0) = 1$ (d) $x\frac{dy}{dx} - (x+1)(y+1) = 0, y(1) = 2$

(e) $y(1+x^2)\frac{dy}{dx} = x(1+y^2), y(1) = 1$ (f) $y\sin^2 x \frac{dy}{dx} + \frac{1}{\tan x} = 0, y(\pi/2) = 0$

16.4 Slope/Direction Fields of First Order Differential Equations

- Slope fields or direction fields convey how the curves of general solutions to differential equations may look like without actually solving the differential equations.
 - In many cases, by applying special mathematical techniques on relevant portions of a slope field, particular solutions may be found.

- Consider the differential equation $\frac{dy}{dx} = x$.
 - The accompanying diagram shows the associated slope field.
 - The shape of the slope field is “parabolic” in form, consistent with the general solution $y = \frac{x^2}{2} + C$.
 - A particular solution with initial condition $x = 1, y = 1$ is also shown.

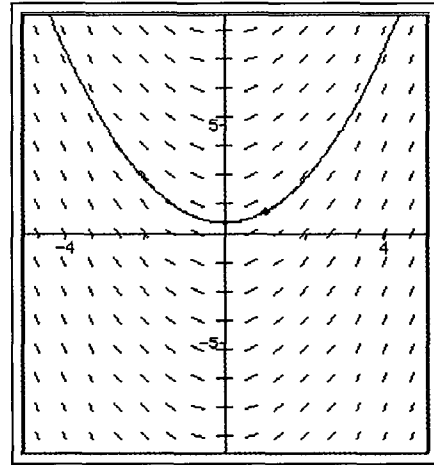

- Consider the differential equation $\frac{dy}{dx} = -x^2$.
 - The accompanying diagram shows the associated slope field.
 - The shape of the slope field is “cubic” in form, consistent with the general solution $y = -\frac{x^3}{3} + C$.
 - A particular solution with initial condition $x = 1, y = 1$ is also shown.

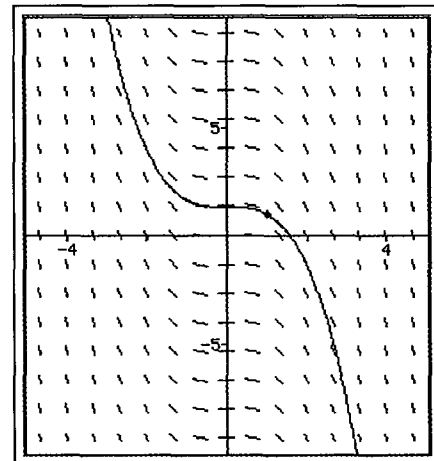

- Consider the differential equation $\frac{dy}{dx} = \frac{x}{y}$.
 - The accompanying diagram shows the associated slope field.
 - Three particular solutions are shown with initial conditions $(1, 2)$, $(1, -2)$ and $(4, 1)$ respectively.

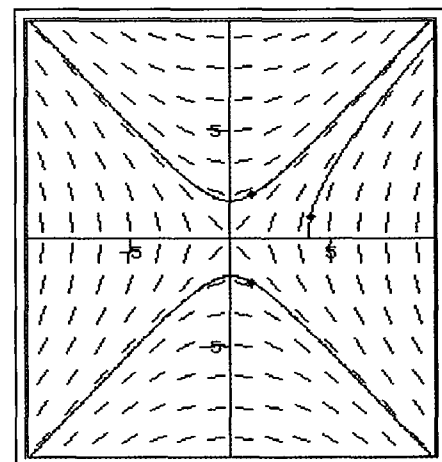

16.4.1 Drawing slope fields

- In this section, we will examine how slope fields are drawn.
- Consider the differential equation $\frac{dy}{dx} = \frac{x}{y}$.
 - The RHS of the differential equation indicates that the gradients of the curves representing the general solutions at any point (x, y) is $\frac{x}{y}$.
 - The table below shows the gradients at (x, y) for integer values of x and y for $-2 \leq x \leq 2, -2 \leq y \leq 2$.

$y \backslash x$	-2	-1	0	1	2
-2	1	0.5	0	-0.5	-1
-1	2	1	0	-1	-2
0	$\rightarrow \infty$	$\rightarrow \infty$	indeterminate	$\rightarrow \infty$	$\rightarrow \infty$
1	-2	-1	0	1	2
2	-1	-0.5	0	0.5	1

- Mark each of the points with a short line with the stated gradient.
 - For example, at the point $(-2, -2)$, mark this point with a short line (dash) with gradient 1.
- The gradients at $(-2, 0), (-1, 0), (1, 0)$ and $(2, 0)$ tend to infinity. Hence, mark these points with vertical dashes.
- The gradients at $(0, -2), (0, -1), (0, 1)$ and $(0, 2)$ are zero. Hence, mark these points with horizontal dashes.
- The gradient at the point $(0, 0)$ is indeterminate. Leave this point unmarked.
- The diagram below includes points midway between the points listed above.

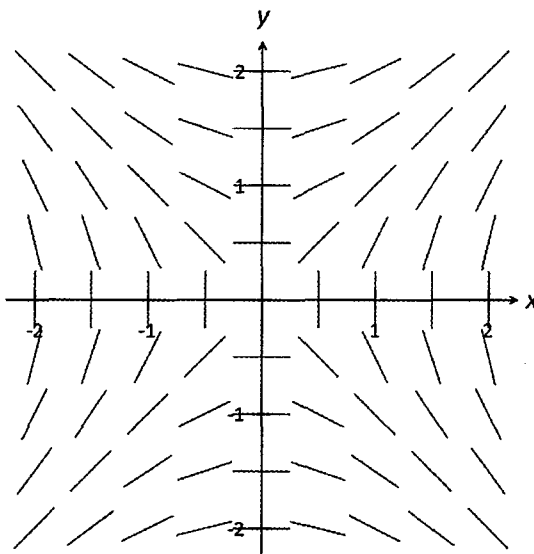

- Clearly, drawing a slope field by hand is an extremely tedious process. CAS calculators provide a convenient and efficient means of “drawing” slope fields. Using a slope field we can make intelligent guesses about the form of the solution to a differential equation without actually solving it.

Example 16.10

On your CAS calculator generate the slope field for $\frac{dy}{dx} = y$.

Generate the curve representing the particular solution with initial condition (2, 2).

Solution:

The process described below is for the Casio ClassPad.

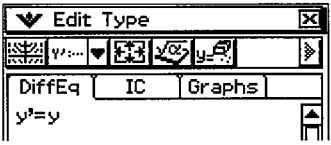
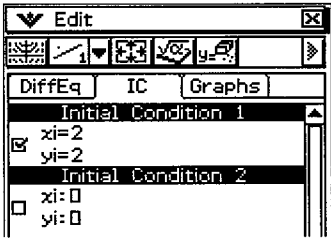
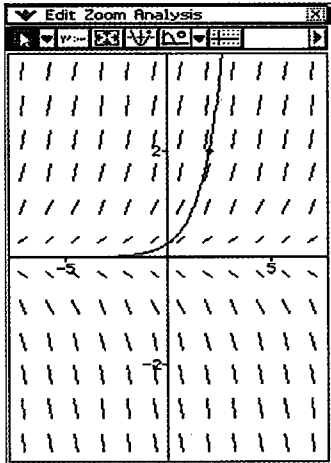
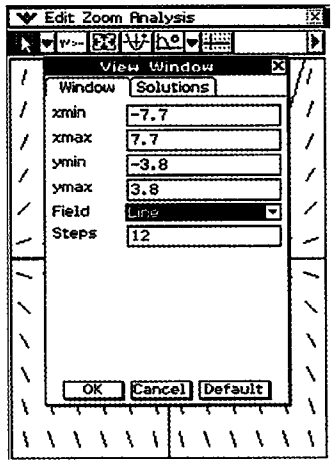
1	Activate the DiffEq Graph Wizard.	
2	Input the differential equation. <ul style="list-style-type: none"> In the DiffEq tab, enter y into the active box. 	
3	Input initial Condition. <ul style="list-style-type: none"> In the IC tab, under the "Initial Condition 1" box, enter $x = 2$ and $y = 2$. Check the box. 	
4	To display slope field. <ul style="list-style-type: none"> Tap the slope-field icon. To change the view of the slope field, use the "view-window" and the "zoom" icons. 	
5	The screen above was obtained as follows: <ul style="list-style-type: none"> Tap the "Resize" icon and the menu bar. Tap the "view-window icon". Tap the "Default" box. Select "Line" in the drop-down "Field" box. Leave "Steps" as 12. <p>The domain and range is divided into 12 intervals each, giving $12 \times 12 = 144$ "dashes".</p> Tap the "OK" box. Tap the "Zoom" icon and select "Square" from the drop-down menu. 	

Example 16.11

On the slope field given, draw in the curve representing the particular solution with initial condition:

- (a) $(1, 1)$ (b) $(-2, -1)$.

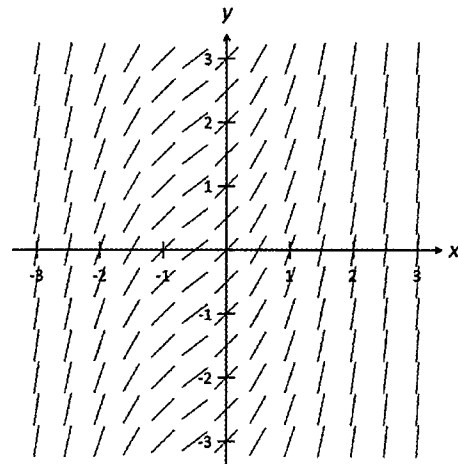

Solution:

- (a) To draw the required curve.
- Locate the point $(1, 1)$.
 - Note the direction of the “dash” at this point.
 - Following the “flow” of this dash, trace a curve that is “parallel” to the other dashes.
 - It is important to note that the required curve is *not* obtained by joining the dashes.

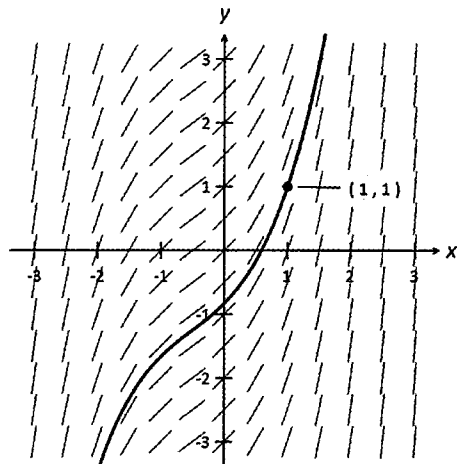

- (b) To draw the required curve.
- Locate the point $(-2, -1)$.
 - Note the direction of the “dash” at this point.
 - Following the “flow” of this dash, trace a curve that is “parallel” to the other dashes.
 - The curve may pass through other dashes but mostly it passes in between the dashes.

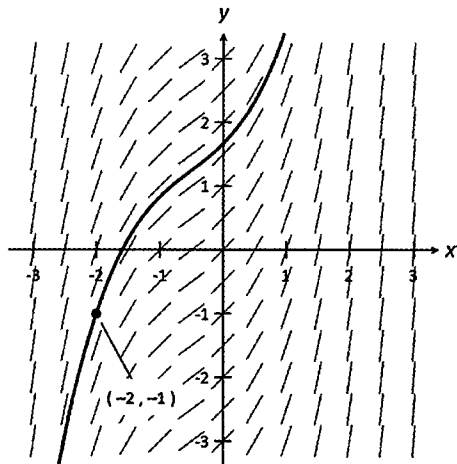

Example 16.12

On the slope field given, draw in the integral curve with initial condition:

- (a) $(2, 0)$ (b) $(-2, -2)$.

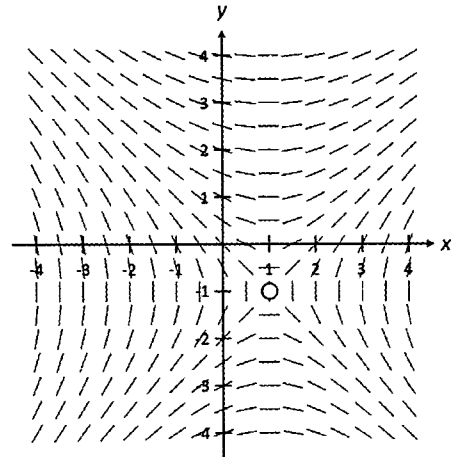

Solution:

- (a) • Note that the point $(0, 0)$ has indeterminate gradient.
 • The curve passing through $(2, 0)$ is actually a line.
 • This line does not pass through the “other side” of a point with indeterminate gradient.

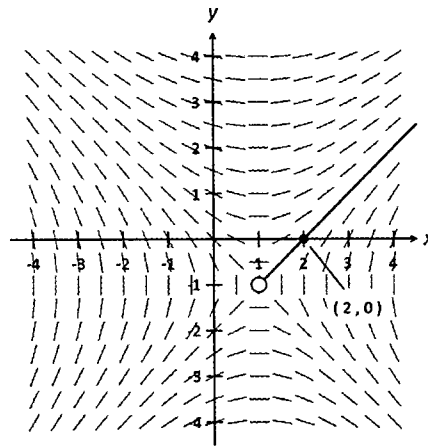

- (b) • The curve that passes through $(-2, -2)$ passes through a point with a vertical dash.
 • This point has infinite gradient.
 • The curve does not pass through the “other side” of a point with infinite gradient.

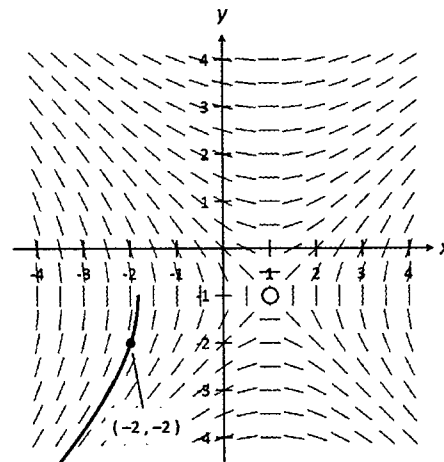

Note:

- Curves representing particular solutions do not pass through to the other side of points with either infinite or indeterminate gradients.

Example 16.13

For the given slope field, which of the following equations best describe the associated differential equation. Give reasons for your answer.

- A. $y' = y(y - 2)$ B. $y' = y$ C. $y' = y(y + 2)$.
 D. $y' = y(2 - y)$.

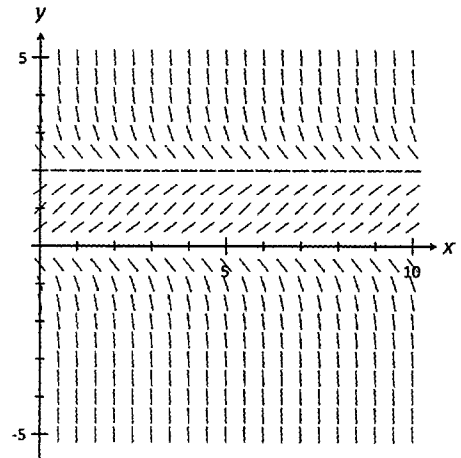

Solution:

From the slope field, gradient is 0 for $y = 0$ and $y = 2$. Hence, B and C can be ruled out.

The gradient is negative for $y > 2$, hence it can only be D.

Example 16.14

Suggest with reasons a general differential equation that corresponds to the given slope field.

(a)

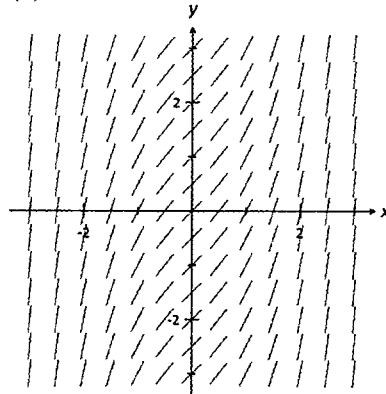

(b)

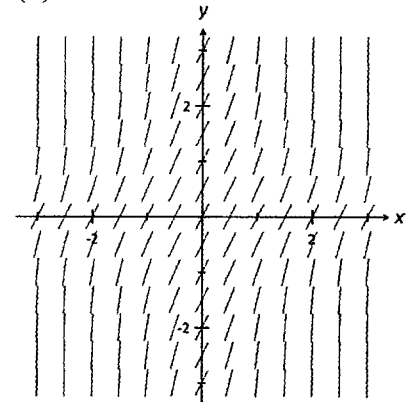

Solution:

- (a) The slopes are all positive.

Hence, y' consists of even powers of x and even powers of y add a positive constant. But the slopes for any particular value of x are the same and hence not dependent on the y -values. Therefore, we can rule out all the powers of y .

From the steepness of the dashes, it can be deduced that the highest even power could possibly be not more than 2.

Therefore, $y' = ax^2 + b$, where a and b are positive constants.

- (b) The slopes are all positive.

Hence, y' consists of even powers of x and even powers of y add a positive constant.

For any particular value of x , the slopes get steeper as the y -values increase.

Hence, y' depends on both x and y values.

The slopes along the x -axis are the same as those along the y -axis.

Hence, it cannot be $y' = ax^{2n} + by^{2m} + c$. It must be of the form $y' = kx^{2n} \times y^{2m} + c$.

From the steepness of the dashes, $y' = kx^2 y^2 + c$, where k and c are positive constants.

16.4.2 Isoclines

- Isoclines are curves that trace the points on a slope field that share the same gradient.
- The accompanying diagram is the slope field for the equation $y' = y(2 - y)$ as was seen in Example 16.13.

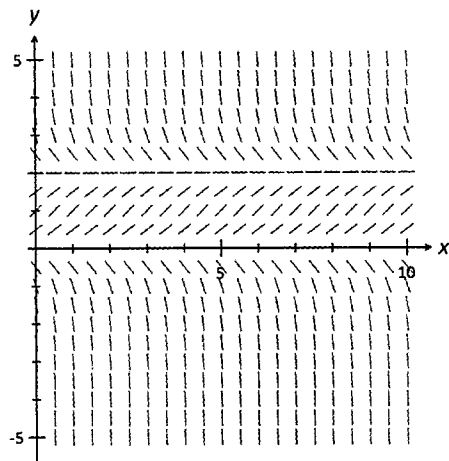

- All the dashes on the line $y = 4$ have the same gradient. Hence, $y = 4$ is an isocline.
- In fact, as long as the gradients are not infinite or indeterminate, $y = k$ for constant k are isoclines.
- Hence, the gradient of the curve does not depend on the x -values.
- This implies that there is no x term on the RHS of the differential equation.
- Hence, if the isoclines of finite gradients consist only of horizontal lines, then the RHS of the differential equation does not contain any x -terms.
- Similarly, if the isoclines of finite gradients consist only of vertical lines, then the RHS of the differential equation does not contain any y -terms (Example 16.14a).

Example 16.15

The accompanying diagram shows the slope field for $y' = \frac{x+1}{y}$. State the equation of the isocline of gradient 0.5 and sketch this isocline on the slope field.

Solution:

$$\text{Gradient is } 0.5 \Rightarrow \frac{x+1}{y} = 0.5$$

$$\text{Hence, } y = 2(x+1) \text{ where } x \neq -1 \cap y \neq 0.$$

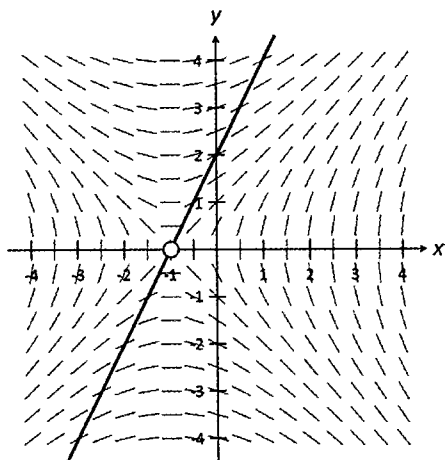
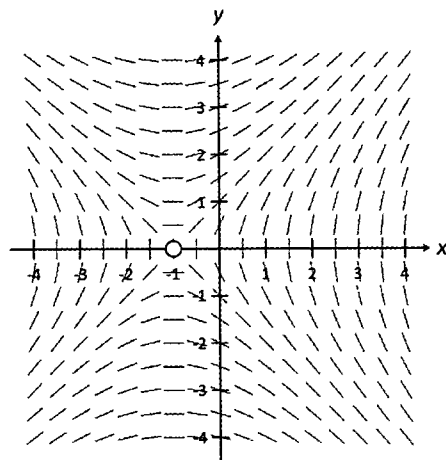

Exercise 16.5

1. On the slope field given, draw in the curve representing the particular solution with initial condition:

(a) $(1, 1)$ (b) $(-2, -1)$.

In each case state the coordinates of the minimum point and estimate the coordinates of the y -intercept.

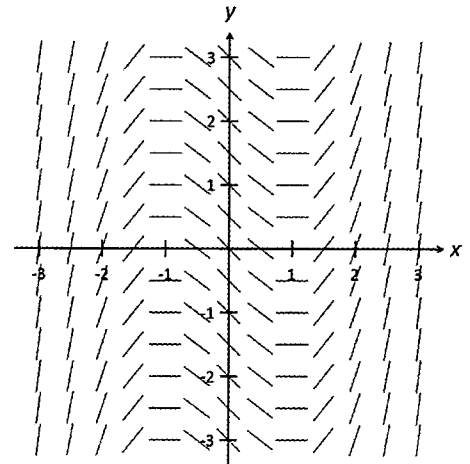

2. The accompanying diagram shows the slope field of a differential equation.

(a) On the slope field given, draw in the curve representing the particular solution with initial condition:

(i) $(15, 10)$ (b) $(20, -10)$.

In each case, estimate the value of $y(10)$.

(b) State the equation of the isocline with zero gradient.

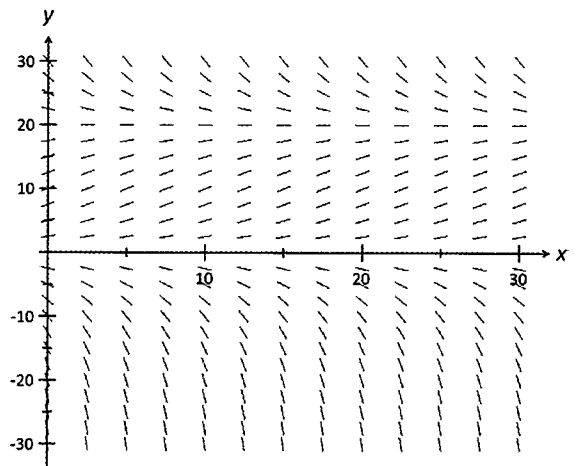

3. The accompanying diagram shows the slope field of a differential equation.

(a) On the slope field given, draw in the integral curve with initial condition:

(i) $(2, -1)$ (ii) $(-1, -1)$.

In each case, estimate the value of x when $y = 0$, where it exists.

(b) State the equation of the isocline with gradient one.

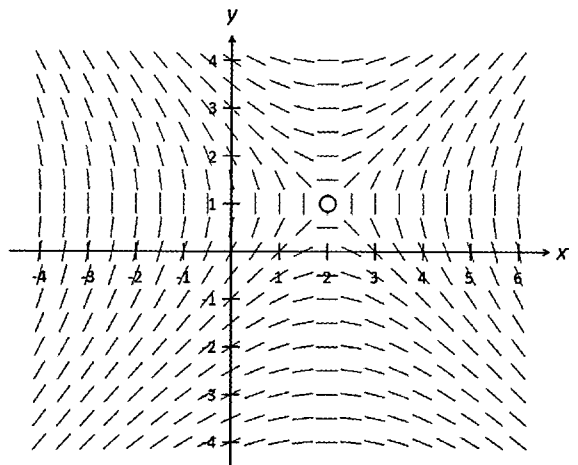

4. For the slope field given in Question 3, which of the following equations best describe the associated differential equation. Give reasons for your answer.

A. $y' = \frac{x+2}{y-1}$ B. $y' = \frac{y-2}{x-1}$ C. $y' = \frac{2-x}{1-y}$ D. $y' = \frac{x-2}{y+1}$.

For the equation you have chosen, state the equation of the isocline with gradient -2 .

5. The accompanying diagram shows the slope field of a differential equation.

- (a) Sketch the integral curve with initial condition $(1, 1)$.
- (b) Determine with reasons, which of the following equations best describe the differential equation.
 - A. $y' = x + 1$ B. $y' = 2x + 1$
 - C. $y' = y + 1$ D. $y' = y - 1$.
- (c) For the equation you have chosen, state the equation of the isocline with gradient $1/2$. Draw this isocline on the diagram given.

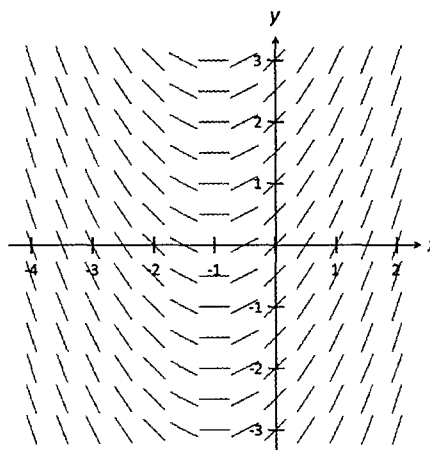

6. The accompanying diagram shows the slope field of a differential equation.

- (a) Estimate where the integral curve with initial condition $(1, -1)$ crosses the y -axis
- (b) Determine with reasons, which of the following equations best describe the differential equation.
 - A. $y' = 2y - 2$ B. $y' = x + 1$
 - C. $y' = y - 1$ D. $y' = x - 1$.
- (c) For the equation you have chosen, sketch the isocline with gradient $1/3$.

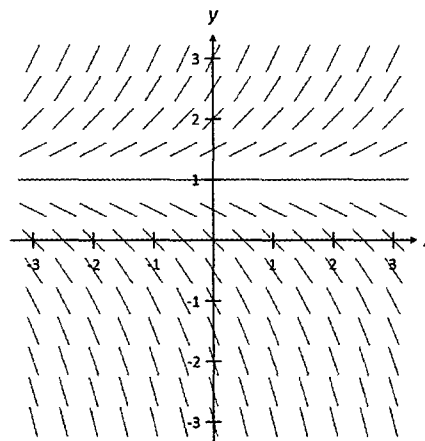

7. Suggest with reasons a differential equation that corresponds to the given slope fields.

(a)

(b)

(c)

(d)

(e)

(f)

17 Rectilinear Motion

17.1 Displacement, Velocity and Acceleration

- This section reviews and extends the concepts of rectilinear motion introduced in Mathematics Methods Units 1, 2, 3 & 4.
- Consider a particle P travelling in a straight line (undergoing rectilinear motion) starting from a fixed point O.
- Let $x(t)$ denote the displacement of P from O at any time t .
Let $v(t)$ and $a(t)$ respectively denote the velocity and acceleration of P at any time t .
- The distance between P and O at any time t is given by $|x(t)|$.
- The change in displacement between $t = a$ and $t = b$ is $\int_a^b v \, dt$.
- The distance travelled by P in the interval $a \leq t \leq b$ is $\int_a^b |v| \, dt$.
- The velocity of P is $v(t) = \frac{dx}{dt}$ whereas its speed is $|\frac{dx}{dt}|$.
- The acceleration of P is $a(t) = \frac{dv}{dt} = \frac{d^2x}{dt^2}$.

- Applying the chain rule on $\frac{dv}{dt}$:

$$\begin{aligned} \frac{dv}{dt} &= \frac{dv}{dx} \times \frac{dx}{dt} \\ &= v \frac{dv}{dx} \\ &= \frac{d\left(\frac{1}{2}v^2\right)}{dx} \end{aligned}$$

- Hence:

$$\begin{aligned} a(t) &= \frac{dv}{dt} = \frac{d^2x}{dt^2} \\ &= v \frac{dv}{dx} = \frac{d\left(\frac{1}{2}v^2\right)}{dx} \end{aligned}$$

- The relationship between displacement, velocity and acceleration is described schematically below:

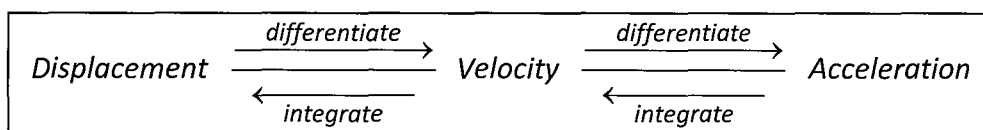

Example 17.1

A particle travels in a straight line such that its velocity at time t (seconds) is given by $v = 3t^2 - 4$ (ms^{-1}). The particle starts from rest from the origin O.

- (a) Find acceleration of the particle when it is next at O.
 (b) Find the change in displacement between $t = 0$ and $t = 3$ seconds.
 (c) Find the distance travelled in the first 3 seconds.

Solution:

$$(a) \text{ Displacement } x = \int 3t^2 - 4 \, dt = t^3 - 4t + C$$

$$x(0) = 0 \Rightarrow C = 0 \Rightarrow x = t^3 - 4t$$

$$\text{When the particle is at O: } \quad x = 0 \Rightarrow t^3 - 4t = 0$$

$$t = 0 \text{ and } 2 \text{ (reject } t = -2)$$

Hence, the particle is next at O when $t = 2$ seconds.

$$a = \frac{dv}{dt} = 6t. \text{ Hence, } a(2) = 12 \text{ ms}^{-2}.$$

$$(b) \text{ Change in displacement} = \int_0^3 3t^2 - 4 \, dt = 15 \text{ m.}$$

$$(c) \text{ Distance travelled} = \int_0^3 |3t^2 - 4| \, dt = 21.16 \text{ m.}$$

Example 17.2

The acceleration of a body moving in a straight line at time t seconds is given by $a = 4t + 1$. Find x , the displacement of the particle from a fixed point O at time t given that the particle starts from O with a velocity of 5 ms^{-1} .

Solution:

$$\text{Integrate with respect to } t: \quad \frac{dx}{dt} = \int 4t + 1 \, dt$$

$$= 2t^2 + t + C$$

$$\text{When } t = 0, \text{ velocity } \frac{dx}{dt} = 5 \Rightarrow C = 5.$$

$$\text{Hence: } \quad \frac{dx}{dt} = \int 2t^2 + t + 5 \, dt$$

$$\text{Integrate with respect to } t: \quad x = \frac{2t^3}{3} + \frac{t^2}{2} + 5t + K$$

$$\text{When } t = 0, x = 0 \Rightarrow K = 0$$

$$\text{Hence: } \quad x = \frac{2t^3}{3} + \frac{t^2}{2} + 5t$$

Example 17.3

A particle P moves along a straight line. Its displacement (metres) from the fixed point O is given by $x(t)$ where t is time in seconds. The acceleration a of the particle is given by

$a(t) = 9 - 4v^2$ where $v(t)$ is the velocity of the particle. Also, $x(0) = v(0) = 0$ and $v(t) \geq 0 \forall t$.

(a) Find v in terms of x . Hence, determine the limiting value for v .

(b) Find v in terms of t . Hence, describe the motion of P.

Solution:

$$(a) \text{ Since } a(t) = v \frac{dv}{dx}, \quad v \frac{dv}{dx} = 9 - 4v^2$$

$$\text{Separate the variables:} \quad \frac{v}{9 - 4v^2} dv = dx$$

$$\text{Integrate:} \quad \int \frac{v}{9 - 4v^2} dv = \int 1 dx$$

$$-\frac{1}{8} \ln(9 - 4v^2) = x + C$$

$$\ln(9 - 4v^2) = -8x + K$$

$$9 - 4v^2 = Ae^{-8x}$$

$$\text{Initial Condition } x = 0, v = 0: \quad A = 9$$

$$\text{Hence:} \quad 4v^2 = 9 - 9e^{-8x}$$

$$v = \frac{3}{2} \sqrt{1 - e^{-8x}} \quad \text{as } v(t) \geq 0 \forall t.$$

As $x \rightarrow \infty, v \rightarrow \frac{3}{2}$. Hence, limiting value of v is $\frac{3}{2} \text{ ms}^{-1}$.

$$(b) a(t) = 9 - 4v^2, \quad \frac{dv}{dt} = 9 - 4v^2$$

$$\text{Separate the variables:} \quad \frac{1}{9 - 4v^2} dv = dt$$

$$\text{Integrate:} \quad \int \frac{1}{9 - 4v^2} dv = \int 1 dt$$

Decompose integrand into its partial fractions:

$$\frac{1}{9 - 4v^2} \equiv \frac{1}{(3 - 2v)(3 + 2v)} \equiv \frac{A}{3 - 2v} + \frac{B}{3 + 2v}$$

$$\text{Hence:} \quad 1 \equiv A(3 + 2v) + B(3 - 2v)$$

$$A = B = \frac{1}{6}$$

$$\text{Therefore:} \quad \frac{1}{6} \int \frac{1}{3 - 2v} + \frac{1}{3 + 2v} dv = \int 1 dt$$

$$-\frac{1}{12} \ln \left| \frac{3 - 2v}{3 + 2v} \right| = t + C$$

(b) Initial Condition $t = 0, v = 0$:

$$C = 0$$

Hence:

$$\left| \frac{3-2v}{3+2v} \right| = e^{-12t}$$

As $0 \leq v < \frac{3}{2}$:

$$\frac{3-2v}{3+2v} = e^{-12t}$$

$$v = \frac{3(1-e^{-12t})}{2(1+e^{-12t})}$$

Therefore, as $t \rightarrow \infty$, P moves further and further away from O travelling at a constant speed of $\frac{3}{2} \text{ ms}^{-1}$.

Example 17.4

A particle P moves along a straight line. Its displacement (metres) from the fixed point O is given by $x(t)$ where t is time in seconds. The acceleration a of the particle is given by $a(t) = 2 - 4x$. Also, $x(0) = v(0) = 0$ and $v(t) \geq 0 \forall t$.

(a) Find v in terms of x .(b) Hence, determine the range of values for x and v .**Solution:**

(a) Since $a(t) = v \frac{dv}{dx}$,
$$v \frac{dv}{dx} = 2 - 4x$$

Separate the variables and integrate:
$$\int v \, dv = \int 2 - 4x \, dx$$

$$\frac{v^2}{2} = 2x - 2x^2 + C$$

$$v^2 = 4x - 4x^2 + K$$

Since $x(0) = v(0) = 0$, $\Rightarrow K = 0$.

Hence
$$v = 2\sqrt{x - x^2} \quad \text{since } v(t) \geq 0 \forall t.$$

Alternative Solution to obtain v^2

Use $a(t) = \frac{d\left(\frac{1}{2}v^2\right)}{dx}$. $\Rightarrow \frac{d\left(\frac{1}{2}v^2\right)}{dx} = 2 - 4x$

Separate the variables and integrate:
$$\int 1 \, d\left(\frac{1}{2}v^2\right) = \int 2 - 4x \, dx$$

$$\frac{v^2}{2} = 2x - 2x^2 + C.$$

(b) Clearly $x - x^2 \geq 0. \Rightarrow x(1 - x) \geq 0$
 $\Rightarrow 0 \leq x \leq 1$ metres

Clearly, minimum value for v is 0.

Maximum for $-x^2 + x$ occurs at $x = \frac{1}{2}. \Rightarrow$ Maximum value for $v = 1.$
 $\Rightarrow 0 \leq v \leq 1 \text{ ms}^{-1}.$

Exercise 17.1

- The displacement, s (m), of a particle P moving in a straight line, at time t seconds, from a fixed point O, is given by: $s = -2 + 1.5 \ln(t + 3)$, for $t \geq 0$. Find:
 - the initial displacement of P
 - when the particle is at O
 - the displacement of P at $t = 40$ seconds
 - the distance travelled in the first 40 seconds.
- Particle P travels in a straight line such that its displacement x (metres) from a fixed point O, t seconds after passing O, is given by $x = e^t \sin(t)$. For $0 \leq t \leq \pi$, calculate:
 - when P is instantaneously at rest and its acceleration at this instant
 - the maximum velocity for P (in the positive direction).
- A particle moves along the x -axis, and after t seconds, its position from the origin O is given by $x = 5 + 3 \cos(2t) + 4 \sin(2t)$.
 - Calculate when the body is momentarily at rest.
 - Prove that the acceleration of the particle is given by $a = 20 - 4x$.
- Particle P travels along the x -axis such that at time t ($t \geq 0$) seconds, its displacement x metres from O is given by $x = 16(e^{-t} - e^{-2t})$. Find:
 - the acceleration of P when P is farthest from O
 - the maximum speed of P on its return journey to O.
- A particle P travels along the x -axis in the time interval $0 \leq t \leq \pi$. Its displacement x from the origin O, t seconds later is given by $x = t + \sin(2t)$.
 - Calculate the value of t during which P first changes its direction of motion.
 - Show that P is always on the same side of O.
 - Find when the acceleration of P is zero.
- The velocity of a particle P experiencing rectilinear motion is given by $v = t(t - 2) \text{ ms}^{-1}$.
 - Calculate the velocity of P when $t = 4$ seconds
 - Determine the net change in displacement in P in the first four seconds
 - Calculate the average speed of P during the first four seconds.

7. The velocity of a particle P experiencing rectilinear motion is given by $v = \pi \sin(\pi t) \text{ ms}^{-1}$.
- Find the velocity of P when $t = 2$ seconds.
 - Calculate the time it takes P to travel the first 2 metres.
8. The velocity $v \text{ cms}^{-1}$ of particle P is related to its displacement $x \text{ cm}$ from a fixed point O by the equation $v = 2x + 4$. It is known that P starts off from O and $x \geq 0 \forall t \geq 0$.
- Determine x in terms of time t .
 - Determine its acceleration a in terms of time t .
9. The velocity $v \text{ ms}^{-1}$ of particle P is related to its displacement $x \text{ m}$ from a fixed point O by the equation $v = x^3 - 8$. It is known that P starts off from O.
- Determine its acceleration a when $x = 1 \text{ m}$
 - Determine its displacement when its acceleration is 0.
10. The acceleration of a particle P undergoing rectilinear motion is given by $a = 2t - 3 \text{ ms}^{-2}$. The initial velocity of P is 0 ms^{-1} . Calculate:
- the velocity of P when $t = 4$ seconds
 - the acceleration at the instance P completes the first 4 metres.
11. The acceleration of a particle P undergoing rectilinear motion is given by $a = -4\pi^2 \sin(2\pi t) \text{ ms}^{-2}$. The initial velocity of P is $2\pi \text{ ms}^{-1}$. Calculate:
- the velocity of P when $t = 1.5$ seconds
 - when P has travelled the first 2 metres.
12. The acceleration of a particle P undergoing rectilinear motion is given by $a = \sqrt{1+4t} \text{ ms}^{-2}$. The initial velocity of P is $1/6 \text{ ms}^{-1}$. Calculate:
- the velocity of P when $t = 2$ seconds
 - the net change in displacement in P in the first two seconds.
13. A particle P moves along a straight line. Its velocity $v(t) \text{ ms}^{-1}$ at time t seconds satisfies the equation $\frac{dv}{dt} = 4 - v$. Given that $v(0) = 0$ and $v(t) \geq 0 \forall t$, determine:
- $v(t)$ in terms of t
 - the limiting velocity of P.
14. A particle P starts from rest from the origin and travels along the negative y -axis. Its velocity $v(t) \text{ ms}^{-1}$ at time t seconds satisfies the equation $\frac{dv}{dt} = 10 - 2v$. Find:
- $v(t)$ in terms of t
 - the limiting velocity of P.

15. The velocity v of a body undergoing free fall at time t is given by $\frac{dv}{dt} = g - kv$ where g and k are positive real constants.
- Find v in terms of t given that the body falls from rest.
 - Find the terminal velocity of the object (the velocity as $t \rightarrow \infty$).
16. A particle P starts from rest from the origin O and moves along the positive x -axis. Its displacement (metres) from O is given by $x(t)$ where t is time in seconds. The acceleration a of the particle is given by $a(t) = 25 - 16v^2$ where $v(t)$ is the velocity of the particle. Find v in terms of x . Hence, determine the limiting value for v .
17. A particle P starts from rest from the origin O and moves along the positive y -axis. Its displacement (metres) from O is given by $y(t)$ where t is time in seconds. The acceleration a of the particle is given by $a(t) = 100 - 25v^2$ where $v(t)$ is the velocity of the particle. Find an expression for v in terms of t . Hence, describe the motion of P.
18. The acceleration a of a particle at time t is given by $a = g(1 - k^2v^2)$ where v is the velocity of the particle and g and k are positive real constants. Find v in terms of x given that $x = 0, v = 0$.
19. A particle P moves along a straight line. Its displacement (metres) from the fixed point O is given by $x(t)$ where t is time in seconds. The acceleration a of the particle is given by $a(t) = -9x$. Also, $x = 0, v = 4$.
- Find v in terms of x .
 - Determine the range of values for x and v .
20. A particle P moves along a straight line. Its displacement (metres) from the fixed point O is given by $x(t)$ where t is time in seconds. The acceleration a of the particle is given by $a(t) = 8 - 4x$. Also, $x(0) = v(0) = 0$ and $v(t) \geq 0 \forall t \geq 0$.
- Find v in terms of x .
 - Hence, determine the range of values for x and v .
21. The acceleration (ms^{-1}) of a particle at time t is related to its displacement x at time t by $a = -\frac{8}{x^2}$. The particle starts with velocity 1 ms^{-1} when $x = 16 \text{ m}$.
- Determine the algebraic relation between its velocity and displacement.
 - Determine the algebraic relation between its displacement and time.
22. The acceleration (ms^{-1}) of a particle at time t is related to its displacement x at time t by $a = 8x(x^2 + 1)$. When $t = 0, x = 0$, its velocity $v = -2 \text{ ms}^{-1}$.
- Determine the algebraic relation between its velocity and displacement.
 - Determine the algebraic relation between its displacement and time.

17.2 The Second Order Differential Equation $\frac{d^2x}{dt^2} = -\omega^2 x$

- In this section, we will examine the properties of variables that satisfy the *second order* differential equation $\frac{d^2x}{dt^2} = -\omega^2 x$ where ω is a constant. The solution to this differential equation is established in the example below.

Example 17.5

The variable $x(t)$, satisfies the $\frac{d^2x}{dt^2} = -\omega^2 x$ where ω is a constant.

- (a) Prove that if $v = \frac{dx}{dt}$, then $v^2 = \omega^2 (A^2 - x^2)$ where A is a constant.
 (b) Hence, find the general solution to the differential equation.

Solution:

$$(a) \text{ Since } \frac{d^2x}{dt^2} = v \frac{dv}{dx}: \quad v \frac{dv}{dx} = -\omega^2 x$$

$$\begin{aligned} \text{Separate the variables and integrate: } \int v \, dv &= -\omega^2 \int x \, dx \\ \frac{v^2}{2} &= -\frac{\omega^2 x^2}{2} + \omega^2 C \\ \text{Hence: } v &= -\omega x + \omega A \\ \Rightarrow v &= \omega (A - x) \end{aligned}$$

$$(b) \text{ Clearly } v = \pm \sqrt{\omega^2 A^2 - \omega^2 x^2}. \quad \Rightarrow \frac{dx}{dt} = \pm \sqrt{\omega^2 A^2 - \omega^2 x^2}$$

$$\text{Separate the variables and integrate: } \int \frac{1}{\sqrt{\omega^2 A^2 - \omega^2 x^2}} \, dx = \pm \int 1 \, dt$$

$$\text{Substitute } x = A \sin \theta: \int \frac{1}{\sqrt{\omega^2 A^2 - \omega^2 A^2 \sin^2 \theta}} \times A \cos \theta \, d\theta = \pm \int 1 \, dt$$

$$\frac{1}{\omega} \int 1 \, d\theta = \pm \int 1 \, dt$$

$$\theta = \pm (\omega t + \alpha) \quad \text{where } \alpha \text{ is a constant}$$

$$\text{Hence: } x = A \sin [\pm(\omega t + \alpha)]$$

$$\text{As } \sin (\pm\beta) = \pm \sin (\beta): \quad x = \pm A \sin (\omega t + \alpha).$$

Note:

- If in part (b), the substitution was $x = A \cos \theta$, then the general solution would be $x = \pm A \cos (\omega t + \alpha)$.

17.2.1 Properties of variables satisfying $\frac{d^2x}{dt^2} = -\omega^2 x$

- Consider the variable x such that $\frac{d^2x}{dt^2} = -\omega^2 x$.
- The general solution is of the form $x = \pm A \sin(\omega t + \alpha)$ or $x = \pm A \cos(\omega t + \alpha)$.
- Clearly the general solution x is a sinusoidal function.
 - Hence: $-|A| \leq x \leq |A|$
That is, the values of the variable x varies between $x = -|A|$ and $x = |A|$.
 - The variation of the values of x has amplitude $|A|$.
 - The values of x changes sinusoidally with period $T = \frac{2\pi}{\omega}$.

17.2.2 Simple Harmonic Motion

- If x represents the displacement of a particle P from a fixed point O and $\frac{d^2x}{dt^2} = -\omega^2 x$, then P is said to experience simple harmonic motion.
 - Its acceleration is proportional to its displacement from the fixed point O (mean position) and acts towards the mean position.
 - Its displacement $x = \pm A \sin(\omega t + \alpha)$ or $x = \pm A \cos(\omega t + \alpha)$.
 - If P starts from the mean position, that is $t = 0, x = 0$, then the motion is best modelled by $x = \pm A \sin(\omega t)$.
 - If P starts from an extreme position, that is $t = 0, x = \pm A$, then the motion is best modelled by $x = \pm A \cos(\omega t)$.
 - If P starts from a point which is neither the mean position nor an extreme position then, the motion is best modelled by either $x = \pm A \sin(\omega t + \alpha)$ or $x = \pm A \cos(\omega t + \alpha)$.
 - P moves along a straight line between $x = -|A|$ and $x = |A|$, that is $-|A| \leq x \leq |A|$.
 - The distance travelled in one cycle = $4 \times \text{amplitude} = 4|A|$.
 - The amplitude of the motion is $|A|$ with period $T = \frac{2\pi}{\omega}$.
 - P is to be found at the same point travelling with the same velocity every $\frac{2\pi}{\omega}$ units of time.
 - The frequency of the motion $f = \frac{1}{T} = \frac{\omega}{2\pi}$ cycles per unit time.
 - Its velocity v in terms of its displacement x is given by $v^2 = \omega^2 (A^2 - x^2)$.

Example 17.6

The acceleration of a body is given by $\frac{d^2x}{dt^2} = -9\pi^2 x$, where x (cm) is the displacement of the body from a fixed point O at time t seconds. The body starts from the point $x = 2$ with an initial velocity of $6\pi \text{ cms}^{-1}$. Determine:

- an expression for x in terms of t .
- the amplitude and period of the motion.
- the minimum and maximum speed of the body.
- the speed of the body as it passes O.
- the distance travelled by the body in the first 2 seconds.

Solution:

$$\begin{aligned} \text{(a)} \quad \frac{d^2x}{dt^2} = -9\pi^2 x &\Rightarrow \omega = 3\pi. \text{ Hence,} & x = A \sin(3\pi t + \alpha) \\ t = 0, x = 2 & & \Rightarrow A \sin \alpha = 2 & \text{I} \\ v = \frac{dx}{dt} = 3\pi A \cos(3\pi t + \alpha) & & \\ v(0) = 6\pi &\Rightarrow 6\pi = 3\pi A \cos \alpha & \Rightarrow A \cos \alpha = 2 & \text{II} \end{aligned}$$

$$\text{Divide I with II} \qquad \tan \alpha = 1 \Rightarrow \alpha = \frac{\pi}{4}$$

$$\text{Hence:} \qquad A \sin \frac{\pi}{4} = 2 \Rightarrow A = 2\sqrt{2}.$$

$$\text{Therefore:} \qquad x = 2\sqrt{2} \sin\left(3\pi t + \frac{\pi}{4}\right).$$

$$\text{(b) Amplitude of motion} = 2\sqrt{2} \text{ cm. Period of motion} = \frac{2\pi}{3\pi} = \frac{2}{3} \text{ seconds.}$$

$$\text{(c) } v = \frac{dx}{dt} = 3\pi \times 2\sqrt{2} \cos\left(3\pi t + \frac{\pi}{4}\right)$$

$$\text{Hence, } 0 \leq |v| \leq 6\pi\sqrt{2} \text{ cms}^{-1}.$$

$$\text{(d) } v^2 = \omega^2 (A^2 - x^2) \Rightarrow v^2 = 9\pi^2 (8 - x^2).$$

$$\text{When } x = 0: \quad \text{speed } |v| = 6\pi\sqrt{2} \text{ cms}^{-1}.$$

$$\text{(e) Distance travelled} = \int_0^2 \left| 6\pi\sqrt{2} \cos\left(3\pi t + \frac{\pi}{4}\right) \right| dt = 24\sqrt{2} \text{ cm.}$$

$$\text{Alternatively, the time interval of 2 seconds covers } \frac{2}{\left(\frac{2}{3}\right)} = 3 \text{ cycles.}$$

$$\text{Distance covered in 3 cycles} = 3 \times (4 \times 2\sqrt{2}) = 24\sqrt{2} \text{ cm.}$$

Example 17.7

A car is parked at the long-term car park of an airport. The temperature difference θ °C between the temperature inside the car and the mean outside temperature of 25 °C, t hours after 12 noon, is modelled by the equation $\frac{d^2\theta}{dt^2} = -\left(\frac{\pi}{12}\right)^2 \theta$. The temperature inside the car at 9 pm and 3 am are respectively 25 °C and 5 °C.

- (a) Show that $\theta = A \cos(\omega t + \alpha)$, stating the values of A , ω and α .
- (b) State the period and range of the temperature fluctuations.
- (c) Find the maximum temperature inside the car and state when this first occurs.
- (d) Find the length of time in a day when the temperature inside the car is above 40 °C.

Solution:

(a) $\frac{d^2\theta}{dt^2} = -\left(\frac{\pi}{12}\right)^2 \theta \Rightarrow \omega = \frac{\pi}{12} \Rightarrow \theta = A \cos\left(\frac{\pi t}{12} + \alpha\right)$.

At $t = 9$, $\theta = 25 - 25 = 0 \Rightarrow A \cos\left(\frac{3\pi}{4} + \alpha\right) = 0$
 $\frac{3\pi}{4} + \alpha = \frac{\pi}{2} \Rightarrow \alpha = -\frac{\pi}{4}$

At $t = 15$, $\theta = 5 - 25 = -20 \Rightarrow A \cos\left(\frac{5\pi}{4} - \frac{\pi}{4}\right) = -20 \Rightarrow A = 20$

Therefore: $\theta = 20 \cos\left(\frac{\pi t}{12} - \frac{\pi}{4}\right)$.

(b) Period = $\frac{2\pi}{\left(\frac{\pi}{12}\right)} = 24$ hours. Range = $2 \times 20 = 40$ °C.

(c) Since, $\theta = 20 \cos\left(\frac{\pi t}{12} - \frac{\pi}{4}\right)$, maximum value for θ is 20.

Therefore, the maximum temperature is $20 + 25 = 45$ °C.

This occurs when $\cos\left(\frac{\pi t}{12} - \frac{\pi}{4}\right) = 1$

$\Rightarrow \frac{\pi t}{12} = \frac{\pi}{4} \Rightarrow t = 3$, i.e. at 3 pm.

(d) Graph $\theta = 20 \cos\left(\frac{\pi t}{12} - \frac{\pi}{4}\right)$.

Temperature is above 40 °C

$\Rightarrow \theta$ is 15 °C above mean.

From graph drawn $\theta > 15$,
for $0.2394 < t < 5.7606$.

That is, for 5.52 hours or 5 hours 31 min.

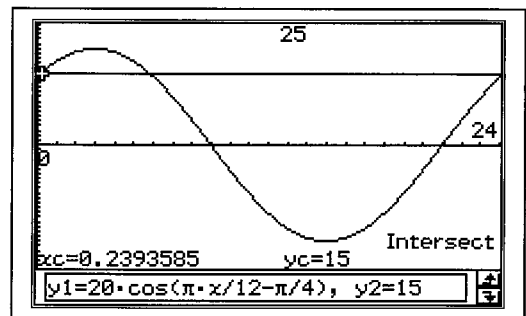

Example 17.8

The depth of water level $h(t)$ metres at a jetty is graphed against time (t hours) and shown in the accompanying diagram. The height, y , of the water surface above the mean

water level satisfies the equation $\frac{d^2y}{dt^2} = -n^2 y$.

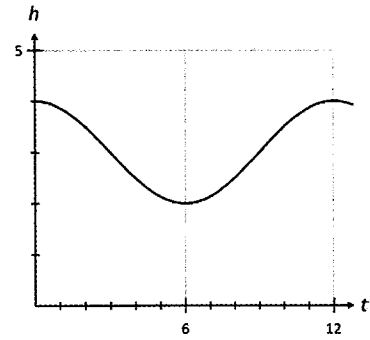

- (a) State the depth of the mean water level.
- (b) Find an expression for $y(t)$.
Hence, find an expression for $h(t)$ in terms of $y(t)$.
- (c) Find the time interval between two consecutive occasions when the water level is at a depth of 3.5 m.
- (d) For 60% of the period, the water level exceeds a metres. Find a .

Solution:

(a) From the graph shown, depth of mean water level is 3m.

(b) Let $y = A \cos (nt + \alpha)$

From the graph, amplitude = 1 $\Rightarrow A = 1$

From the graph, period = 12 hours $\Rightarrow 12 = \frac{2\pi}{n} \Rightarrow n = \frac{\pi}{6}$

$t = 0, y = 1 \Rightarrow 1 = \cos \alpha \Rightarrow \alpha = 0$

Hence, $y = \cos \left(\frac{\pi t}{6} \right)$

$\Rightarrow h = 3 + \cos \left(\frac{\pi t}{6} \right)$

(c) When the water level is at a depth of 3.5 metres:

$3 + \cos \left(\frac{\pi t}{6} \right) = 3.5$

Hence $t = 2, 10$ hours

Therefore, the required time interval is 8 hours.

solve $\left\{ 3 + \cos \left(\frac{\pi \cdot t}{6} \right) = 3.5, t \mid 0 \leq t \leq 12 \right.$
{t=2, t=10}

(d) 60% of period = $12 \times 0.6 = 7.2$ hours.
That is, the water level is above a m for 7.2 hours.
 \Rightarrow The water level is below a m for 4.8 hours.

The curve $h = 3 + \cos \left(\frac{\pi t}{6} \right)$ is symmetrical

about $t = 6$.

Hence, the water level is below a m for $6 - 2.4 \leq t \leq 6 + 2.4 \Rightarrow 3.6 \leq t \leq 8.4$.

Therefore, $a = 3 + \cos \left(\frac{\pi \times 8.4}{6} \right)$
 $= 2.69098 \approx 2.69$ metres.

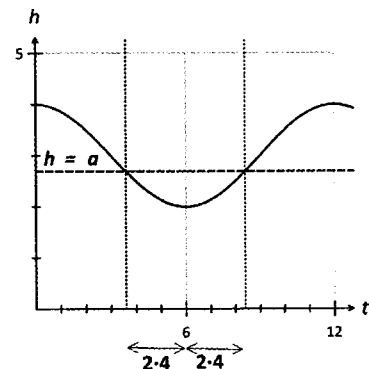

Exercise 17.2

1. Given that $\frac{d^2x}{dt^2} = -4x$, $x(0) = 0$ and $x'(0) = 20$, find x in terms of t .
2. Given that $\frac{d^2h}{dt^2} = -25\pi^2 h$, $h(0) = 5$ and $h'(0) = 0$, find h in terms of t .
3. Given that $\frac{d^2y}{dt^2} = -9y$, $y(0) = 2$ and $y'(0) = 6\sqrt{3}$, find y in terms of t .
4. Given that $\frac{d^2Q}{dt^2} = -16\pi^2 Q$, $Q(0) = -10$ and $Q'(0) = 40\pi$, find Q in terms of t .
5. The equation of motion of a body is given by $\frac{d^2x}{dt^2} = -4\pi^2 x$, where x (cm) is the displacement of the body from a fixed point O at time t seconds. The body starts from a fixed point O and is instantaneously at rest at $x = 3$ cm when $t = 0.25$ seconds. Find:
 - (a) an expression for x in terms of t
 - (b) the amplitude and period of the motion
 - (c) the velocity of the body at time $t = 2$ seconds
 - (d) t when $x = 1$ cm for $0 < t < 0.5$ seconds.
6. The equation of motion of a body is given by $\frac{d^2x}{dt^2} = -16\pi^2 x$, where x (cm) is the displacement of the body from a fixed point O at time t seconds. Given that $-4 \leq x \leq 4$, and $x = 4$ when $t = 0$, find:
 - (a) an expression for x in terms of t .
 - (b) the velocity of the body at time $t = 4$ seconds
 - (c) the velocity when $x = -2$ cm.
7. The acceleration of a body is given by $\frac{d^2x}{dt^2} = -x$, where x (cm) is the displacement of the body from a fixed point O at time t seconds. It is instantaneously at rest when $t = \pi/6$ s at $x = 10$ cm. Find:
 - (a) an expression for x in terms of t .
 - (b) the minimum and maximum speed of the body.
 - (c) x when the velocity of the body is 5 cm s^{-1} .
8. The equation of motion of body P is $\frac{d^2x}{dt^2} = -\left(\frac{\pi}{2}\right)^2 x$. Given that $\frac{dx}{dt} = 0$ at $x = 4$ cm when $t = 0$ sec., find:
 - (a) the maximum speed and when and where the body achieves maximum speed.
 - (b) the minimum speed and when and where the body achieves minimum speed.
 - (c) the total distance travelled by P during the time interval $2 \leq t \leq 10$ seconds.

9. An object P experiences simple harmonic motion with period 30 seconds and amplitude 2 cm. P starts off from the mean position with a negative velocity.
- Determine the maximum speed and magnitude of the maximum acceleration of P.
 - Determine the position of P when:
 - it is travelling at $\pi/15$ cms⁻¹
 - its acceleration is $(\pi/15)^2$ cms⁻².
10. The mean temperature inside a green house is 15 °C. The temperature difference θ °C about this mean temperature, t hours after 12 midnight, is modelled by the equation $\frac{d^2\theta}{dt^2} = -\left(\frac{\pi}{12}\right)^2 \theta$. The temperature inside the green house at 12 am is 12.5 °C.
- Given that $\theta = 5 \sin(\omega t + \alpha)$, find ω and α .
 - Find the minimum temperature inside the green house and state when this occurs.
 - Find the length of time in a day when the temperature inside the green house exceeds 12.5 °C.
11. The height difference (in metres) between the water surface and the mean water level of 5 metres at a lake is given by $\frac{d^2h}{dt^2} = -\left(\frac{\pi}{14}\right)^2 h$ where t is time in days. The lowest and highest water level is respectively 4.8 m and 5.2 m. The water level at $t = 0$ is 5.1 m.
- Given that $h = A \cos(\omega t + \alpha)$, find the values of A, ω and α .
 - Find h when h is increasing at a rate of $\pi/100$ cm per hour.
 - The height difference exceeds k m for 7 days. Find k .
12. The amount of a certain chemical within a certain mammal's body x (mg) is such that $\frac{d^2x}{dt^2} = -\left(\frac{\pi}{14}\right)^2 x$. The minimum amount of 0.1 mg is attained at $t = 14$ days. It is also known that the maximum amount is 0.5 mg.
- Find an expression relating x with t .
 - Find the rate with which the amount of chemical is changing when:
 - $t = 7$
 - $x = 0.1$ mg.
 - The amount of chemical is less than a mg for 80% of the period. Find a .
13. The body temperature T (Celsius), of a certain reptile varies with time. The maximum temperature of 35 °C is attained at approximately $t = 12$ hours (midnight is $t = 0$). The minimum temperature is 15 °C. The temperature difference from the mean temperature of the reptile is such that $\frac{d^2h}{dt^2} = -\left(\frac{\pi}{12}\right)^2 h$.
- Find the rate of change of the difference in the body temperature from the mean temperature when
 - $T = 20$ °C
 - $\frac{d^2h}{dt^2} = -\left(\frac{\pi}{12}\right)^2$.
 - The percentage of time in a cycle when the temperature exceeds 20 °C.
 - Find the value of k if the temperature exceeds k for 8 hours in a day.

14. The depth of water level $h(t)$ metres at a jetty is graphed against time (t hours) and shown in the accompanying diagram. The height, y , of the water surface above the mean water level, is such that

$$\frac{d^2y}{dt^2} = -k^2 y.$$

- (a) Find an expression for $y(t)$. Hence, find an expression for $h(t)$ in terms of $y(t)$.
 (b) Find the length of time within a cycle, when the water level is rising at a rate above 0.1 metre per hour.
 (c) For 4 hours in a cycle, the rate with which the water level rises exceeds a metres per hour. Determine the value(s) of a .

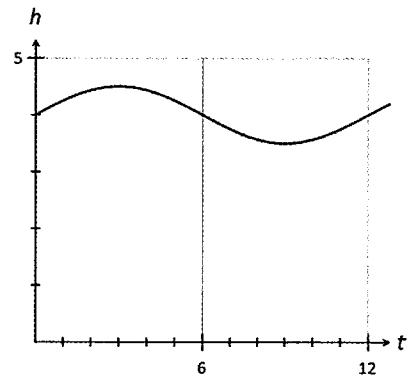

15. The equation of motion of a body is given by $\frac{d^2x}{dt^2} = -\omega^2 x$. Its velocity is 12 cms^{-1} and 4 cms^{-1} respectively at $x = 6 \text{ cm}$ and $x = 10 \text{ cm}$.
 (a) Find x in terms of t . (b) Find the magnitude of the greatest acceleration.

16. The displacement x (metres) of a particle P from a fixed point O is given by $x = 4 \sin(\pi t) + 3 \cos(\pi t)$ where t is time in minutes.
 (a) Show that the motion of P is simple harmonic in nature.
 (b) Find the distance travelled in the first 10 seconds.

17. The displacement (cm) of a particle P moving along the x -axis at time t seconds is given by $x = 5 + 12 \sin(2\pi t) + 5 \cos(2\pi t)$.
 (a) Show that P undergoes simple harmonic motion stating the mean position.
 (b) Find the velocity of P when $x = 8 \text{ cm}$.

18. The path traced by a moving particle P has equation $x^2 + y^2 = 100$. P completes one revolution every 2 minutes. The position of the particle at time t is (x, y) .
 (a) Show that the x -coordinate of P undergoes a change that is simple harmonic in nature. State the period and amplitude of this change.
 (b) Show that the y -coordinate of P undergoes a change that is simple harmonic in nature. State the period and amplitude of this change.

19. A circular disc of diameter 10 cm is spinning on a horizontal axle through its centre. The disc spins at a rate of 1 revolution every 2 seconds. A mark is etched into the edge of the disc at the point P where the vertical displacement between P and the axis of the axle is $y \text{ cm}$.

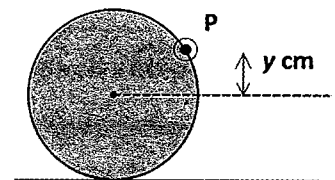

- (a) Show that the vertical displacement y undergoes a change that is simple harmonic in nature. State the period and amplitude of this change.
 (b) Find y when it is changing at a rate of $-\pi \text{ cms}^{-1}$.

18 Vector Calculus

18.1 Derivatives and Integrals of Vector Functions

- Consider the vector function $\mathbf{r}(t) = f(t)\mathbf{i} + g(t)\mathbf{j} + h(t)\mathbf{k}$ where $f(t)$, $h(t)$ and $g(t)$ are differentiable.
- The derivative of $\mathbf{r}(t)$ with respect to t is defined by:

$$\begin{aligned} \mathbf{r}'(t) &= \lim_{\delta t \rightarrow 0} \left[\frac{\mathbf{r}(t + \delta t) - \mathbf{r}(t)}{\delta t} \right] \\ &= \lim_{\delta t \rightarrow 0} \left[\frac{f(t + \delta t) - f(t)}{\delta t} \right] \mathbf{i} + \lim_{\delta t \rightarrow 0} \left[\frac{g(t + \delta t) - g(t)}{\delta t} \right] \mathbf{j} + \lim_{\delta t \rightarrow 0} \left[\frac{h(t + \delta t) - h(t)}{\delta t} \right] \mathbf{k} \\ &= f'(t)\mathbf{i} + g'(t)\mathbf{j} + h'(t)\mathbf{k} \end{aligned}$$

- Similarly the second derivative of $\mathbf{r}(t)$ is given by:

$$\mathbf{r}''(t) = f''(t)\mathbf{i} + g''(t)\mathbf{j} + h''(t)\mathbf{k}.$$

- The indefinite integral of $\mathbf{r}(t)$ with respect to t is given by:

$$\int \mathbf{r}(t) dt = \int f(t) dt \mathbf{i} + \int g(t) dt \mathbf{j} + \int h(t) dt \mathbf{k}.$$

- If $f(t)$, $h(t)$ and $g(t)$ are continuous in the interval $a \leq t \leq b$, then:

$$\int_a^b \mathbf{r}(t) dt = \int_a^b f(t) dt \mathbf{i} + \int_a^b g(t) dt \mathbf{j} + \int_a^b h(t) dt \mathbf{k}.$$

- Hence, the derivative/integral of a vector function is a vector which is obtained by differentiating/integrating each of the components separately.

Example 18.1

Find the first and second derivatives with respect to t for $r = \cos(\pi t) \mathbf{i} + \sin(\pi t) \mathbf{j} + \sin(\pi t) \mathbf{k}$.

Solution:

Differentiate with respect to t :

$$r' = -\pi \sin(\pi t) \mathbf{i} + \pi \cos(\pi t) \mathbf{j} + \pi \cos(\pi t) \mathbf{k}$$

$$r'' = -\pi^2 \cos(\pi t) \mathbf{i} - \pi^2 \sin(\pi t) \mathbf{j} - \pi^2 \sin(\pi t) \mathbf{k}$$

$$= -\pi^2 (\cos(\pi t) \mathbf{i} + \sin(\pi t) \mathbf{j} + \sin(\pi t) \mathbf{k})$$

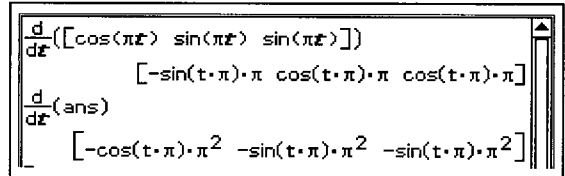

$$\frac{d}{dt}([\cos(\pi t) \quad \sin(\pi t) \quad \sin(\pi t)])$$

$$[-\sin(\pi t) \cdot \pi \quad \cos(\pi t) \cdot \pi \quad \cos(\pi t) \cdot \pi]$$

$$\frac{d}{dt}(\text{ans})$$

$$[-\cos(\pi t) \cdot \pi^2 \quad -\sin(\pi t) \cdot \pi^2 \quad -\sin(\pi t) \cdot \pi^2]$$

Example 18.2

Given $r = 2 \mathbf{i} + 2t \mathbf{j} - \mathbf{k}$, find (a) $\int r(t) dt$ if $r(0) = \mathbf{i} + \mathbf{k}$ (b) $\int_1^2 r(t) dt$.

Solution:

$$(a) \quad \int r(t) dt = \int 2 dt \mathbf{i} + \int 2t dt \mathbf{j} - \int 1 dt \mathbf{k}$$

$$= (2t + a) \mathbf{i} + (t^2 + b) \mathbf{j} - (t + c) \mathbf{k} \quad \text{where } a, b \text{ and } c \text{ are constants.}$$

$$r(0) = \mathbf{i} + \mathbf{k}: \quad \int r(t) dt = (2t + 1) \mathbf{i} + t^2 \mathbf{j} - (t - 1) \mathbf{k}$$

$$(b) \quad \int_0^1 r(t) dt = [2t]_0^1 \mathbf{i} + [t^2]_0^1 \mathbf{j} - [t]_0^1 \mathbf{k}$$

$$= 2 \mathbf{i} + \mathbf{j} - \mathbf{k}$$

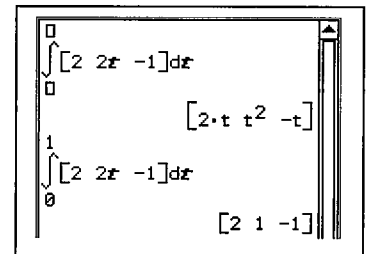

$$\int [2 \quad 2t \quad -1] dx$$

$$[2 \cdot t \quad t^2 \quad -t]$$

$$\int_0^1 [2 \quad 2x \quad -1] dx$$

$$[2 \quad 1 \quad -1]$$

Alternative solution to (a)

$$\int r(t) dt = \int 2 dt \mathbf{i} + \int 2t dt \mathbf{j} - \int 1 dt \mathbf{k}$$

$$= 2t \mathbf{i} + t^2 \mathbf{j} - t \mathbf{k} + C \quad \text{where } C \text{ is a constant vector.}$$

$$r(0) = \mathbf{i} + \mathbf{k}: \quad \int r(t) dt = 2t \mathbf{i} + t^2 \mathbf{j} - t \mathbf{k} + (\mathbf{i} + \mathbf{k})$$

Exercise 18.1

- For each of the following vector functions, determine \mathbf{r}' and \mathbf{r}'' .
 - $\mathbf{r} = \ln(t) \mathbf{i} + e^t \mathbf{j} + t e^{-t} \mathbf{k}$
 - $\mathbf{r} = \sin(2t) \mathbf{i} + \cos(2t) \mathbf{j} + \tan(2t) \mathbf{k}$
 - $\mathbf{r} = \left\langle 1 + \frac{1}{t}, \frac{t}{t+1}, \frac{t}{t-1} \right\rangle$
 - $\mathbf{r} = \langle e^{\cos \pi t}, e^{-\cos \pi t}, e^{\sin \pi t} \rangle$
- Given $\mathbf{r} = (1 - 2t) \mathbf{i} + (t + t^2) \mathbf{j} + 5 \mathbf{k}$ find $\mathbf{r}' \cdot \mathbf{r}''$.
Hence, find t when \mathbf{r}' and \mathbf{r}'' are perpendicular.
- Given $\mathbf{r} = \langle \sin(2t), 2, \cos(2t) \rangle$, find t for $0 \leq t \leq 2\pi$ when \mathbf{r}' and \mathbf{r}'' are perpendicular.
- Given $\mathbf{r} = 2 \sin(t) \mathbf{i} + 3 \cos(t) \mathbf{k}$, find t for $0 \leq t \leq 2\pi$ when \mathbf{r}' and \mathbf{r}'' are perpendicular.
- Given that $\mathbf{r} = \sin(2t) \mathbf{i} + \cos(2t) \mathbf{j} + \sin(2t) \mathbf{k}$ show that $\mathbf{r}'' = -n^2 \mathbf{r}$, where n is a constant.
- Given that $\mathbf{r} = 2 \mathbf{i} + t \mathbf{j} - t^2 \mathbf{k}$, find $|\mathbf{r}|$. Hence, find $\frac{d}{dt} |\mathbf{r}|$.
- Given that $\mathbf{r} = 2t \mathbf{i} + (1 + t) \mathbf{j} + \frac{1}{t+1} \mathbf{k}$, find $\left| \frac{d\mathbf{r}}{dt} \right|$.
- Given that $\mathbf{r} = 2t \mathbf{i} - 4 \mathbf{j} + t^2 \mathbf{k}$, find $\frac{d}{dt} [\mathbf{r} \cdot \mathbf{r}']$ and $\frac{d}{dt} [\mathbf{r}' \cdot \mathbf{r}'']$.
- If $\mathbf{r} = 2t \mathbf{i} + (t^2 - t + 1) \mathbf{j} + (1 - 2t^2) \mathbf{k}$, find the value of t for which $\frac{d}{dt} [\mathbf{r}' \cdot \mathbf{r}''] = 0$.
- If $\mathbf{r} = 2 \sin(t) \mathbf{i} + 3 \cos(t) \mathbf{j}$, find the value of t , $0 \leq t \leq 2\pi$, for which $\frac{d}{dt} [\mathbf{r}' \cdot \mathbf{r}''] = 0$.
- For each $\mathbf{r}(t)$, find $\int_a^b \mathbf{r}(t) dt$ and $\int_a^b |\mathbf{r}(t)| dt$ for the indicated values of a and b .
 - $\mathbf{r}(t) = \langle 0, 2 \cos(t), -3 \sin(t) \rangle$ $a = 0, b = \pi/2$
 - $\mathbf{r}(t) = \left\langle 1 + \frac{1}{t}, 1 - \frac{1}{t}, \frac{1}{1+t} \right\rangle$ $a = 1, b = 2$
- Find $\left| \int_a^b \mathbf{r}(t) dt \right|$ and $\int_a^b |\mathbf{r}(t)| dt$ for the indicated values of a and b .
 - $\mathbf{r} = \langle \sin(t), 0, \cos(t) \rangle$ $a = 0$ and $b = \pi/2$
 - $\mathbf{r} = \langle \sin(2t), -\cos(2t), 2 \sin(t) \rangle$ $a = 0$ and $b = \pi/2$
- Given that $\mathbf{r}' = (1 - 2t) \mathbf{i} + 4 \mathbf{j} + t \mathbf{k}$, find \mathbf{r} given that $\mathbf{r}(0) = \mathbf{i} + \mathbf{j}$.

14. Given that $\mathbf{r}' = \langle -\pi \sin(\pi t), 1, 2\pi \cos(\pi t) \rangle$, find \mathbf{r} given that $\mathbf{r}(0) = \langle 1, 0, -1 \rangle$.
15. Given that $\mathbf{r}'' = \langle 0, 6t, -2 \rangle$, find \mathbf{r} given that $\mathbf{r}'(0) = \langle 0, 0, 0 \rangle$ and $\mathbf{r}(0) = \langle -1, 0, 0 \rangle$.
16. Given that $\mathbf{r}'' = \langle \pi^2 \sin(\pi t), \pi^2 \cos(\pi t), \pi^2 \sin(\pi t) \rangle$, find \mathbf{r} given that $\mathbf{r}'(0) = \langle -\pi, 0, 0 \rangle$ and $\mathbf{r}(0) = \langle 0, 0, 0 \rangle$.
17. Given that $\mathbf{r} = 8t \mathbf{i} - 6t^2 \mathbf{j} + \mathbf{k}$, find $\int_0^1 \mathbf{r} \cdot \mathbf{r}' dt$.

18.2 Displacement, Velocity and Acceleration Vectors

- Let the displacement/position vector of a moving body P at time t be $\mathbf{r}(t)$. Let the corresponding velocity and acceleration vectors be $\mathbf{v}(t)$ and $\mathbf{a}(t)$ respectively.
 - The velocity vector is $\mathbf{v}(t) = \mathbf{r}'(t)$.
 - The speed of P at time t is given by $|\mathbf{v}(t)|$.
 - The acceleration vector is $\mathbf{a}(t) = \mathbf{r}''(t)$.
 - The magnitude of the acceleration at time t is given by $|\mathbf{a}(t)|$.
 - Also, the displacement vector $\mathbf{r}(t) = \int \mathbf{v}(t) dt$
and the velocity vector $\mathbf{v}(t) = \int \mathbf{a}(t) dt$
 - Between the time $t = a$ and $t = b$:
 - $\int_a^b \mathbf{v}(t) dt$ represents the *change in displacement*
 - $\left| \int_a^b \mathbf{v}(t) dt \right|$ represents the *magnitude* of the change of displacement.
 - $\int_a^b |\mathbf{v}(t)| dt$ represents the *distance travelled along the path* traced.

Example 18.3

The velocity of a particle P at time t seconds is given by $\mathbf{v}(t) = \langle 2t, -2t, 4t \rangle \text{ cms}^{-1}$.

- (a) Find the position vector of the particle at any time t given that $\mathbf{r}(0) = \langle 1, 0, -1 \rangle \text{ cm}$.
 (b) Show that the body undergoes constant acceleration.
 (c) Find the magnitude of the change in displacement in the first 10 seconds.
 (d) Find the distance travelled along the path in the first 10 seconds.
 (e) Show that P travels in one direction along a straight line.

State the Cartesian equation of this line.

Solution:

- (a) Integrate with respect to t : $\mathbf{r}(t) = \langle t^2, -t^2, 2t^2 \rangle + \mathbf{C}$, where \mathbf{C} is a constant vector.

$$\text{But } \mathbf{r}(0) = \langle 1, 0, -1 \rangle \Rightarrow \mathbf{C} = \langle 1, 0, -1 \rangle$$

$$\text{Therefore } \mathbf{r}(t) = \langle (t^2 + 1), -t^2, 2t^2 - 1 \rangle$$

- (b) Differentiate with respect to t : $\mathbf{a}(t) = \langle 2, -2, 4 \rangle$.

Since, $\mathbf{a}(t)$ is independent of time t , the acceleration is constant.

$$\begin{aligned} \text{(c) Change in displacement} &= \int_0^{10} \langle 2t, -2t, 4t \rangle dt \\ &= \left[\langle t^2, -t^2, 2t^2 \rangle \right]_0^{10} \\ &= \langle 100, -100, 200 \rangle \end{aligned}$$

$$\begin{aligned} \text{Hence, magnitude of change in displacement} &= |\langle 100, -100, 200 \rangle| \\ &= 100\sqrt{6} \text{ cm.} \end{aligned}$$

$$\begin{aligned} \text{(d) Distance travelled along path} &= \int_0^{10} |\langle 2t, -2t, 4t \rangle| dt \\ &= \sqrt{6} \int_0^{10} 2t dt \\ &= \sqrt{6} \left[t^2 \right]_0^{10} \\ &= 100\sqrt{6} \text{ cm.} \end{aligned}$$

- (e) Since, change in displacement = distance travelled along the path, P must be travelling along a line with no reversal of direction.

$$\begin{aligned} \text{Parametric equation of path: } \quad x &= t^2 + 1 \\ y &= -t^2 \\ z &= 2t^2 - 1 \end{aligned}$$

$$\text{Hence, Cartesian equation is } x - 1 = -y = \frac{z + 1}{2}$$

(This confirms that the path is indeed a line.)

Example 18.4

The acceleration of a particle P at time t seconds is given by $\mathbf{a}(t) = \langle 6t, 0, 0 \rangle \text{ cms}^{-2}$.

Its initial displacement and velocity are $\langle -1, 1, -2 \rangle \text{ cm}$ and $\langle 0, 0, 1 \rangle \text{ cms}^{-1}$ respectively.

- Find the position vector of P when it crosses the y - z plane.
- Find the velocity of P as it crosses the x - y plane and state the angle the velocity vector makes with the x - y plane.
- Find the magnitude of the change in displacement in the first 2 seconds.
- Find the distance travelled along the path in the first 2 seconds.

Solution:

(a) Integrate with respect to t : $\mathbf{v}(t) = \langle 3t^2, 0, 0 \rangle + \mathbf{C}$.
 $\mathbf{v}(0) = \langle 0, 0, 1 \rangle \Rightarrow \mathbf{v}(t) = \langle 3t^2, 0, 1 \rangle$.

Integrate with respect to t : $\mathbf{r}(t) = \langle t^3, 0, t \rangle + \mathbf{K}$.
 $\mathbf{r}(0) = \langle -1, 1, -2 \rangle \Rightarrow \mathbf{r}(t) = \langle t^3 - 1, 1, t - 2 \rangle$.
 When it crosses the y - z plane, x -component of $\mathbf{r} = 0$.
 $\Rightarrow t^3 - 1 = 0 \Rightarrow t = 1$.

Hence, $\mathbf{r}(1) = \langle 0, 1, -1 \rangle \text{ cm}$.

(b) When it crosses the x - y plane, z -component of $\mathbf{r} = 0$.
 $\Rightarrow t - 2 = 0 \Rightarrow t = 2$.
 Hence, $\mathbf{v}(2) = \langle 12, 0, 1 \rangle$.

Vector normal to the x - y plane is $\langle 0, 0, 1 \rangle$.

Angle $\mathbf{v}(2)$ makes with $\langle 0, 0, 1 \rangle$ is $85.2363 \approx 85.2^\circ$.

Hence, angle $\mathbf{v}(2)$ makes with x - y plane $\approx 90 - 85.2 \approx 4.8^\circ$.

(c) Change in displacement $= \int_0^2 \langle 3t^2, 0, 1 \rangle dt$
 $= \left[\langle t^3, 0, t \rangle \right]_0^2$
 $= \langle 8, 0, 2 \rangle$

Hence, magnitude of change in displacement $= |\langle 8, 0, 2 \rangle|$
 $= 2\sqrt{17} \approx 8.25 \text{ cm}$.

(d) Distance travelled along path $= \int_0^2 |\langle 3t^2, 0, 1 \rangle| dt$
 $= \int_0^2 \sqrt{9t^4 + 1} dt$
 $= 8.6303 \approx 8.63 \text{ cm}$

Exercise 18.2

- The velocity of a moving body P at time t is given by $\mathbf{v}(t)$.
Given $\mathbf{r}(a)$, determine the position of P at the indicated times.
 - $\mathbf{v}(t) = 2\mathbf{i} + 4\mathbf{j} - 2\mathbf{k}$, $\mathbf{r}(0) = 0\mathbf{i} + 0\mathbf{j} + 2\mathbf{k}$, $t = 5$.
 - $\mathbf{v}(t) = \langle -t, 2t, 4t \rangle$, $\mathbf{r}(0) = \langle 0, 2, 2 \rangle$, $t = 4$.
 - $\mathbf{v}(t) = \langle (1 + 2t), (1 - 2t), \frac{1}{t+1} \rangle$, $\mathbf{r}(0) = \langle -2, 0, 1 \rangle$, $t = 1$.
 - $\mathbf{v}(t) = \begin{pmatrix} \pi \sin 2\pi t \\ \pi \cos 2\pi t \\ \pi \sin^2 \pi t \end{pmatrix}$, $\mathbf{r}(0) = \begin{pmatrix} -1 \\ 1 \\ 0 \end{pmatrix}$, $t = \frac{1}{2}$.
- The displacement and acceleration of a particle P at time t are $\mathbf{r}(t)$ and $\mathbf{a}(t)$ respectively.
For the given conditions, find the displacement of the body at the indicated times.
 - $\mathbf{a}(t) = \langle 0, 0, 10 \rangle$, $\mathbf{v}(0) = \langle 1, -1, 5 \rangle$, $\mathbf{r}(0) = \langle 2, 1, 0 \rangle$, $t = 5$
 - $\mathbf{a}(t) = -2\mathbf{i} + 2\mathbf{j}$, $\mathbf{v}(0) = 0\mathbf{i} + 0\mathbf{j} + 2\mathbf{k}$, $\mathbf{r}(0) = \langle -1, -1, 2 \rangle$, $t = 10$
 - $\mathbf{a}(t) = \langle \sin(t), 0, -\cos(t) \rangle$, $\mathbf{v}(0) = \langle 2, 1, -1 \rangle$, $\mathbf{r}(0) = \langle 1, 1, 0 \rangle$, $t = 2\pi$
 - $\mathbf{a}(t) = \langle 4 \sin(t), 3 \cos(t), 6t \rangle$, $\mathbf{v}(0) = \langle 0, 0, 0 \rangle$, $\mathbf{r}(0) = \langle -1, 1, 0 \rangle$, $t = 2\pi$
- The position vector of a particle P, t seconds after projection, is given by
 $\mathbf{r}(t) = 3t\mathbf{i} + (t - t^2)\mathbf{j} + 2\mathbf{k}$, where the components are measured in m.
 - Find the position vector of the point of projection and the speed of projection.
 - Calculate the angle with which P crosses the x - z plane.
 - Show that P undergoes constant acceleration.
 - Determine the distance travelled by P in the first second.
- The position vector of a particle P, t seconds after projection, is given by
 $\mathbf{r}(t) = \langle \sin(t), \cos(t), \sin(t) \rangle$, where the components are measured in m.
 - Show that the acceleration of P is always parallel to its displacement.
 - Determine the angle and speed of impact of P with the x - y plane.
 - Find the change in displacement in the first 2π seconds. Comment on your answer.
- The velocity vector of a particle P, at time t seconds, is given by $\mathbf{v}(t) = \langle t - 1, 0, t - t^2 \rangle$,
where the components are measured in cms^{-1} .
 - Find when P is instantaneously at rest.
 - Calculate the distance travelled by P between the time it starts moving and when it is instantaneously at rest.
 - Determine, when if ever, the velocity is perpendicular to the acceleration.
- A particle P is projected from the origin. The velocity vector of a particle P, at time t seconds, is given by $\mathbf{v}(t) = \langle \sin(t), \cos(t), \sin(t) \rangle \text{ cms}^{-1}$.
 - Calculate the minimum and maximum distance between P and the origin.
 - Calculate when and where, the velocity and acceleration vectors are perpendicular for $0 \leq t \leq 2\pi$.

7. A particle P starts moving from rest from $\langle 1, 2, 1 \rangle$. Its acceleration, at time t seconds, is given by $\mathbf{a}(t) = \langle 2, -2, 2 \rangle \text{ cms}^{-2}$.
- Show that P is never instantaneously at rest in its subsequent motion.
 - Determine the Cartesian equation of the path traced by P.
8. A particle P is projected from $\langle 0, 1, 2 \rangle$ with velocity $\langle -4, 1, -2 \rangle \text{ ms}^{-1}$. The acceleration of P, at time t seconds, is given by $\mathbf{a}(t) = \langle 2t, 0, 0 \rangle \text{ cms}^{-2}$.
- Calculate the angle between the velocity and acceleration vectors at $t = 1$ second.
 - Determine when and where the velocity and acceleration vectors are perpendicular.
 - Determine the parametric equation of the path traced by P.
9. A particle P starts moving from rest from the origin. Its acceleration at time t seconds, is given by $\mathbf{a}(t) = \langle 0, -2, 4 \rangle \text{ ms}^{-2}$. At the same time, a second particle Q starts moving from $\langle 0, 4, -16 \rangle \text{ m}$ with an initial velocity of $\langle 0, -4, 0 \rangle \text{ ms}^{-1}$ and with a constant acceleration of $\langle 0, 0, 12 \rangle \text{ ms}^{-2}$.
- Calculate when and where P and Q collide.
 - Calculate the angle of impact between P and Q.
10. A particle P starts moving from the point $\langle 1, -1, -1 \rangle \text{ m}$ with an initial velocity of $\langle 1, 0, 1 \rangle \text{ ms}^{-1}$. Its acceleration at time t seconds, is given by $\mathbf{a}(t) = \langle 0, 2, 0 \rangle \text{ ms}^{-2}$. At the same time, a second particle Q starts moving from $\langle 1, -1, -2 \rangle \text{ m}$ with an initial velocity of $\langle 1, 0, 2 \rangle \text{ ms}^{-1}$ and with an acceleration of $\langle 0, 6t, 0 \rangle \text{ ms}^{-2}$.
- Calculate when and where P and Q collide.
 - Calculate the angle of impact between P and Q.

18.3 Motion in a plane (2-dimensions)

- In this section, we will examine in greater detail, motion in two-dimensions.
- Let the displacement/position vector of a moving body P at time t be $\mathbf{r}(t) = \langle f(t), g(t) \rangle$.
 - The velocity vector is $\mathbf{v}(t) = \mathbf{r}'(t) = \langle f'(t), g'(t) \rangle$.
 - The direction of the velocity vector is given by θ , where $\tan \theta = \frac{g'(t)}{f'(t)}$.
 - The acceleration vector is $\mathbf{a}(t) = \mathbf{r}''(t) = \langle f''(t), g''(t) \rangle$.
 - The direction of the acceleration vector is given by α , where $\tan \alpha = \frac{g''(t)}{f''(t)}$.

18.3.1 Circular and Elliptical Motion

- Let the position vector of a moving particle P at time t be

$$\mathbf{r} = \langle a \sin \omega t + p, b \cos \omega t + q \rangle.$$

- The parametric equation for the path traced by P is:

$$\begin{aligned} x &= a \sin \omega t + p & y &= b \cos \omega t + q \\ \Rightarrow \sin \omega t &= \frac{x-p}{a} & \cos \omega t &= \frac{y-q}{b} \\ \sin^2 \omega t + \cos^2 \omega t &= 1 & \Rightarrow & \frac{(x-p)^2}{a^2} + \frac{(y-q)^2}{b^2} = 1. \end{aligned}$$

- Hence, the path traced by P is an ellipse.

If $a = b$, then the path is a circle with equation $(x-p)^2 + (y-q)^2 = a^2$.

- The velocity and acceleration vectors for P are respectively:

$$\mathbf{v} = \langle a\omega \cos \omega t, -b\omega \sin \omega t \rangle \quad \text{and} \quad \mathbf{a} = \langle -a\omega^2 \sin \omega t, -b\omega^2 \cos \omega t \rangle.$$

- Clearly $\mathbf{a} = -\omega^2 \mathbf{r}$.

That is, \mathbf{a} is parallel to \mathbf{r} but in an opposing direction.

- The scalar product $\mathbf{a} \cdot \mathbf{v} = \omega^3 (b^2 - a^2) \sin \omega t \cos \omega t$
 $= \frac{1}{2} \omega^3 (b^2 - a^2) \sin 2\omega t$

- If the path is a circle, then $a = b$ and $\mathbf{a} \cdot \mathbf{v} = \mathbf{r} \cdot \mathbf{v} = 0 \quad \forall t$.

- If the path is an ellipse, then $a \neq b$

$$\text{and } \mathbf{a} \cdot \mathbf{v} = \mathbf{r} \cdot \mathbf{v} = 0 \text{ for } t = \frac{n\pi}{2} \text{ where } n \in \mathbb{Z}^+.$$

- Uniform Circular Motion

- $\mathbf{a} = -\omega^2 \mathbf{r}$ where $\mathbf{r} = \langle \pm a \sin \omega t + p, \pm a \cos \omega t + q \rangle$.

- $\mathbf{a} \cdot \mathbf{v} = \mathbf{r} \cdot \mathbf{v} = 0 \quad \forall t$.

- Period of motion = $\frac{2\pi}{\omega}$.

- Elliptical motion

- $\mathbf{a} = -\omega^2 \mathbf{r}$ where $\mathbf{r} = \langle \pm a \sin \omega t + p, \pm b \cos \omega t + q \rangle$ where $a \neq b$.

- $\mathbf{a} \cdot \mathbf{v} = \mathbf{r} \cdot \mathbf{v} = 0$ for $t = \frac{n\pi}{2}$ where $n \in \mathbb{Z}^+$.

- Period of motion = $\frac{2\pi}{\omega}$.

- Particles undergoing circular and elliptical motion share the same equation of motion $\mathbf{a} = -\omega^2 \mathbf{r}$ with the same period.

- The difference is that for circular motion $\mathbf{a} \cdot \mathbf{v} = \mathbf{r} \cdot \mathbf{v} = 0$ all the time whereas for elliptical motion $\mathbf{a} \cdot \mathbf{v} = \mathbf{r} \cdot \mathbf{v} = 0$ for only some of the time.

Example 18.5

The position vector of P at time t seconds is given by $\mathbf{r}(t) = \langle 2 \cos t, 3 \sin t \rangle$ cm.

- (a) Find the times when the velocity is perpendicular to the acceleration for $0 \leq t \leq 2\pi$.
- (b) Find the minimum and maximum speed of P and state where and when these speeds occur for $0 \leq t \leq 2\pi$.
- (c) Sketch the path traced by P indicating its direction of motion. Locate on your graph the locations where P is losing speed and picking up speed for $0 \leq t \leq 2\pi$.
- (d) Comment on your answers in (a), (b) and (c).

Solution:

(a) Differentiating $\mathbf{r}(t)$: $\mathbf{v}(t) = \langle -2 \sin t, 3 \cos t \rangle$

Differentiating $\mathbf{v}(t)$: $\mathbf{a}(t) = \langle -2 \cos t, -3 \sin t \rangle$

$$\mathbf{a} \cdot \mathbf{v} = 0 \quad \Rightarrow \quad 5 \sin t \cos t = 0$$

$$2.5 \sin 2t = 0$$

$$t = 0, \frac{\pi}{2}, \pi, \frac{3\pi}{2}, 2\pi.$$

(b) Speed for \mathbf{v} : $|\mathbf{v}| = \sqrt{4 \sin^2 t + 9 \cos^2 t}$

$$= \sqrt{4 \sin^2 t + 9(1 - \sin^2 t)}$$

$$= \sqrt{9 - 5 \sin^2 t}$$

Hence, minimum speed = 2 cms^{-1} when $\sin t = 1$.

That is, when $t = \frac{\pi}{2}$ and $\frac{3\pi}{2}$ at $\langle 0, 3 \rangle$ and $\langle 0, -3 \rangle$ respectively.

Maximum speed = 3 cms^{-1} when $\sin t = 0$.

That is, when $t = 0$ and 2π at $\langle 2, 0 \rangle$ and when $t = \pi$ at $\langle -2, 0 \rangle$.

(c)

When $t = 0$, $\mathbf{r} = \langle 2, 0 \rangle$

When $t = 0^+$, $\mathbf{r} = \langle 2^-, 0^+ \rangle$.

Hence, P moves in an anti-clockwise direction from $\langle 2, 0 \rangle$.

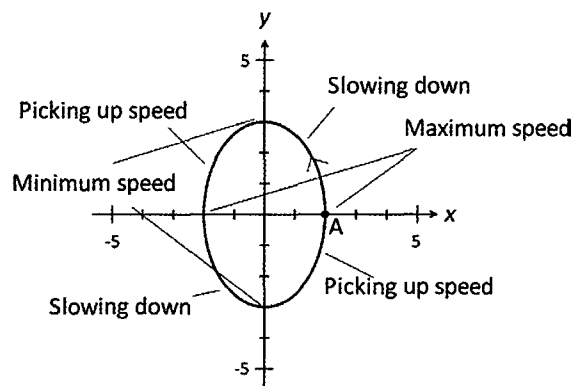

- (d) The maximum and minimum speeds occur when $\mathbf{v}(t)$ and $\mathbf{a}(t)$ are perpendicular. Maximum speed occurs when P is nearest the origin and minimum speed occurs when P is furthest from the origin.

Example 18.6

A particle P starts from $\langle 2, 1 \rangle$ cm with a velocity of $\langle 0, -4\pi \rangle$ cms⁻¹. The acceleration vector of P at time t seconds is given by $\mathbf{a}(t) = \langle -4\pi^2 \cos \pi t, 4\pi^2 \sin \pi t \rangle$ cms⁻².

- (a) Find the direction P is heading when $t = \frac{1}{3}$ seconds.
 (b) Show that P is travelling with constant speed.
 (c) Determine the Cartesian equation of the path traced by P.
 (d) Calculate the distance travelled in 5 seconds.

Solution:

(a) Anti-differentiating $\mathbf{a}(t)$: $\mathbf{v}(t) = \langle -4\pi \sin \pi t, -4\pi \cos \pi t \rangle + \mathbf{C}$

$$\mathbf{v}(0) = \langle 0, -4\pi \rangle \Rightarrow \mathbf{C} = \langle 0, 0 \rangle.$$

Hence: $\mathbf{v}(t) = \langle -4\pi \sin \pi t, -4\pi \cos \pi t \rangle$

$$\mathbf{v}\left(\frac{1}{3}\right) = \left\langle -\frac{4\pi\sqrt{3}}{2}, -2\pi \right\rangle.$$

Direction of $\mathbf{v}\left(\frac{1}{3}\right)$ is given by $\tan \theta = \frac{-2\pi}{-\left(\frac{4\pi\sqrt{3}}{2}\right)}$

That is $\theta = \tan^{-1} \frac{1}{\sqrt{3}}$ in Quadrant 3.

Hence, direction of P = $-\frac{5\pi}{6}$ or -150° .

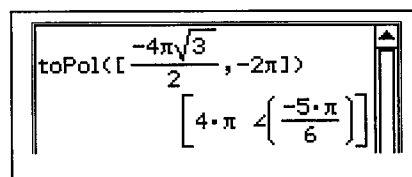

(b) Speed = $|\langle -4\pi \sin \pi t, -4\pi \cos \pi t \rangle|$
 $= \sqrt{16\pi^2(\sin^2 \pi t + \cos^2 \pi t)} = 4\pi$

Hence, P travels with constant speed.

(c) Anti-differentiate $\mathbf{v}(t)$: $\mathbf{r}(t) = \langle 4 \cos \pi t, -4 \sin \pi t \rangle + \mathbf{K}$

$$\mathbf{r}(0) = \langle 2, 1 \rangle \Rightarrow \mathbf{K} = \langle -2, 1 \rangle$$

Hence: $\mathbf{r}(t) = \langle 4 \cos \pi t - 2, -4 \sin \pi t + 1 \rangle$

Parametric equation of path:

$$\begin{aligned} x &= 4 \cos \pi t - 2 & y &= -4 \sin \pi t + 1 \\ \Rightarrow \cos \pi t &= \frac{x+2}{4} & \sin \pi t &= \frac{1-y}{4} \end{aligned}$$

Therefore: $\left(\frac{x+2}{4}\right)^2 + \left(\frac{1-y}{4}\right)^2 = 1.$

Cartesian equation of path is $(x+2)^2 + (y-1)^2 = 16$

(d) Period of motion is $\frac{2\pi}{\pi} = 2$ seconds.

5 seconds covers 2.5 cycles or 2.5 circular revolutions of radius 4 cm.

Hence, distance travelled = $2.5 \times 2 \times \pi \times 4 = 20\pi$ cm.

Exercise 18.3

1. The particles P, Q and R each undergo circular motion and have position vectors at time t given by $\mathbf{r}(t) = 2 \sin(\pi t) \mathbf{i} + 2 \cos(\pi t) \mathbf{j}$, $\mathbf{r}(t) = 2 \cos(\pi t) \mathbf{i} + 2 \sin(\pi t) \mathbf{j}$ and $\mathbf{r}(t) = 2 \cos(\pi t) \mathbf{i} - 2 \sin(\pi t) \mathbf{j}$ respectively. Determine the initial positions, the direction of motion (clockwise or anticlockwise) and equation of the paths for each particle.

2. A particle P moves with constant speed along a circle such that its velocity at any time t is given by $\mathbf{v}(t) = \langle \cos(\pi t), \sin(\pi t) \rangle$. Determine:
 - (a) the direction P is travelling at times $t = 1/2, 2/3$ seconds
 - (b) the acceleration of P at time $t = 1$ second
 - (c) the distance travelled by P between $t = 0$ and $t = 1/2$ seconds.

3. A particle P moves with constant speed along a circle such that its velocity at any time t is given by $\mathbf{v}(t) = \langle -\sin(4\pi t), \cos(4\pi t) \rangle$. Determine:
 - (a) the speed of P
 - (b) equation of the path of P and its direction of motion.
 - (c) the distance travelled by P between $t = 1$ and $t = 2$ seconds.

4. Verify that a particle with a position vector at time t given by: $\mathbf{r}(t) = [2 + \cos(t)] \mathbf{i} + [1 + \sin(t)] \mathbf{j}$ undergoes uniform circular motion.

5. The velocity vector of a moving particle P, at time t minutes, is given by, $\mathbf{v}(t) = \langle 2\pi \sin(2\pi t), 2\pi \cos(2\pi t) \rangle$ metres per minute.
 - (a) Find the displacement of P when $t = 1$ minute, given that $\mathbf{r}(0) = \langle -1, 0 \rangle$ m.
 - (b) Find the acceleration of P when $t = 2$ minutes.
 - (c) Find when P is moving perpendicular to the vector $\langle 1, 1 \rangle$.

6. The velocity vector of a moving particle P, at time t seconds, is given by, $\mathbf{v}(t) = \langle \frac{\pi}{2} \cos\left(\frac{\pi t}{2}\right), \frac{\pi}{2} \sin\left(\frac{\pi t}{2}\right) \rangle$ ms⁻¹.
 - (a) Find the displacement of P when $t = 4$ seconds, given that $\mathbf{r}(0) = \langle 0, 1 \rangle$.
 - (b) Find the acceleration of P when $t = 2$ seconds.
 - (c) Find when P is moving parallel to the vector $\langle 1, \sqrt{3} \rangle$.

7. The acceleration vector of a moving particle P, at time t , is given by, $\mathbf{a}(t) = \langle \sin t, \cos t \rangle$ cms⁻². $\mathbf{v}(0) = \langle -1, 0 \rangle$ and $\mathbf{r}(0) = \langle 0, 1 \rangle$.
 - (a) Find when the acceleration of P is parallel to $\langle 0, 1 \rangle$.
 - (b) Find when the acceleration of P is perpendicular to the vector $\langle \sqrt{3}, -1 \rangle$.
 - (c) Find the equation of the path of P. Give its direction.

8. The acceleration vector of a moving particle P at time t is given by, $\mathbf{a}(t) = \langle 4 \cos 2t, 4 \sin 2t \rangle$ ms⁻². $\mathbf{r}(0) = \langle -1, 0 \rangle$ m and $\mathbf{v}(0) = \langle 0, -2 \rangle$ ms⁻¹.
 - (a) Show that P experiences uniform circular motion. Give its direction.
 - (b) Find the velocity when the acceleration of P is parallel to $\langle -1, 1 \rangle$.
 - (c) Find when the acceleration of P is perpendicular to the vector $\langle -10, 10 \rangle$.

9. The position vector of particles P and Q at time t seconds are $\mathbf{r}(t) = \langle 2 \cos t, 2 \sin t \rangle$ and $\mathbf{r}(t) = \langle 1 + \cos t, 1 + \sin t \rangle$ respectively. Determine if P and Q will collide. If they do collide, state where and when this occurs.
10. The position vector of a moving particle P at time t is given by $\mathbf{r}(t) = \langle 3 \cos t, 2 \sin t \rangle$.
- Find the times when the velocity is perpendicular to the acceleration for $0 \leq t \leq 2\pi$.
 - Find an expression for the speed at time t , $|\mathbf{v}(t)|$.
 - Find the minimum and maximum speed of P and state where and when these speeds occur for $0 \leq t \leq 2\pi$.
 - Sketch the path of P indicating its direction and indicate when P is losing speed and picking up speed.
11. The position vector of a moving particle P at time t is given by $\mathbf{r}(t) = \langle 3 \cos t, -4 \sin t \rangle$.
- Find the period of motion for P.
 - Find the times when the velocity is perpendicular to the acceleration during the first cycle.
 - Calculate where and when P is furthest from the origin and state the velocities.
 - Calculate where and when P is closest to the origin and state the velocities.
12. Verify that a particle with position vector at time t given by $\mathbf{r}(t) = \langle 2 + 3 \cos t, 4 + 5 \sin t \rangle$ undergoes elliptical motion. State the period of the motion and the Cartesian equation of its path.
13. The velocity vector of a moving particle P, at time t seconds, is given by,
 $\mathbf{v}(t) = \langle 6\pi \sin 2\pi t, 8\pi \cos 2\pi t \rangle \text{ cms}^{-1}$.
- Find the distance from P to the origin when $t = 2$ seconds, given that $\mathbf{r}(0) = \langle -3, 0 \rangle$.
 - Find the acceleration of P when P has maximum speed.
 - Find when P is moving parallel to the vector $\langle 0, 10 \rangle$.
 - Find when P is moving perpendicular to the vector $\langle 8, 6 \rangle$.
14. The velocity vector of a moving particle P, at time t seconds, is given by,
 $\mathbf{v}(t) = -5\pi \sin(\pi t) \mathbf{i} - 12\pi \cos(\pi t) \mathbf{j} \text{ cms}^{-1}$.
- Find the distance from P to the origin when $t = 1/4$ seconds, given that $\mathbf{r}(0) = 5\mathbf{i}$.
 - Find the equation of the path of P given that $\mathbf{r}(0) = 5\mathbf{i}$ and give its direction.
 - Find when and where P is moving parallel to the vector $12\mathbf{j}$.
 - Find when P is moving perpendicular to the vector $12\sqrt{3}\mathbf{i} + 5\mathbf{j}$.
15. The acceleration vector of a moving particle P, at time t ,
 is $\mathbf{a}(t) = \langle -3 \sin t, -4 \cos t \rangle \text{ cms}^{-2}$. $\mathbf{r}(\pi/2) = \langle 3, 0 \rangle \text{ cm}$ and $\mathbf{v}(\pi/2) = \langle 0, -4 \rangle \text{ cms}^{-1}$.
- Find the maximum and minimum speed of P.
 - Find the velocity when the acceleration of P is perpendicular to its velocity vector.
 - Find when the acceleration of P is perpendicular to the vector $\langle 3, 0 \rangle$.

16. The acceleration vector of a moving particle P at time t is given by

$$\mathbf{a}(t) = \left\langle -\frac{3\pi^2}{4} \cos\left(\frac{\pi t}{2}\right), -\pi^2 \sin\left(\frac{\pi t}{2}\right) \right\rangle \text{ cms}^{-2}. \quad \mathbf{v}(0) = \langle 0, 2\pi \rangle \text{ cms}^{-1} \text{ and}$$

$$\mathbf{r}(0) = \langle 4, 2 \rangle \text{ cm.}$$

- Show that P experiences elliptical motion. State the Cartesian equation of its path and its direction of motion.
- Find the distance to the origin when the acceleration of P is perpendicular to its velocity.

17. The position vector of particles P and Q at time t seconds are $\mathbf{r}(t) = -3 \cos(t) \mathbf{i} + 4 \sin(t) \mathbf{j}$ and $\mathbf{r}(t) = [-4 + 2 \cos(t)] \mathbf{i} + [3 - \sin(t)] \mathbf{j}$ respectively. Determine when and where P and Q collide and the velocity of P and Q at the time of collision.

18. The position vector of particles P and Q at time t seconds are

$$\mathbf{r}(t) = [1 + 4 \sin(t)] \mathbf{i} + [1 + 3 \cos(t)] \mathbf{j} \text{ and } \mathbf{r}(t) = [1 - \sin(t)] \mathbf{i} + [-1 + \cos(t)] \mathbf{j}$$

respectively. Determine when and where P and Q collide and the angle between the velocity vectors of P and Q at the time of collision.

18.3.2 Projectile Motion

- In this section we consider the motion of a particle moving in a vertical plane under the influence of gravity. The only force acting on the particle is gravity with air resistance being ignored.
- Consider a particle P projected from the point $\mathbf{r} = \langle a, b \rangle \text{ m}$ with velocity $\mathbf{v} = \langle p, q \rangle \text{ ms}^{-1}$. As gravity is the only force acting on P, the acceleration $\mathbf{a}(t) = \langle 0, -g \rangle \text{ ms}^{-2}$ where g is the acceleration due to gravity.

- Integrate $\mathbf{a}(t)$: $\mathbf{v}(t) = \langle p, -gt + q \rangle$ since $\mathbf{v}(0) = \langle p, q \rangle$.

- Integrate $\mathbf{v}(t)$: $\mathbf{r}(t) = \langle pt + a, -\frac{gt^2}{2} + qt + b \rangle$ since $\mathbf{r}(0) = \langle a, b \rangle$.

- Parametric equation of path: $x = pt + a \quad y = -\frac{gt^2}{2} + qt + b$

Substitute $t = \frac{x-a}{p}$ into y : $y = -\frac{g}{2} \left(\frac{x-a}{p} \right)^2 + q \left(\frac{x-a}{p} \right) + b$

- Clearly the Cartesian equation is that of a parabola. Therefore, the path traced by a projectile moving solely under the influence of gravity is parabolic in shape.

- Consider a particle P projected from the origin with speed v at an angle of θ with the x -axis. The acceleration $\mathbf{a}(t) = \langle 0, -g \rangle \text{ ms}^{-2}$ where g is the acceleration due to gravity.

- Velocity of projection in component form:

$$\mathbf{v}(0) = \langle v \cos \theta, v \sin \theta \rangle.$$

- Integrate $\mathbf{a}(t)$: $\mathbf{v}(t) = \langle v \cos \theta, -gt + v \sin \theta \rangle.$

- Integrate $\mathbf{v}(t)$: $\mathbf{r}(t) = \langle v \cos \theta t, -\frac{gt^2}{2} + v \sin \theta t \rangle.$

- Parametric equation of path:

$$x = v \cos \theta t \quad y = -\frac{gt^2}{2} + v \sin \theta t$$

Substitute $t = \frac{x}{v \cos \theta}$ into y :

$$\begin{aligned} y &= -\frac{g}{2} \left(\frac{x}{v \cos \theta} \right)^2 + v \sin \theta \left(\frac{x}{v \cos \theta} \right) \\ &= \left(-\frac{g \sec^2 \theta}{2v^2} \right) x^2 + \tan \theta x. \end{aligned}$$

- Hence, the Cartesian equation of particle projected with a speed of v at an angle θ to the origin is

$$y = \left(-\frac{g \sec^2 \theta}{2v^2} \right) x^2 + \tan \theta x.$$

Example 18.7

A particle P is projected from the origin with a speed of 20 ms^{-1} at an angle of 60° to the horizontal. Assume that the only force acting on P is the gravitational force and that the acceleration due to gravity is 9.8 ms^{-2} . Find an expression for $\mathbf{v}(t)$ the velocity vector of P t seconds after projection.

Solution:

Velocity of projection in component form: $\langle 20 \cos 60, 20 \sin 60 \rangle = \langle 10, 10\sqrt{3} \rangle.$

As P experiences no horizontal acceleration its horizontal velocity remains unchanged.

P experiences a vertical acceleration of -9.8 ms^{-2} ,

hence its vertical velocity changes by -9.8 ms^{-1} every second.

Therefore: $\mathbf{v}(t) = \langle 10, 10\sqrt{3} - 9.8t \rangle$

Alternative Solution:

Integrate $\mathbf{a}(t) = \langle 0, -9.8 \rangle. \Rightarrow \mathbf{v}(t) = \langle 10, -9.8t + 10\sqrt{3} \rangle$ as $\mathbf{v}(0) = \langle 10, 10\sqrt{3} \rangle.$

Example 18.8

A particle P is projected from the origin with a speed of 60 ms^{-1} at an angle of 30° to the horizontal. Assume that the only force acting on P is the gravitational force and that the acceleration due to gravity is 9.8 ms^{-2} .

- Find an expression for the position vector of P t seconds after projection.
- Find the time taken for P to reach its maximum height and hence find the time of flight.
- Find the range for P.
- Find the Cartesian equation of the path of P.

Solution:

- (a) Initial velocity in component form: $\mathbf{v}(0) = \langle 60 \cos 30, 60 \sin 30 \rangle = \langle 60\sqrt{3}, 30 \rangle$.

Hence: $\mathbf{v}(t) = \langle 30\sqrt{3}, 30 - 9.8t \rangle$

Integrate: $\mathbf{r}(t) = \langle 30\sqrt{3}t, 30t - 4.9t^2 \rangle$ since $\mathbf{r}(0) = \langle 0, 0 \rangle$.

- (b) When P achieves maximum height, the vertical component of $\mathbf{v}(t)$ is zero.

Hence $30 - 9.8t = 0$

Thus $t = 3.06$ seconds

As the path is parabolic, it is symmetrical about the axis of symmetry.

Hence, the time taken for P to hit the ground again, T, is twice the time taken to reach the maximum height.

Therefore $T = 6.12$ seconds.

- (c) P hits the ground again after 6.12 seconds.

Substitute $t = 6.12$ into the horizontal component $\mathbf{r}(t)$:

$$r_x = (30\sqrt{3})(6.12) \approx 318 \text{ metres}$$

- (d) The parametric equation of the path is given by:

$$x = 30\sqrt{3}t \quad y = 30t - 4.9t^2$$

Rearranging: $t = \frac{x}{30\sqrt{3}}$

Substitute into y : $y = 30\left(\frac{x}{30\sqrt{3}}\right) - 4.9\left(\frac{x}{30\sqrt{3}}\right)^2$

Hence, the equation of the path is $y = 0.577x - 0.0018x^2$

Notes:

- The time of flight is the time the body is in the air. That is, the time interval between projection and the body hitting the ground.
- The range is the horizontal distance covered between projection and the body hitting the ground.

Exercise 18.4

For Questions 1 to 12, assume that the only force acting on the moving bodies is the gravitational force and that the acceleration due to gravity is 9.8 ms^{-2} .

- A particle P is projected from the origin with a velocity of $\langle 30, 30\sqrt{3} \rangle \text{ ms}^{-1}$.

 - Find the velocity $\mathbf{v}(t)$ of P at any time t and find the direction of P when $t = 5$ sec.
 - Find the angle between $\mathbf{a}(5)$ and $\mathbf{v}(5)$.
 - Find the time of flight and range of P.
- A particle P is projected from the origin with a speed of 50 ms^{-1} at an angle of 45° to the x -axis.

 - Find $\mathbf{r}(3)$, the position vector of P at time $t = 3$ seconds.
 - Find the angle between $\mathbf{r}(3)$ and $\mathbf{v}(3)$ where $\mathbf{v}(3)$ is the velocity of P at $t = 3$ seconds.
 - Find when P is at a height of 50m.
 - Find the Cartesian equation for the path of P.
- A particle P is projected from the origin O with a velocity of $\langle 20, 20 \rangle \text{ ms}^{-1}$.

 - Find $\mathbf{r}(t)$, the position vector of P at time t .
 - Find the angle of impact between P and the ground.
 - Determine where and when P is travelling at an angle of 30° to the x -axis.
 - Find the total distance travelled by P (from projection to the time it hits the ground).
- A particle P is projected from the edge of a 150 m high building with a velocity of $\langle 25\sqrt{3}, 25 \rangle \text{ ms}^{-1}$. Take the foot of the building as the origin of the x - y axes.

 - Find the velocity vector and position vector of P at time t .
 - Find the time P takes to hit the ground.
 - Find the angle with which P hits the ground.
 - Find the horizontal distance from the base of the building where P hits the ground.
- A particle P is projected *horizontally* from the edge of a 100m cliff with a speed of 50 ms^{-1} . Take the base of the cliff O, as the origin of the x - y axes.

 - Find an expression for the velocity vector and position vector of P at time t .
 - Find the time P takes to hit the ground.
 - Find the maximum horizontal distance reached by P (measured from the cliff).
 - Find the angle with which P hits the ground.
- A boy throws a ball from ground level towards a large flat roof a building. The near edge of the roof R is at a horizontal distance of 7.5 m from the boy and the roof is 4m above ground level. The ball passes vertically above R 1.5 seconds after being thrown. The velocity vector t seconds after projection is given by $\mathbf{v}(t) = \langle \frac{5v}{13}, \frac{12v}{13} - 9.8t \rangle$, where v is a constant. Take the point of projection as the origin.

 - Find the speed of projection.
 - Find the height clearance of the stone as it passes over R.
 - Find the distance from R of the point where the stone hits the roof.
 - Find the magnitude and direction of the stone's velocity when it hits the roof.

7. A particle P is projected from the point A at the foot of a plane inclined at an angle of 30° to the horizontal. The velocity vector of P is given by $\mathbf{v}(t) = 30\mathbf{i} + (30\sqrt{3} - 9.8t)\mathbf{j}$, where t is time in seconds after P is projected. P hits the inclined plane at B. The position vector of point B (with point A as the origin) is $p\mathbf{i} + q\mathbf{j}$.
- Find expressions for p and q in terms of t_0 the time taken for P to hit B.
 - Find the time taken for P to travel from A to B.
 - How far up the hill is point B?
8. The position vector of a particle P, at time t seconds, is given by $\mathbf{r}(t) = \langle 20t \cos 20^\circ, 20t \sin 20^\circ - 4.9t^2 \rangle$ m.
- Find the equation of the path of P and show that the path is parabolic.
 - Find the distance of P from the point of projection when $t = 1$ second.
 - Find the distance travelled by the ball along its path in the first second.
 - Find when P is moving parallel to $\langle \cos 20^\circ, \sin 20^\circ \rangle$.
9. The particle P is projected from the origin with a speed of 10 ms^{-1} at an angle of 36° to the x -axis.
- Find the change in displacement between $t = 2$ seconds and $t = 3$ seconds.
 - Find the distance between its position at $t = 2$ and $t = 3$ seconds.
 - Find the distance travelled along its path between $t = 2$ seconds and $t = 3$ seconds.
 - Find the change in the direction of motion between $t = 2$ seconds and $t = 3$ seconds.
10. Two particles P and Q are simultaneously projected under gravity from the points O and A respectively where OA is a horizontal line of length 200m and the point A is to the right of O. Take O as the origin of the x - y axes. The position vector of P, t seconds after projection is given by $\mathbf{r}(t) = 18t\mathbf{i} + (24t - 4.9t^2)\mathbf{j}$. The velocity of Q, t seconds after projection is given by $\mathbf{v}(t) = -32\mathbf{i} + (24 - 9.8t)\mathbf{j}$.
- Find when P and Q collide.
 - Find the position vector of the point of collision.
11. A particle P is projected from the origin with initial velocity $\mathbf{v}(t) = 28\mathbf{i} + (100 - 9.8t)\mathbf{j}$ towards an inclined plane whose line of greatest slope has equation $\mathbf{r} = 480\mathbf{i} + \lambda(2\mathbf{i} + \mathbf{j})$, where λ is a parameter. Find the time taken for the particle to strike the plane. Determine the distance along the line of greatest slope from the point where $\lambda = 0$ to the point of impact.
12. A missile is fired at a target from the origin O, with the velocity vector t seconds after it was fired, given by $\mathbf{v}(t) = u \cos(\theta)\mathbf{i} + [u \sin(\theta) - gt]\mathbf{j}$, where u , θ and g are constants. The target is moving with velocity $v\mathbf{i}$ and at the instant the missile is fired the target is at position $h\mathbf{j}$.
- Prove that for the missile to hit the target $u^2 \geq v^2 + 2gh$.
 - If this condition is fulfilled, and the missile does hit the target and has velocity $0.3u\mathbf{i} + 4u\mathbf{j}$ immediately before collision, find the value of $\cos(\theta)$.

Questions 13 to 15 include the presence of forces other than gravity.

13. The position vector at time t of a particle P is given by $\mathbf{r}(t) = (t^3 - 2t)\mathbf{i} + t^2\mathbf{j}$, $t \geq 0$.
- Obtain an expression for the velocity of P at time t .
 - Obtain an expression for the acceleration of P at time t .
 - Find the two values of t for which the acceleration and the velocity of P are perpendicular.
14. The position vector of a moving particle at time t , is given by $\mathbf{r}(t) = (5 + 20t)\mathbf{i} + (95 + 10t - 5t^2)\mathbf{j}$.
- Find the initial velocity of P.
 - Find the time T when P is moving at right angles to its initial direction of motion.
 - Find the distance of P from its initial position at time T.
15. An object P has an initial velocity of $\langle 10, 20 \rangle \text{ ms}^{-1}$. P experiences a constant acceleration of $\langle -1, -10 \rangle \text{ ms}^{-2}$. Its initial displacement $\mathbf{r}(0) = \mathbf{0}$. Find:
- the direction of P at time $t = 1$ second
 - the distance between P at time $t = 2$ seconds and its initial position
 - the maximum height reached by P and the corresponding value of t
 - the point where P hits the ground and the corresponding value of t .
16. A particle P has an initial velocity of $5\mathbf{i} + 15\mathbf{j} \text{ ms}^{-1}$. Its initial displacement vector $\mathbf{r}(0) = \mathbf{0}$. The acceleration of P is $2\mathbf{i} - 10\mathbf{j} \text{ ms}^{-2}$. Find:
- the horizontal distance travelled by P in the first 2 seconds
 - the change in displacement of P in the first 2 seconds
 - the distance between P at time $t = 2$ seconds and its initial position
 - the distance travelled by P along its path in the first 2 seconds.

19 The Central Limit Theorem

19.1 Sampling Distributions

- The table below shows the heights (in cm) of eight samples of ten adults each and the mean height of the adults in each sample. These samples are taken from a larger set called the population or a parent set.

Sample	1	2	3	4	5	6	7	8
	175	157	186	191	186	180	173	166
	173	187	191	161	170	156	169	189
	175	165	177	154	196	194	170	179
	150	190	166	167	200	188	161	162
	177	168	176	192	176	168	187	152
	151	193	198	196	173	168	157	177
	187	151	190	174	174	172	185	200
	156	193	184	171	200	154	190	186
	176	179	198	172	169	199	191	187
	176	154	195	173	168	182	172	165
Mean	169.6	173.7	186.1	175.1	181.2	176.1	175.5	176.3

- It can clearly be seen that the sample means, 169.6, 173.7, 186.1, 175.1, 181.2, 176.1, 175.5 and 176.3 cm are all different and form a distribution of their own.
- The distribution formed by the means of *all* possible samples of size 10 from this population is called the *sampling distribution of sample means of sample size 10*. There are different sampling distributions of the sample means for samples of different sizes.
 - The set of eight sample means above form a frequency distribution of sample means of sample size 10. As the number of samples obtained increases, the frequency distribution approaches the sampling distribution of sample means of sample size 10.
- It can be shown that if the samples of size n are taken from a population with mean μ and standard deviation σ , then the sampling distribution of the sample means of sample size n will have a mean of μ and standard deviation $\frac{\sigma}{\sqrt{n}}$.
 - Note that the standard deviation of the sampling distribution depends on the size of the sample and *not* on the number of samples taken.
- If the parent (population) distribution is normal, then the sampling distribution of sample means will also be normal.
 - For example, if samples of size 20 are taken from a population with a normal distribution with mean 175 cm and standard deviation 12.2 cm, then the distribution formed by the sample means will also be normally distributed but with mean 175 cm and standard deviation $\frac{12.2}{\sqrt{20}}$ cm.

Example 19.1

The mean weight of year 12 students in a certain state is known to be normally distributed with mean 65.2 kg with standard deviation 4.7 kg. Samples of size 25 each are taken and the mean weight of each sample calculated.

- Find the mean weight and standard deviation of the distribution of the sample means.
- Find the probability that the mean weight of a randomly chosen sample is less than 66 kg.
- Of 300 samples taken (each of size 25), how many of these samples would have mean weights that exceed 65 kg?

Solution:

- (a) Mean weight of sample means = 65.2 kg

$$\text{Standard deviation of the sample means} = \frac{4.7}{\sqrt{25}} = 0.94 \text{ kg}$$

- (b) Let \bar{X} : sample mean

Since the parent population is normally distributed, $\bar{X} \sim N(65.2, 0.94^2)$.

Hence, $P(\bar{X} < 66) = 0.8026$.

- (c) $P(\bar{X} > 65) = 0.5842$.

Hence, expected number = $300 \times 0.5842 = 175.3 \approx 175$.

Example 19.2

X is a binomial variable with $n = 10$ and $p = \frac{2}{5}$. A sample of 20 observations on X is taken

and the mean of the sample \bar{X} calculated.

- Find the mean and standard deviation for X.
- Find the mean and standard deviation for \bar{X} .

Solution:

- (a) Mean for X = $10 \times \frac{2}{5} = 4$

$$\text{Standard deviation} = \sqrt{10 \times \frac{2}{5} \times \frac{3}{5}} = \frac{2\sqrt{15}}{5}$$

- (b) Mean for $\bar{X} = 4$

and standard deviation for $\bar{X} = \frac{\left(\frac{2\sqrt{15}}{5}\right)}{\sqrt{20}} = \frac{\sqrt{3}}{5}$.

Exercise 19.1

1. The random variable X is normally distributed with mean 100 and standard deviation 12. Samples of 20 observations of X are taken and the mean of each of the samples \bar{X} calculated.
 - (a) Find the probability distribution for \bar{X} .
 - (b) Find $P(X > 105)$ (c) Find $P(\bar{X} > 105)$.

2. The normal variable X has mean 72 and standard deviation 8. Samples of 50 observations of X are taken and the mean of each of the samples \bar{X} calculated.
 - (a) Find the probability distribution for \bar{X} .
 - (b) Find $P(70 \leq X \leq 72)$ (c) Find $P(70 \leq \bar{X} \leq 72)$.

3. The normal variable X has mean 750 and standard deviation 25. Samples of n observations of X are taken and the mean of each of the samples \bar{X} calculated.
 - (a) Find n if the standard deviation for \bar{X} is to be 2.9.
 - (b) Find n if the standard deviation for \bar{X} is to be between 2.8 and 3.0.

4. The random variable X is normally distributed with mean 2.5 and standard deviation 0.05. Samples of n observations of X are taken and the mean of each of the samples \bar{X} calculated.
 - (a) Find n if the standard deviation for \bar{X} is to be 0.01.
 - (b) Find n if the standard deviation for \bar{X} is to be between 0.005 and 0.01.

5. The random variable X is uniformly distributed with variance 3 in the interval $0 \leq x \leq 6$. Samples of n observations of X are taken and \bar{X} the mean value of X calculated.
 - (a) Find the mean for X .
 - (b) For $n = 49$, find the mean and standard deviation for \bar{X} .
 - (c) Find n if the standard deviation for \bar{X} is to be between 0.5 and 1.0.

6. The uniform variable X is distributed in the interval $0 \leq x \leq 36$ with variance 108. Samples of n observations of X are taken and \bar{X} the mean value of X calculated.
 - (a) Find the mean for X .
 - (b) For $n = 81$, find the mean and standard deviation for \bar{X} .
 - (c) Find n if the standard deviation for \bar{X} is to be between 1.0 and 1.5.

7. The mass of a certain species of adult wallabies is known to be normally distributed with mean 1.7 kg with standard deviation 0.13 kg. Samples, each consisting of 25 adult wallabies of this species are weighed.
 - (a) Describe with reasons the probability distribution for the mean mass of the samples.
 - (b) Find the probability that a randomly chosen adult wallaby of this species has mass less than 1.75 kg.
 - (c) Find the probability that a randomly chosen sample of 25 adult wallabies of this species has a mean mass of less than 1.75 kg.

8. The length of a certain species of adult salmon is known to be normally distributed with mean 875 mm and standard deviation 11.7 mm.
- Describe with reasons the probability distribution for the mean length of samples of 20 adult salmon of this species.
 - Find the probability that a randomly chosen adult salmon of this species measures at least 880 mm long.
 - Find the probability that a randomly chosen sample of 20 adult salmon of this species has a mean length of at least 880 mm.
 - What should the size of the sample be, if the standard deviation of the sampling distribution of sample means is to be no more than 1.5 mm?
9. The sampling distribution of the mean heights of samples of 60 eighteen year old males has mean 175 cm with a standard error of 1.1 cm. Assume that the heights of eighteen year old males are normally distributed.
- Find with reasons, the mean heights of all eighteen year old males and its associated standard deviation.
 - Find the required sample size if the standard deviation of the sampling distribution of the sample means is to be 0.9 cm.
 - Of 200 samples, each with 25 eighteen year old males, how many of these samples would have mean heights that exceed 178 cm.
 - Of 5000 eighteen year old males selected, how many of these would have heights that exceed 178 cm.
10. The sampling distribution of the mean heights of samples of 80 eighteen year old females has mean 163 cm with a standard error of 1.1 cm. Assume that the heights of eighteen year old females are normally distributed.
- Find with reasons, the mean heights of all eighteen year old females and its associated standard deviation.
 - Find the required sample size if the standard deviation of the sampling distribution of the sample means is to be 1.2 cm.
 - Of 100 samples, each with 20 eighteen year old females, how many of these samples would have mean heights that are between 162 and 164 cm.
 - Of 2000 eighteen year old females selected, how many of these would have heights between 162 and 164 cm.
11. X is a binomial variable with $n = 50$ and $p = \frac{3}{10}$. A sample of k observations on X is taken and the mean of the sample \bar{X} calculated.
- For $k = 25$, find the mean and standard deviation for X and \bar{X} .
 - Find k if the standard deviation for \bar{X} is to be between 1.0 and 1.5.
12. X is a binomial variable with $n = 100$ and $p = 0.95$. A sample of k observations on X is taken and the mean of the sample \bar{X} calculated.
- For $k = 36$, find the mean and standard deviation for X and \bar{X} .
 - Find k if the standard deviation for \bar{X} is to be between 0.5 and 1.5.

13. It is known that 5% of biro's are defective. These biro's are sold in packs of 12.
- Find the mean number of defective biro's in a randomly chosen pack, stating its accompanying standard deviation.
 - Find the mean and standard deviation for the sampling distribution of the mean number of defective biro's per pack.
14. An eight sided die (with faces numbered 1 to 8) is rolled 36 times. Define X : No. obtained on one roll of the die. Define \bar{X} : the mean of the 36 numbers obtained.
- Find the probability distribution for X stating its mean and standard deviation.
 - Find the mean and standard deviation for \bar{X} .
15. A six sided die (with faces numbered 1 to 6) is rolled n times. Define X : No. obtained on one roll of the die. Define \bar{X} : the mean of the n numbers obtained.
- Find the probability distribution for X stating its mean and standard deviation.
 - For $n = 16$, find the mean and standard deviation for \bar{X} .
 - Find n if the standard deviation for \bar{X} is to be between 0.1 and 0.4.

19.2 The Central Limit Theorem

- Previously, it was pointed out that the sampling distribution of sample means of sample size n :
 - has mean = population mean μ
 - has standard deviation = $\frac{\text{population standard deviation}}{\sqrt{\text{size of sample}}} = \frac{\sigma}{\sqrt{n}}$
- The Central Limit Theorem states that the sampling distribution of sample means has a distribution that approaches the *normal* distribution as the sample size n increases.
 - That is, as the sample size n increases, the sampling distribution of sample means of sample size n tends towards a normal distribution with mean = μ and standard deviation = $\frac{\sigma}{\sqrt{n}}$.
- For practical purposes, it is acceptable to treat the sampling distribution as normally distributed as long as the size of the sample $n \geq 30$.
 - Therefore, if $n \geq 30$, $\bar{X} \sim N\left(\mu, \left(\frac{\sigma}{\sqrt{n}}\right)^2\right)$.
- That is, irrespective of the probability distribution possessed by the parent distribution, the sampling distribution of sample means becomes increasingly normal as the size of the samples increases.
 - For example, if the size of the sample n is large and if the parent distribution is uniform or binomial, the sampling distribution of the sample means of sample size n will be approximately normal.

- The table below summarises the implications of the Central Limit Theorem.

Parent Distribution		Sampling Distribution for Sample Means	
		Sample size $n < 30$	Sample size $n \geq 30$
Type	Normal	Normal	Normal
Mean	μ	μ	μ
Standard Deviation	σ	$\frac{\sigma}{\sqrt{n}}$	$\frac{\sigma}{\sqrt{n}}$
Type	Non-Normal		Approximate Normal
Mean	μ	μ	μ
Standard Deviation	σ	$\frac{\sigma}{\sqrt{n}}$	$\frac{\sigma}{\sqrt{n}}$

Example 19.3

A continuous random variable X has mean 50 and standard deviation 6.1. Samples of 100 observations each are taken of X and \bar{X} the means for each sample calculated. State the probability distribution for \bar{X} .

Solution:

As the size of the sample = 100 > 30, by the Central Limit Theorem, \bar{X} is approximately normally distributed

with mean = 50 and standard deviation = $\frac{6.1}{\sqrt{100}} = 0.61$.

Example 19.4

The amount of soft-drink dispensed by an automatic dispenser is uniformly distributed with mean 300 ml and standard deviation $\frac{10\sqrt{3}}{3}$ ml. Several samples of 50 cups each were examined and the mean of each sample calculated.

- Describe the probability distribution that best models this distribution of sample means.
- Find the probability that a randomly chosen sample has a mean no less than 299 ml given that its mean is no more than 301 ml.

Solution:

- (a) The sample size $n = 50 > 30$.
Hence, by the Central Limit Theorem,
the sample means will be approximately normally distributed.

Mean for sampling distribution = 300 ml.

$$\text{Standard deviation of sampling distribution} = \frac{10\sqrt{3}}{\sqrt{50}} = \frac{\sqrt{6}}{3} \text{ ml.}$$

- (b) Let \bar{X} : sample mean

$$\begin{aligned} P(\bar{X} \geq 299 \mid \bar{X} \leq 301) &= \frac{P(299 \leq \bar{X} \leq 301)}{P(\bar{X} \leq 301)} \\ &= \frac{0.77933}{0.88966} \\ &= 0.8760 \end{aligned}$$

A calculator screen showing the following steps and results:

normCdf(299, 301, $\frac{\sqrt{6}}{3}$, 300)	0.77933
normCdf(-∞, 301, $\frac{\sqrt{6}}{3}$, 300)	0.88966
0.77933/0.88966	0.87599

Note:

- The parent population has a uniform distribution. As its sample size exceeds 30, the distribution of sample means has an approximate normal distribution

Example 19.5

A radioactive substance emits particles randomly. The mean time interval between successive emissions is 90 seconds with a variance of 90. Assume that the particles are emitted independently and no two particles are emitted at the same time. In a study conducted, one hundred samples of 60 successive emissions times were recorded.

Define \bar{T} : the mean time interval between successive emissions for each sample.

- (a) Describe the probability distribution for \bar{T} .
(b) Estimate the probability that the time taken to record 60 successive emissions exceeds 92 minutes.

Solution:

- (a) By the Central Limit Theorem, as the sample size is 60 (> 30),

$$\bar{T} \text{ is approximately normally distributed with mean} = 90 \text{ and variance} = \frac{90}{60} = \frac{3}{2}.$$

- (b) Mean time interval between successive emissions for sample = $\frac{92 \times 60}{60} = 92$ seconds.

$$\text{Hence, } P(\bar{T} > 92) = 0.05124$$

Note:

- As in the previous example, the parent population is not normally distributed. In fact it has an unknown distribution but the distribution of sample means has an approximate normal distribution as its sample size exceeds 30.

Example 19.6

A box has 8 green balls and 2 red balls. 5 balls are drawn with replacement from this box and the number of green balls noted. This procedure is repeated 40 times to form a sample of 40 observations. If we define X : No. of green balls drawn, then we have a sample of 40 observations on X . The mean number of green balls in this sample of 40 is calculated and denoted \bar{X} . Other samples of 40 observations on X are formed and \bar{X} is calculated for each sample to form a sampling distribution for \bar{X} .

- Find the probability distribution for X stating its mean and standard deviation.
- State the probability distribution for \bar{X} .
- Find the probability that for any randomly chosen sample of 40 observations of X , \bar{X} is between 3.8 and 4.

Solution:

- Since the balls are drawn with replacement,

$$P(\text{Green Ball}) = \frac{8}{10} = \frac{4}{5} \text{ which is constant for each draw.}$$

$$\text{Hence } X \sim B(n = 5, p = \frac{4}{5}).$$

$$\text{Mean number of green balls in a draw of 5 balls} = 5 \times \frac{4}{5} = 4.$$

$$\text{Variance for the number of green balls in a draw of 5 balls} = 5 \times \frac{4}{5} \times \frac{1}{5} = \frac{4}{5}.$$

$$\text{Hence, standard deviation} = \frac{2}{\sqrt{5}} = \frac{2\sqrt{5}}{5}.$$

$$\text{That is, mean for } X \text{ is 4 and standard deviation is } \frac{2\sqrt{5}}{5}.$$

- The sample size of 40 observations on X exceeds 30.
Hence, by the Central Limit Theorem, \bar{X} is approximately normally distributed.

$$\text{Mean for sampling distribution for } \bar{X} = 4.$$

$$\text{Standard deviation for sampling distribution for } \bar{X} = \frac{\frac{2\sqrt{5}}{5}}{\sqrt{40}} = \frac{\sqrt{2}}{10}.$$

- $\bar{X} \sim N(4, \frac{2}{100})$

$$\text{Hence, } P(3.8 \leq \bar{X} \leq 4) = 0.4214.$$

The image shows a calculator screen with the following text: normCDF(3.8, 4, $\frac{\sqrt{2}}{10}$, 4) and the result 0.4213503965.

Note:

- The parent distribution for X is a binomial distribution which is a discrete distribution. But the distribution for \bar{X} is an approximate normal distribution, which is a continuous distribution. These few examples demonstrate why the Central Limit Theorem is unofficially recognised as the most important theorem in statistical and probability theory.

Example 19.7

The amount of mango juice in packs sold by Joy Juice Co. has mean 999.9 ml and standard deviation 1.1 ml.

- (a) Find the probability that a randomly selected sample of 100 packs of mango juice has mean contents of less than 1000 ml. .
- (b) Determine the size n of a random sample of packs of mango juice if the standard deviation of the sampling distribution of the sample means is to be 0.05 ml.

Solution:

- (a) Let \bar{X} : Mean of sample

Since size of sample = 100 (> 30), \bar{X} is approximately normal

with mean = 999.9 and standard deviation $\frac{1.1}{\sqrt{100}} = 0.11$.

Hence, $P(\bar{X} < 1000) = 0.8183$.

- (b) Let size of sample be n .

Standard deviation for $\bar{X} = \frac{1.1}{\sqrt{n}} = 0.05 \Rightarrow n = 484$.

Exercise 19.2

1. The continuous random variable X has mean 200 and standard deviation 35. Samples of 60 observations of X are taken and the mean of each of the samples \bar{X} calculated.
 - (a) Find the probability distribution for \bar{X} . (b) Find $P(\bar{X} \leq 210)$.
2. The continuous random variable X has mean 4.5 and standard deviation 1.2. Samples of 80 observations of X are taken and the mean of each of the samples \bar{X} calculated.
 - (a) Find the probability distribution for \bar{X} . (b) Find $P(4.4 \leq \bar{X} \leq 4.6)$.
3. The variable X is uniformly distributed for $0 \leq x \leq 24$ with standard deviation $4\sqrt{3}$. Samples of 36 observations of X are taken and the mean of each of the samples \bar{X} calculated.
 - (a) Find the probability distribution for \bar{X} .
 - (b) Find $P(11 \leq X \leq 13)$ (c) Find $P(11 \leq \bar{X} \leq 13)$.
4. The variable X is uniformly distributed for $10 \leq x \leq 46$ with standard deviation $6\sqrt{3}$. Samples of n observations of X are taken and the mean of each of the samples \bar{X} calculated.
 - (a) For $n = 49$, find the probability distribution for \bar{X} .
 - (b) For $n = 49$, find: (i) $P(28 \leq X \leq 30)$ (ii) Find $P(28 \leq \bar{X} \leq 30)$.
 - (c) Find n if the standard deviation for \bar{X} is not to exceed 1.15.

5. The waiting time at a doctor's surgery is uniformly distributed over the interval 5 to 19 minutes with variance $\frac{49}{3}$. In a study conducted by the surgery, the waiting times of 10 samples of 30 patients each, were recorded.
- Find the mean waiting time of all patients at this surgery.
 - Describe the probability distribution that best models the distribution of the means of the sample waiting times.
 - Find the probability that a randomly chosen:
 - patient has to wait at least 13 minutes.
 - sample has a mean waiting time of at least 13 minutes.
 - Find the probability that exactly two samples each have mean waiting times of at least 13 minutes.
6. The amount of sugar dispensed by an automatic sugar dispenser is uniformly distributed with mean 2 g and standard deviation $\frac{\sqrt{3}}{15}$ g. The dispenser was used n times and the mean amount of sugar for the sample calculated. This exercise was repeated 20 times.
- Describe the probability distribution that best models the distribution of the sample means.
 - For (i) $n = 30$, (ii) $n = 100$; find the probability that a randomly chosen sample has a mean not exceeding 2.01 g. Comment on your answers.
 - Find n so that the standard error is no more than 0.01 g.
 - Estimate the probability that when the dispenser is used 40 times, the total amount of sugar dispensed does not exceed 81 g.
7. The amount of cooking salt dispensed by an automatic salt dispenser is uniformly distributed with mean 3 g and standard deviation $\frac{\sqrt{3}}{30}$ g.
- Estimate the probability that when the dispenser is used:
 - 30 times, the total amount of salt dispensed exceeds 89.7 g.
 - 100 times, the total amount of salt dispensed exceeds 299 g.
 - When the dispenser is used n times, the standard deviation associated with the mean amount of salt dispensed per occasion is $\frac{\sqrt{5}}{600}$. Find n .
8. A radioactive substance emits particles randomly. The mean time interval between successive emissions is 150 seconds with a variance of 150. Assume that the particles are emitted independently and no two particles are emitted at the same time.
- Estimate the probability that:
 - the time taken to record 50 successive emissions exceeds 124 minutes
 - no more than 252 minutes is required to record 100 successive emissions.
 - The probability that the time taken to record 50 successive emissions will exceed k minutes is approximately 0.05. Find k .

9. The time interval between successive customers conducting transactions through an automatic teller machine (ATM) has mean 2 minutes with variance 2. The ATM log records the number of customers accessing the machine.
- (a) Estimate the probability that:
- the time taken to record 40 successive customers exceeds 82 minutes
 - no more than 199 minutes is required to record 100 successive customers.
- (b) The probability that the time taken to record 50 successive emissions does not exceed k minutes is approximately 0.1. Find k .
10. The discrete random variable X has mean 0.15 and variance 1.275. Samples of 50 observations of X are taken and \bar{X} the mean of each of the samples calculated.
- (a) Find the probability distribution for \bar{X} (b) Find $P(\bar{X} < 0.18 \mid \bar{X} > 0.15)$
- (c) Of 50 samples, each with 50 observations of X , how many are expected to have sample means less than 0.18.
11. The random variable X has probability density function $P(X = x) = \frac{1}{10}$ for $x = 1, 2, \dots, 9, 10$. The standard deviation for X is $\frac{\sqrt{33}}{2}$. Samples of 50 observations of X are taken and \bar{X} the mean of each of the samples calculated.
- (a) Find the probability distribution for \bar{X} .
- (b) Find: (i) $P(4 \leq X \leq 6)$ (ii) $P(4 \leq \bar{X} \leq 6)$
- (c) Of 100 samples, each with 50 observations of X , how many are expected to have sample means between 4 and 6 inclusive.
12. The binomial variable X has parameters $n = 20, p = 0.35$. Samples of 50 observations of X are taken and \bar{X} the mean of each of the samples calculated.
- (a) Find the probability distribution for \bar{X} .
- (b) Find: (i) $P(6 \leq X \leq 7)$ (ii) $P(6 \leq \bar{X} \leq 7)$.
- (c) Of 100 samples of 50 observations of X each, how many would have sample means between 6 and 7 inclusive.
13. An eight sided die (with faces numbered 1 to 8) is rolled 36 times.
- Define X : No. obtained on one roll of the die. The standard deviation for $X = \frac{\sqrt{21}}{2}$.
- Define \bar{X} : the mean of the 36 numbers obtained.
- (a) Find the probability distribution for X .
- (b) Find the probability distribution for \bar{X} .
- (c) Find the probability that for any randomly chosen sample of 36 rolls of the die, the mean of the sample is between 2 and 5 inclusive.
- (d) Find the probability that in 20 sets of 36 rolls of the die, at least 18 sets would have sample means of between 2 and 5 inclusive.

14. A six sided die (with faces numbered 1 to 6) is rolled n times.

Define X : No. obtained on one roll of the die. The standard deviation for $X = \frac{\sqrt{105}}{6}$.

Define \bar{X} : the mean of the n numbers obtained.

- Find the probability distribution for X stating its mean.
- For $n = 49$, state the probability distribution for \bar{X} .
- Find the probability that for any randomly chosen sample of 49 rolls of the die, the mean of the sample is between 1 and 3.
- Find n so that the standard deviation for \bar{X} is no more than 0.5.

15. It is known that 10% of biros sold by a Two Dollar Shop are defective. These biros are sold in packs of 50.

- Find the mean number of defective biros in a randomly chosen pack, stating its accompanying standard deviation.
- Find the mean and standard deviation for the sampling distribution of the mean number of defective biros per pack.
- Find the probability that for any randomly chosen pack of 50 biros, the mean number of defective biros in the pack is between 4.5 and 5.5 inclusive.
- Find the probability that of 100 packs of 50 biros each, there are at least 90 packs with mean number of defective biros per pack between 4.5 and 5.5 inclusive.

16. A box has 7 green balls and 3 red balls. Three balls are drawn without replacement from this box and the number of green balls noted. This procedure is repeated 50 times to form a sample of 50 observations. Let X : No. of green balls drawn and let \bar{X} : The mean number of green balls in the sample of 50. The standard deviation for X is $\frac{7}{10}$.

- Find the probability distribution for X stating its mean.
- State the probability distribution for \bar{X} .
- Find the probability that for any randomly chosen sample of 50 observations of X , \bar{X} is between 1 and 2 inclusive.

19.3 Simulations of a Sampling Distribution of Sample Means

- As mentioned earlier, a set of b samples each of size n will form a frequency distribution of sample means of sample size n .
 - As $b \rightarrow \infty$, the frequency distribution approaches the sampling distribution of sample means of sample size n .
- For $n \geq 30$, the sampling distribution of sample means is approximately normal with mean μ and standard deviation $\frac{\sigma}{\sqrt{n}}$.
 - Hence, for sample size $n \geq 30$ and for large b , the frequency distribution of sample means of size n should exhibit the behaviour of its sampling distribution.

Example 19.8

Consider a frequency distribution of 1 000 sample means, calculated from 1 000 samples each containing 100 observations of a random variable X with mean 10 and standard deviation 2.

- (a) State the approximate distribution for \bar{X} , the sampling distribution of sample means of sample size 100.
 (b) State the approximate distribution of the frequency distribution given.

Solution:

- (a) As sample size $100 > 30$, by the Central Limit Theorem:

\bar{X} has an approximate normal distribution with mean 10

and standard deviation $\frac{2}{\sqrt{100}} = 0.2$.

- (b) As the number of samples is large, the frequency distribution tends towards the sampling distribution of sample means of size 100.

Hence, the frequency distribution of the 1000 sample means

has an approximate normal distribution with mean 10 and standard deviation 0.2.

Example 19.9

Consider a frequency distribution of 5 000 samples means, calculated from 5 000 samples each containing 200 observations of a binomial variable X with parameters 20 and 0.4.

- (a) State the approximate distribution for \bar{X} , the sampling distribution of sample means of sample size 200.
 (b) State the approximate distribution of the frequency distribution given.

Solution:

- (a) The binomial variable X has mean $= 20 \times 0.4 = 8$

and standard deviation $= \sqrt{20 \times 0.4 \times 0.6} = \sqrt{4.8} = 2.1909$

As sample size $200 > 30$, by the Central Limit Theorem:

\bar{X} has an approximate normal distribution with mean 8

and standard deviation $\frac{\sqrt{4.8}}{\sqrt{200}} = 0.1549$.

- (b) As the number of samples is large, the frequency distribution tends towards the sampling distribution of sample means of size 200.

Hence, the frequency distribution of the sample means

has an approximate normal distribution with mean 8 and standard deviation 0.1549.

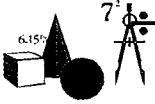

Hands On Task 19.1

(For Casio ClassPads Only)

In this task, we will use a Casio ClassPad to simulate a frequency distribution of b sample means calculated from b samples each containing n observations of a random variable, and explore the behaviour of the frequency distribution.

1. We will use the program wizard to write a simple program to perform the simulation

- Tap the Program Wizard.
- In the Program screen tap to start a new file (program).
- Give the new file a name, e.g. Sim01.
- Note down the parent folder, e.g. "Main".
- In the program editor, type the contents of the accompanying screen dump.
- Tap to save the program.
- Tap to exit the program editor.
- Tap to run the program.

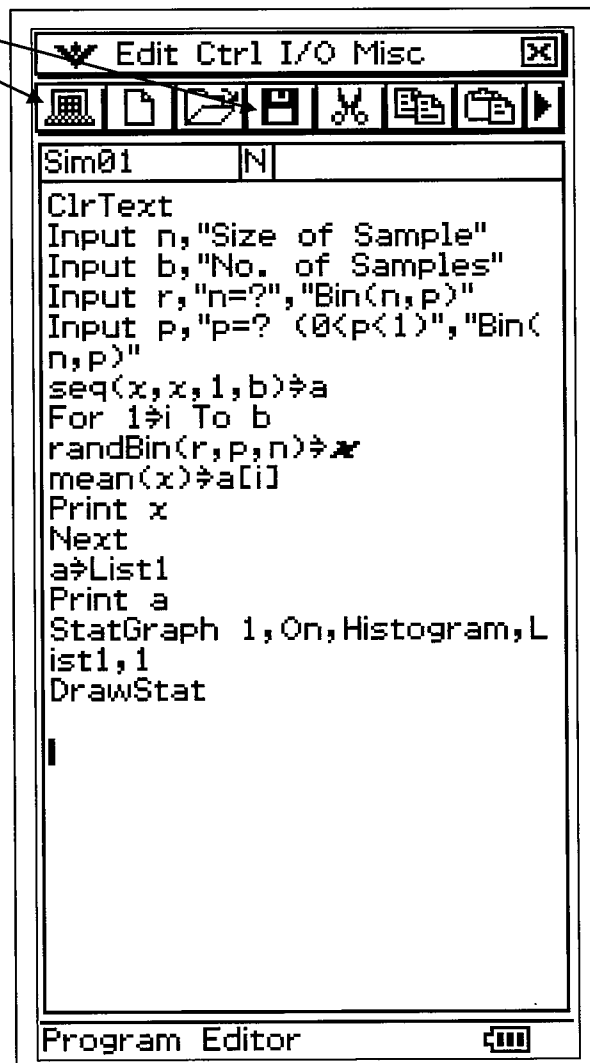
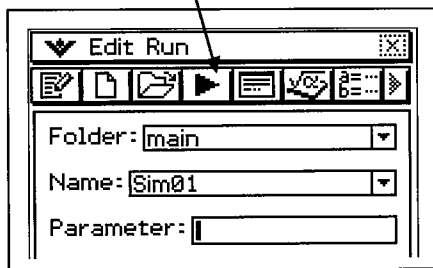
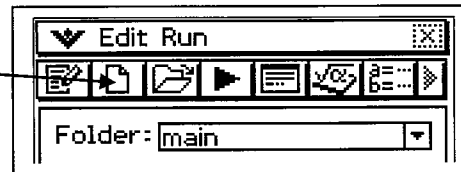

- This program will:
 - simulate b samples each containing n observations of a Binomial variable with parameters r and p .
 - calculate the mean of each sample.
 - display the frequency distribution of sample means as a list as well as a histogram.

2. Simulate 100 samples of 5 observations of a Binomial variable with parameters 10 & 0.2.

- When the program has simulated the collection of 100 samples of 5 observations and formed the frequency distribution of the sample means, a pop-up screen will appear.
- The screen allows you to set the drawing parameters of the frequency histogram.
 - Choose HStart: 0
HStep: 0.1
 - Tap OK
- The accompanying screen dump shows the final screen.
- Tap anywhere on the graph screen.
- You can analyse the graph by tapping the "Analysis" Menu and selecting the required tool.
- You can also calculate the mean of the simulated distribution and its associated standard deviation using the "Calc" Menu.
- You can have a whole lot of fun!

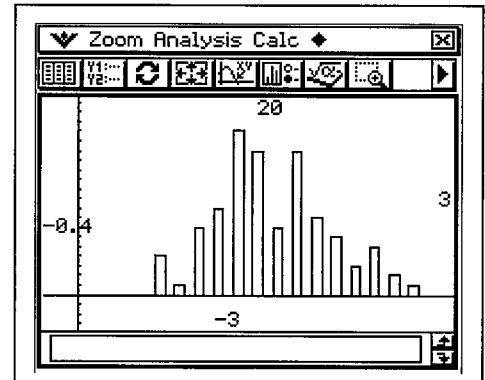
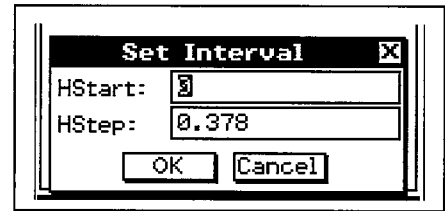

3. Simulate 100 samples of 50 observations of a Binomial variable with parameters 10 & 0.2. Be patient!

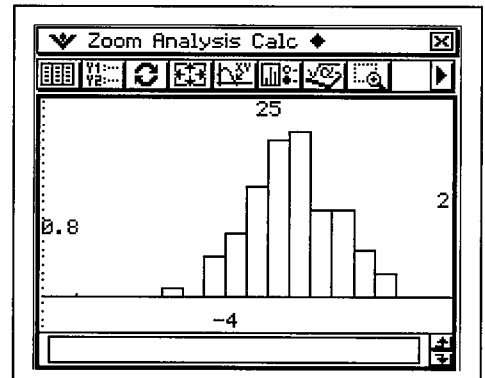

4. Create and save a new program "Sim02" to simulate b samples each containing n observations of a uniform variable in the interval $d \leq x \leq e$.

- Explore the shape of the histogram of the distribution of the sample means for various values of b and n for a common set of values for d and e .

```

Sim02  N
ClrText
Input n,"Size of Sample"
Input b,"No. of Samples"
Input d,"Start","Uniform Int
erval"
Input e,"End","Uniform Inte
rval"
seq(x,x,1,b)→a
For 1→i To b
randList(n,d,e)→x
mean(x)→a[i]
Print x
Next
a→List1
Print a
StatGraph 1,On,Histogram,L
ist1,1
DrawStat
    
```

5. Use these two programs to explore the principles of the Central Limit Theorem.

Exercise 19.3

1. Consider a frequency distribution of 5 000 sample means, calculated from 5 000 samples each containing 100 observations of a random variable X with mean 20 and standard deviation 3.
 - (a) State the approximate distribution for \bar{X} , the sampling distribution of sample means of sample size 100.
 - (b) State the approximate distribution of the frequency distribution given.

2. Consider a frequency distribution of 4 000 sample means, calculated from 4 000 samples each containing 200 observations of a random variable X with mean 100 and standard deviation 14.
 - (a) State the approximate distribution for \bar{X} , the sampling distribution of sample means of sample size 200.
 - (b) State the approximate distribution of the frequency distribution given.

3. Consider a frequency distribution of 10 000 sample means, calculated from 10 000 samples each containing 50 observations of a random variable X . The frequency distribution has mean 50 and standard deviation 5. Determine the approximate distribution for \bar{X} , the sampling distribution of sample means of sample size 50.

4. Consider a frequency distribution of 2 000 samples, each containing 100 observations of a binomial variable X with parameters 12 and 0.25.
 - (a) State the approximate distribution for \bar{X} , the sampling distribution of sample means of sample size 100.
 - (b) State the approximate distribution of the frequency distribution given.

5. Consider a frequency distribution of 1 000 sample means, calculated from 1 000 samples each containing 400 observations of a binomial variable X with parameters 10 and 0.2.
 - (a) State the approximate distribution for \bar{X} , the sampling distribution of sample means of sample size 400.
 - (b) State the approximate distribution of the frequency distribution given.

6. 10 000 samples each containing 80 observations of X , a variable uniformly distributed in the interval $[10, 20]$. A frequency distribution of the sample means is formed.
 - (a) Calculate the mean and standard deviation for X .
 - (b) State the approximate distribution for \bar{X} , the sampling distribution of sample means of sample size 80.
 - (c) State the approximate distribution of the frequency distribution stated.

7. The random variable X has probability distribution function $f(x) = \frac{3x^2}{2}$ for $-1 \leq x \leq 1$. 8 000 samples each containing 120 observations of X were taken and a frequency distribution of the sample means formed.
 - (a) Calculate the mean and standard deviation for X .
 - (b) State the approximate distribution of the frequency distribution of sample means.

20 Point & Interval Estimates for μ

20.1 Point Estimate for population mean μ

- Assume that we need to find the mean height of all year 12 students in a particular state. Short of “rounding up” all the year 12 students in the state and measuring their heights, we could use samples to estimate the mean height of these students.
 - A sample of n year 12 students is obtained, and the mean of this sample $\bar{x} = \frac{\sum x}{n}$ may be used to estimate the mean height of all year 12 students in this state.
 - In general, where the population mean μ is unknown, a sample mean (the mean of one sample) may be used in its place.
- As the sample mean is a single number, it is referred to as a *point estimate* (single-value estimate) for the population mean μ .

20.2 Point Estimate for population standard deviation σ

- The standard deviation σ for a set of n scores with mean \bar{x} measures the variability of the scores about the mean and is calculated using the formula

$$\sigma = \frac{1}{\sqrt{n}} \sqrt{\sum (x - \bar{x})^2} = \frac{1}{\sqrt{n}} \sqrt{(\sum x^2) - (\bar{x})^2}$$

- Assume that the standard deviation σ of a population of scores is not known. A sample of n scores is extracted from this population.
 - To estimate the standard deviation σ of this population from the sample of n scores, the value derived from the formula

$$s = \frac{1}{\sqrt{n-1}} \sqrt{\sum (x - \bar{x})^2} \text{ is used.}$$

- This is referred to as the *sample standard deviation* for the sample of n scores.
- In summary:
 - To *describe* the dispersion of n scores about its mean, the standard deviation $\sigma = \frac{1}{\sqrt{n}} \sqrt{\sum (x - \bar{x})^2}$ is used.
 - To *estimate* the standard deviation of the population set from which a sample of n scores is drawn, the sample standard deviation $s = \frac{1}{\sqrt{n-1}} \sqrt{\sum (x - \bar{x})^2}$ is used.

Example 20.1

To estimate the mean height and its associated standard deviation of year 12 students in a school, a random sample of 10 students were selected. The heights (cm) of these students were: 179, 165, 168, 159, 165, 170, 158, 163, 167 & 164. With the help of a calculator, use this sample to find point estimates for the mean height and its associated standard deviation, of all year 12 students in this school.

Solution:

From calculator:

The sample mean = 165.8 cm.

The sample standard deviation = 5.94.

Hence, an estimate for the mean height of year 12 students in the school = 165.8 cm and an estimate for its standard deviation = 5.94 cm.

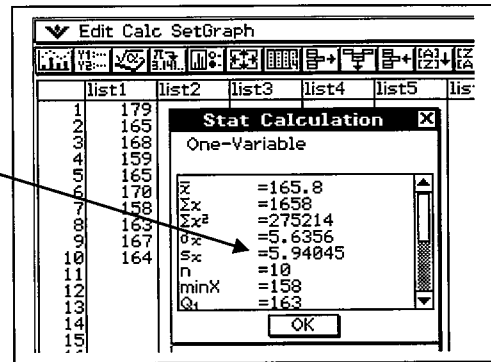
**Note:**

- In most CAS calculators, the sample standard deviation is s_x . σ_x is the standard deviation for this set.

20.3 Sampling distributions of sample means when σ is not known

- Consider a sampling distribution of sample means of sample size n . The sampling distribution share the same mean μ as the population mean. The standard deviation of the sampling distribution is $\frac{\sigma}{\sqrt{n}}$ where σ is the standard deviation of the parent.
- When the population standard deviation σ is unknown, σ may be estimated by a *sample standard deviation* s if:
 - the parent population is normal
 - or the sample size n is large (≥ 30).
- Combining this with the Central Limit Theorem, if the sample size n is large (≥ 30) then, the sampling distribution of means will have an approximate normal distribution with mean μ and standard deviation $\frac{s}{\sqrt{n}}$.

- That is, if $n \geq 30$, $\bar{X} \sim N\left(\mu, \left(\frac{s}{\sqrt{n}}\right)^2\right)$

where s is a sample standard deviation estimate for the population standard deviation σ .

Example 20.2

A random variable X has mean 50. 500 samples of 100 observations each are taken of X and \bar{X} the means for each sample calculated. One of the samples of 100 observations of X has a sample standard deviation 2.8. Use this information to describe the probability distribution for \bar{X} and the frequency distribution of sample means.

Solution:

The population standard deviation is not known and is estimated by the sample standard deviation of 2.8 provided.

As the size of the sample = 100 > 30,

\bar{X} is approximately normally distributed with mean = 50

and standard deviation = $\frac{2.8}{\sqrt{100}} = 0.28$.

As the number of samples is large, the frequency distribution tends towards the sampling distribution of sample means of size 100.

Hence, the frequency distribution of the 500 sample means

has an approximate normal distribution with mean 50 and standard deviation 0.28.

20.4 Probability distribution of $\frac{\bar{X} - \mu}{\left(\frac{s}{\sqrt{n}}\right)}$

- Consider b samples each with n observations of a random variable X with mean μ .
 - For each sample, the sample mean \bar{x} , the sample standard deviation s and the statistic $\frac{\bar{X} - \mu}{\left(\frac{s}{\sqrt{n}}\right)}$ is calculated.

- Hence, we have a distribution of $\frac{\bar{X} - \mu}{\left(\frac{s}{\sqrt{n}}\right)}$.

- It can be shown that for large n ($n \geq 30$), this distribution will be approximately standard normal. That is, for $n \geq 30$:

$$\frac{\bar{X} - \mu}{\left(\frac{s}{\sqrt{n}}\right)} \sim N(0, 1).$$

- As the number of samples b increases in size, the frequency distribution of $\frac{\bar{x} - \mu}{\left(\frac{s}{\sqrt{n}}\right)}$ will tend towards the distribution of $\frac{\bar{X} - \mu}{\left(\frac{s}{\sqrt{n}}\right)}$.

Example 20.3

2 000 samples of 100 observations each are taken of a random variable with probability

density function $f(x) = \frac{4-x}{8}$ for $0 \leq x \leq 4$. For each sample, the statistic $\frac{\bar{X} - \mu}{\left(\frac{s}{\sqrt{n}}\right)}$ is

calculated, where μ is the mean for X , and s is the sample standard deviation.

(a) Find the mean and standard deviation for X .

(b) Describe the distribution for \bar{X} .

(c) Describe the distribution for $\frac{\bar{X} - \mu}{\left(\frac{s}{\sqrt{n}}\right)}$ and the frequency distribution of $\frac{\bar{x} - \mu}{\left(\frac{s}{\sqrt{n}}\right)}$.

Solution:

$$(a) \text{ Mean for } X = E(X) = \int_0^4 x \times \left(\frac{4-x}{8}\right) dx = \frac{4}{3}.$$

$$\begin{aligned} \text{Variance for } X &= E(X^2) - [E(X)]^2 \\ &= \int_0^4 x^2 \times \left(\frac{4-x}{8}\right) dx - \left(\frac{4}{3}\right)^2 \\ &= \frac{8}{3} - \frac{16}{9} = \frac{8}{9} \end{aligned}$$

$$\text{Hence, standard deviation} = \frac{2\sqrt{2}}{3}.$$

(b) As sample size $n = 100 > 30$,

\bar{X} is approximately normal with mean = $\frac{4}{3}$

$$\text{and standard deviation} = \left(\frac{\frac{2\sqrt{2}}{3}}{\sqrt{100}}\right) = \frac{\sqrt{2}}{15}.$$

Handwritten solution for part (a):

$$\int_0^4 x \times \frac{(4-x)}{8} dx = \frac{4}{3}$$

$$\int_0^4 x^2 \times \frac{(4-x)}{8} dx = \frac{8}{3}$$

$$\sqrt{\frac{8}{3} - \left(\frac{4}{3}\right)^2} = \frac{2 \cdot \sqrt{2}}{3}$$

$$\frac{2 \cdot \sqrt{2}}{3} / 10 = \frac{\sqrt{2}}{15}$$

(c) As $n = 100 > 30$ and b is large, the distribution for $\frac{\bar{X} - \mu}{\left(\frac{s}{\sqrt{n}}\right)}$

and the frequency distribution of $\frac{\bar{x} - \mu}{\left(\frac{s}{\sqrt{n}}\right)}$ will be approximately standard normal.

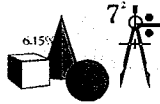

Hands On Task 20.1

(For Casio ClassPads Only)

In this task, we will make use of a Casio ClassPad to observe how the variable $\frac{\bar{X} - \mu}{\left(\frac{s}{\sqrt{n}}\right)}$ tends towards a standard normal distribution.

1. Create and save a new program “Sim03” to:

- simulate b samples each containing n observations of a Binomial variable X with parameters r and p .
- calculate \bar{x} and s , respectively the mean and sample standard deviation of each sample and hence calculate the value of $\frac{\bar{X} - \mu}{\left(\frac{s}{\sqrt{n}}\right)}$ for each sample.
- display the frequency histogram for $\frac{\bar{X} - \mu}{\left(\frac{s}{\sqrt{n}}\right)}$.

```

Sim03  |N|
ClrText
Input n,"Size of Sample"
Input b,"No. of Samples"
Input r,"n=?","Bin(n,p)"
Input p,"p=? (0<p<1)","Bin(n,p)"
seq(x,x,1,b)→a
For i To b
  randBin(r,p,n)→x
  (mean(x)-r×p)×n/stdDev(x)→a[i]
Print x
Next
a→List1
Print a
StatGraph 1,On,Histogram,List1,1
DrawStat
    
```

2. Create and save a new program “Sim04” to:

- simulate b samples each containing n observations of a uniform variable in the interval $d \leq x \leq e$.
- calculate \bar{x} and s , respectively the mean and sample standard deviation of each sample and hence calculate the value of $\frac{\bar{X} - \mu}{\left(\frac{s}{\sqrt{n}}\right)}$ for each sample.

```

Sim04  |N|
ClrText
Input n,"Size of Sample"
Input b,"No. of Samples"
Input d,"Start","Uniform Interval"
Input e,"End","Uniform Interval"
seq(x,x,1,b)→a
For i To b
  randList(n,d,e)→x
  (mean(x)-0.5×(d+e))×n/stdDev(x)→a[i]
Print x
Next
a→List1
Print a
StatGraph 1,On,Histogram,List1,1
DrawStat
    
```

- display the frequency histogram for $\frac{\bar{X} - \mu}{\left(\frac{s}{\sqrt{n}}\right)}$.

3. Use these two programs to explore the shape of the frequency histogram for

$\frac{\bar{X} - \mu}{\left(\frac{s}{\sqrt{n}}\right)}$ to observe how $\frac{\bar{X} - \mu}{\left(\frac{s}{\sqrt{n}}\right)}$ tends towards a standard normal variable for large values of n ($n \geq 30$).

Exercise 20.1

1. To estimate the mean mass of year 12 students in a school, a random sample of 20 students were selected. The masses (kg) of these students were:
 63.4, 54.6, 56.5, 69.2, 59.4, 61.5, 45.6, 66.7, 49.8, 57.3,
 62.4, 63.1, 64.2, 58.7, 56.1, 55.3, 59.4, 62.4, 67.3, 57.8
- (a) Find the mean and sample standard deviation for this sample.
 (b) Use this sample to find an estimate for the mass and its associated standard deviation, of all year 12 students in this school.

2. To estimate the daily travelling times to school, 60 students were surveyed. The results are shown in the accompanying table.
- (a) Use this sample to estimate the mean daily travelling times to school for all the students in this school, together with its standard deviation.
 (b) Hence, state the probability distribution for the sample mean daily travelling times to school.

Travelling Time (mins)	No. of Students
$0 < t \leq 5$	5
$5 < t \leq 10$	20
$10 < t \leq 15$	15
$15 < t \leq 20$	10
$20 < t \leq 25$	5
$25 < t \leq 30$	3
$30 < t \leq 60$	2

3. A random variable X has mean 100. 1 000 samples of 200 observations each are taken of X and \bar{X} the mean for each sample calculated. The sample standard deviation of one of the samples of 200 observations of X has a sample standard deviation 15. State the probability distribution for \bar{X} and the frequency distribution of sample means.
4. The diameters of 5 000 samples of 50 ball bearings each were measured. The mean diameter of one of the samples is 10 mm with a sample standard deviation of 0.1 mm. State the approximate probability distribution for \bar{X} and the frequency distribution of sample means.
5. 2 000 samples of 100 observations each are taken of a binomial variable with parameters 6 and $\frac{1}{6}$. For each sample the statistic $(\bar{X}-\mu)/\left(\frac{s}{\sqrt{n}}\right)$ is calculated, where μ is the mean for X , and s is the sample standard deviation.
- (a) Find the mean and standard deviation for \bar{X} and state the distribution for \bar{X}
 (b) Describe the probability distribution for $\frac{\bar{X}-\mu}{\left(\frac{s}{\sqrt{n}}\right)}$.
6. 2 000 samples of 100 observations each are taken of a variable distributed uniformly in the interval $[0, 10]$. For each sample the statistic $(\bar{X}-\mu)/\left(\frac{s}{\sqrt{n}}\right)$ is calculated, where μ is the mean for X , and s is the sample standard deviation.
- (a) Find the mean and standard deviation for \bar{X} and state the distribution for \bar{X}
 (b) Describe the distribution for $\frac{\bar{X}-\mu}{\left(\frac{s}{\sqrt{n}}\right)}$ and the frequency distribution of $\frac{\bar{x}-\mu}{\left(\frac{s}{\sqrt{n}}\right)}$.

7. 30 observations of a random variable X with mean $\mu = 1$ are given below.

0	0	2	2	1	0	2	1	1	1
1	1	1	2	0	1	0	3	1	1
1	3	0	2	0	0	3	0	1	2

(a) Calculate the mean \bar{x} , standard deviation and sample standard deviation s for this sample.

(b) For this sample, calculate the corresponding value of the statistic $\frac{\bar{X}-\mu}{\left(\frac{s}{\sqrt{n}}\right)}$.

8. 30 observations of a random variable X with mean $\mu = 10.5$ are given below.

13	9	11	8	4	10	13	12	2	11
13	11	9	2	8	13	15	7	19	18
16	8	12	12	18	20	7	20	2	19

(a) Calculate the mean \bar{x} , standard deviation and sample standard deviation s for this sample.

(b) For this sample, calculate the corresponding value of the statistic $\frac{\bar{X}-\mu}{\left(\frac{s}{\sqrt{n}}\right)}$.

20.5 Interval Estimates

- When different samples (unbiased) are taken, estimates for the population mean will vary. This is a disadvantage of using point estimates.
- Interval estimates for the population mean involve using a sample to provide an interval of values for estimating the population mean.

20.5.1 Confidence Intervals for μ

- A confidence interval for μ :
 - uses the mean of a sample \bar{x} as a point estimate for μ ,
 - provides a margin of error ($\pm e$) for the point estimate \bar{x} , thereby providing an interval of possible values for μ , $\bar{x} - e \leq \mu \leq \bar{x} + e$,
 - and a statement of confidence in percentage terms that μ would lie within the interval of values calculated.

20.5.2 Calculating Confidence Intervals

- Let the random variable X be normally distributed with mean μ and standard deviation σ . Samples of n observations are taken of X . Then, the sampling distribution of the sample means \bar{X} will be normally distributed with mean μ and standard deviation (standard error) $\frac{\sigma}{\sqrt{n}}$.

- Consider $P(\mu - k \leq \bar{X} \leq \mu + k) = 0.90$.

$$\Rightarrow P\left(\frac{-k}{\left(\frac{\sigma}{\sqrt{n}}\right)} \leq Z \leq \frac{k}{\left(\frac{\sigma}{\sqrt{n}}\right)}\right) = 0.90.$$

$$\text{But } \frac{k}{\left(\frac{\sigma}{\sqrt{n}}\right)} = 1.645. \quad \Rightarrow k = 1.645 \times \left(\frac{\sigma}{\sqrt{n}}\right).$$

$$\Rightarrow P\left(\mu - 1.645 \times \left(\frac{\sigma}{\sqrt{n}}\right) \leq \bar{X} \leq \mu + 1.645 \times \left(\frac{\sigma}{\sqrt{n}}\right)\right) = 0.90. \quad (I)$$

(I) can be rearranged to give:

$$P\left(\bar{X} - 1.645 \times \left(\frac{\sigma}{\sqrt{n}}\right) \leq \mu \leq \bar{X} + 1.645 \times \left(\frac{\sigma}{\sqrt{n}}\right)\right) = 0.90. \quad (II)$$

- (II) states that there is a 90% probability that μ will lie in the interval $\bar{X} \pm 1.645 \left(\frac{\sigma}{\sqrt{n}}\right)$. If \bar{x} is a point estimate for μ , then, we are 90% *confident* that the interval $\bar{x} \pm 1.645 \left(\frac{\sigma}{\sqrt{n}}\right)$ will contain μ . This interval is known as the 90% *confidence interval* for μ .

- Similarly, the 95% confidence interval for μ is $\bar{x} \pm 1.960 \left(\frac{\sigma}{\sqrt{n}}\right)$.

- Likewise, the 99% confidence interval for μ is $\bar{x} \pm 2.576 \left(\frac{\sigma}{\sqrt{n}}\right)$.

- In general, if X is normally distributed and σ is known, a $100c\%$ confidence interval for μ is given by $\bar{x} - z_c \times \frac{\sigma}{\sqrt{n}} < \mu < \bar{x} + z_c \times \frac{\sigma}{\sqrt{n}}$ where $P(-z_c < Z < z_c) = c$.

- If X is not normally distributed and σ is known, for sample sizes $n \geq 30$: an approximate $100c\%$ confidence interval for μ is given by

$$\bar{x} - z_c \times \frac{\sigma}{\sqrt{n}} < \mu < \bar{x} + z_c \times \frac{\sigma}{\sqrt{n}}$$

where $P(-z_c < Z < z_c) = c$.

- In each of the above two cases, if σ is not known, the sample standard deviation s can be used as a point estimate for σ .

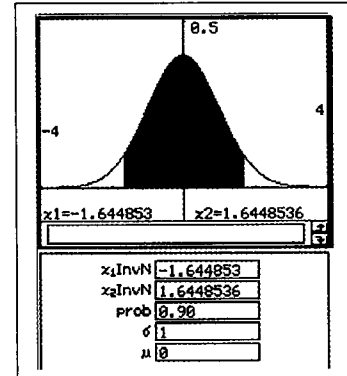

- Clearly, different samples will yield varying interval estimates of the same confidence level $100c\%$ for μ . However, from repeated sampling, $100c\%$ of the interval estimates obtained will actually contain μ .
- That is, the confidence level of $100c\%$ refers to the percentage of intervals obtained through repeated sampling (of the same size) that will contain μ .
- In summary, a $100c\%$ confidence interval for μ :
 - uses the mean of a sample \bar{x} as a point estimate for μ ,
 - provides a margin of error $(\pm z_c \times \frac{\sigma}{\sqrt{n}})$ for the point estimate \bar{x} ,
thereby providing an interval of possible values for μ , $\bar{x} \pm z_c \times \frac{\sigma}{\sqrt{n}}$,
 - provides a statement of confidence in percentage terms that through repeated sampling, $100c\%$ of intervals $\bar{x} \pm z_c \times \frac{\sigma}{\sqrt{n}}$ obtained will contain μ .
- The table below summarises the different confidence intervals for μ .

Confidence Intervals	Parent Distribution			
	Normal Mean μ		Non-Normal Mean μ with sample size $n \geq 30$	
	σ known	σ unknown	σ known	σ unknown
90%	$\bar{x} \pm 1.645 \times \left(\frac{\sigma}{\sqrt{n}}\right)$	$\bar{x} \pm 1.645 \times \left(\frac{s}{\sqrt{n}}\right)$	$\bar{x} \pm 1.645 \times \left(\frac{\sigma}{\sqrt{n}}\right)$	$\bar{x} \pm 1.645 \times \left(\frac{s}{\sqrt{n}}\right)$
95%	$\bar{x} \pm 1.960 \times \left(\frac{\sigma}{\sqrt{n}}\right)$	$\bar{x} \pm 1.960 \times \left(\frac{s}{\sqrt{n}}\right)$	$\bar{x} \pm 1.960 \times \left(\frac{\sigma}{\sqrt{n}}\right)$	$\bar{x} \pm 1.960 \times \left(\frac{s}{\sqrt{n}}\right)$
99%	$\bar{x} \pm 2.576 \times \left(\frac{\sigma}{\sqrt{n}}\right)$	$\bar{x} \pm 2.576 \times \left(\frac{s}{\sqrt{n}}\right)$	$\bar{x} \pm 2.576 \times \left(\frac{\sigma}{\sqrt{n}}\right)$	$\bar{x} \pm 2.576 \times \left(\frac{s}{\sqrt{n}}\right)$
$100c\%$	$\bar{x} \pm z_c \times \left(\frac{\sigma}{\sqrt{n}}\right)$	$\bar{x} \pm z_c \times \left(\frac{s}{\sqrt{n}}\right)$	$\bar{x} \pm z_c \times \left(\frac{\sigma}{\sqrt{n}}\right)$	$\bar{x} \pm z_c \times \left(\frac{s}{\sqrt{n}}\right)$
$100(1 - \alpha)\%$	$\bar{x} \pm z_{\frac{\alpha}{2}} \times \left(\frac{\sigma}{\sqrt{n}}\right)$	$\bar{x} \pm z_{\frac{\alpha}{2}} \times \left(\frac{s}{\sqrt{n}}\right)$	$\bar{x} \pm z_{\frac{\alpha}{2}} \times \left(\frac{\sigma}{\sqrt{n}}\right)$	$\bar{x} \pm z_{\frac{\alpha}{2}} \times \left(\frac{s}{\sqrt{n}}\right)$

- Note that $P(-z_c \leq Z \leq z_c) = c$ and $P(-z_{\frac{\alpha}{2}} \leq Z \leq z_{\frac{\alpha}{2}}) = 1 - \alpha$.
- If X is not a normal variable, for $n \geq 30$, the confidence interval is at best an *approximate confidence interval*. Similarly, if the sample standard deviation is used as an estimate for the unknown population standard deviation σ , for $n \geq 30$, the confidence interval is at best an *approximate confidence interval*.
- Note that the higher the level of confidence, the wider the confidence interval.

Example 20.4

The random variable X is normally distributed with mean μ and standard deviation 12. A sample of 25 observations of X was taken. The mean value of these observations $\bar{x} = 60.1$. Use the sampling distribution of the sample means \bar{X} to find a 99% confidence interval for μ .

Solution:

Since X is normal, $\bar{X} \sim N(\mu, \frac{12^2}{25})$.

For a 99% confidence interval for μ :

$$P(\mu - k \leq \bar{X} \leq \mu + k) = 0.99.$$

$$\Rightarrow P\left(\frac{-k}{2.4} \leq Z \leq \frac{k}{2.4}\right) = 0.99.$$

But $\frac{-k}{2.4} = -2.576$. $\Rightarrow k = 6.1824$

$$\Rightarrow P(\mu - 6.1824 \leq \bar{X} \leq \mu + 6.1824) = 0.99.$$

$$P(\bar{X} - 6.1824 \leq \mu \leq \bar{X} + 6.1824) = 0.99.$$

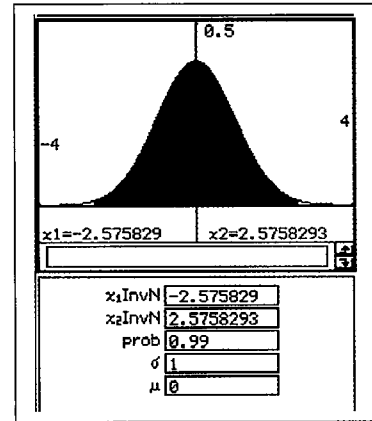

Taking the sample mean $\bar{X} = 60.1$, a 99% confidence interval for μ is:

$$60.1 - 6.1824 \leq \mu \leq 60.1 + 6.1824$$

$$53.9 \leq \mu \leq 66.3 .$$

Example 20.5

The random variable X is normally distributed with mean μ and standard deviation 12. A sample of 25 observations of X was taken. The mean value of these observations $\bar{x} = 60.1$. Use a CAS/graphic calculator to find a 99% confidence interval for μ .

Solution:

Since X is normal, $\bar{X} \sim N(\mu, \frac{12^2}{25})$.

Take the sample mean $\bar{X} = 60.1$ as a point estimate for μ .

Hence, a 99% confidence interval for μ is: $53.9 \leq \mu \leq 66.3$.

Example 20.6

The random variable X has mean μ and standard deviation σ . A sample of 50 observations of X was taken. The mean value of these observations $\bar{x} = 32.6$ with a sample standard deviation of 3.4. Find an approximate (i) 95% (ii) 98% confidence interval for μ .

Solution:

As the sample size $n = 50 \geq 30$, \bar{X} is normally distributed.

Use $\bar{x} = 32.6$ as a point estimate for μ and $s = 3.4$ as a point estimate for σ .

(a) Hence, a 95% confidence interval for μ is $32.6 \pm 1.96 \times \frac{3.4}{\sqrt{50}} = 32.6 \pm 0.94$.

(b) $P(-z_c < Z < z_c) = c \Rightarrow z_c = 2.326$

Hence, a 98% confidence interval for μ is:

$$32.6 \pm 2.326 \times \frac{3.4}{\sqrt{50}} = 32.6 \pm 1.12$$

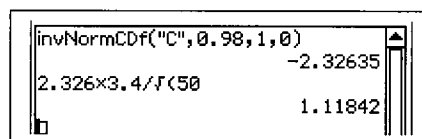

Example 20.7

The normal variable X has mean μ and standard deviation 11.8. A sample of n observations of X was taken. The mean value of these observations $\bar{x} = 50.2$.

(a) Find n if the error for the 95% confidence interval of μ is not to exceed 2.

(b) For $n = 25$, find the level of confidence for a confidence interval for μ with an error of ± 5 .

Solution:

(a) Since X is normally distributed, the error for the 95% confidence interval is

$$e = \pm 1.96 \times \left(\frac{11.8}{\sqrt{n}} \right).$$

Hence, for margin of error ≤ 2 :

$$1.96 \times \left(\frac{11.8}{\sqrt{n}} \right) \leq 2$$

$$\Rightarrow n \geq 134.$$

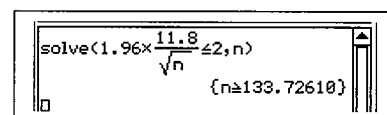

(b) $e = \pm 5 \Rightarrow z_c \times \left(\frac{11.8}{\sqrt{25}} \right) = 5$

$$z_c = 2.11864$$

But $P(-2.11864 \leq Z \leq 2.11864) = 0.9659$.

Hence, level of confidence is 96.6%

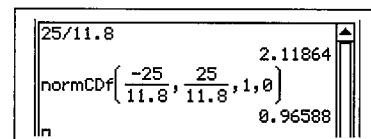

Note:

- The error for a confidence interval is the difference between the point estimate \bar{x} and the true mean μ .

Example 20.8

The random variable X has mean μ and standard deviation σ . A large sample of n observations of X was taken. The mean value of these observations $\bar{x} = 670$ with sample standard deviation 54.5. Find n if we wish to be 99% confident that the sample mean will not differ from the true mean by more than 20.

Solution:

Since the sample size is large, the sampling mean \bar{X} is approximately normally distributed. Using \bar{x} as the point estimate for μ and s as the point estimate for σ ;

an approximate 99% confidence interval is $670 \pm 2.576 \times \frac{54.5}{\sqrt{n}}$.

Hence, the magnitude of the margin of error :

$$2.576 \times \frac{54.5}{\sqrt{n}} \leq 20.$$

$$\Rightarrow n \geq 50$$

Alternative Solution:

Since the sample size is large, the sampling mean \bar{X} is approximately normally distributed. Using \bar{x} as the point estimate for μ and s as the point estimate for σ ;

$$P(-20 \leq \bar{X} - \mu \leq 20) = 0.99$$

$$\Rightarrow P\left(\frac{-20}{\left(\frac{54.5}{\sqrt{n}}\right)} \leq \frac{\bar{X} - \mu}{\left(\frac{54.5}{\sqrt{n}}\right)} \leq \frac{20}{\left(\frac{54.5}{\sqrt{n}}\right)}\right) = 0.99$$

$$P\left(\frac{-20}{\left(\frac{54.5}{\sqrt{n}}\right)} \leq Z \leq \frac{20}{\left(\frac{54.5}{\sqrt{n}}\right)}\right) = 0.99$$

But $P(-2.576 \leq Z \leq 2.576) = 0.99$

Hence, $\frac{20}{\left(\frac{54.5}{\sqrt{n}}\right)} = 2.576$

$$\Rightarrow n = 50.$$

For $n = 50$, the maximum difference of 20 between \bar{x} and μ is achieved. Hence, if the difference is to be no more than 20, $n \geq 50$.

Example 20.9

The mean amount of time spent watching television by 5 year olds in a certain country is μ with standard deviation σ . Samples of size n of 5 year olds were taken, and one such sample yielded the mean watching time as 180 minutes with sample standard deviation 45 minutes.

- (a) For $n = 100$, find a 90% confidence interval for μ .
- (b) Find n if the margin of error for a 99.9% confidence interval for μ is less than 20 minutes.

Solution:

(a) Since the sample size is large, the sampling mean \bar{X} is approximately normally distributed. Using \bar{x} as the point estimate for μ and s_x as the point estimate for σ ; the approximate 90% confidence interval is $180 \pm 1.645 \times \frac{45}{\sqrt{100}} = 180 \pm 7.4$ minutes.

(b) Assume that $n \geq 30$. Hence, \bar{X} is approximately normal.
 $P(-3.2905 \leq Z \leq 3.2905) = 0.999$.

Hence, margin of error for a 99.9% confidence interval $e = 3.2905 \times \frac{45}{\sqrt{n}}$.

$$\Rightarrow 3.2905 \times \frac{45}{\sqrt{n}} < 20 \Rightarrow n \geq 55$$

Example 20.10

The height X of year 12 students in a certain state is normally distributed with mean μ and standard deviation σ . The mean height of a sample of 100 students is 165.4 cm with a sample standard deviation of 4.8 cm. Use the sample mean and sample standard deviation as point estimates for μ and σ respectively

- (a) The probability that the height of the next student chosen lies in the interval $\mu - k \leq X \leq \mu + k$ is 0.95. Determine the approximate value of k .
- (b) Find an approximate 95% confidence interval for μ .
- (c) Discuss the interpretation of your answers in (a) and (b).

Solution:

(a) Use $\mu \approx 165.4$ and $\sigma \approx 4.8$

Hence, $X \sim N(165.4, 4.8^2) \Rightarrow \frac{X-165.4}{4.8} \sim N(0, 1)$.

$$P(165.4 - k \leq X \leq 165.4 + k) = 0.95$$

$$\Rightarrow P\left(-\frac{k}{4.8} \leq \frac{X-165.4}{4.8} \leq \frac{k}{4.8}\right) = 0.95$$

$$P\left(-\frac{k}{4.8} \leq Z \leq \frac{k}{4.8}\right) = 0.95$$

$$\Rightarrow \frac{k}{4.8} = 1.96 \Rightarrow k = 9.408.$$

```
solve(normCDF(165.4-x, 164.5+x, 4.8, 165.4)=0.95, x)
{x=9.899028168}
```

(b) Approximate 95% confidence interval for μ is $165.4 \pm 1.96 \times \frac{4.8}{\sqrt{100}}$.

That is: $164.5 \leq \mu \leq 166.3$ cm

(c) In (a), the 95% value refers to the probability that the height of the next student chosen will be between a certain interval. Whereas, in (b), the 95% value refers to the percentage of intervals calculated that will contain μ .

Notes:

- It is incorrect to interpret the confidence interval as implying that the probability that μ lies between 163.6 cm and 165.4 cm is 95%.
- As μ is a constant, it is either inside the interval or it is not. That is, the probability that μ is in the given interval is either 0 or 1.

Exercise 20.2

1. The random variable X is normally distributed with mean μ and standard deviation 4.8. A sample of 20 observations of X was taken and the mean value $\bar{x} = 33.7$.
 - (a) State the probability distribution for the sampling distribution for \bar{X} .
 - (b) Find a (i) 99% (ii) 92% confidence interval for μ .
 - (c) Find the size of the next sample of observations of X if the error margin for a 95% confidence interval for μ is no more than 2.

2. The random variable X is normally distributed with mean μ and standard deviation σ . A sample of 16 observations of X was taken. The mean value of these observations $\bar{x} = 201.4$ with a sample standard deviation of 14.1.
 - (a) State the probability distribution for the sampling distribution for \bar{X} .
 - (b) Find an approximate (i) 90% (ii) 97% confidence interval for μ .
 - (c) Find the size of the next sample of observations of X if we wish to be 95% confident that the estimate for the mean is not to differ from the true mean μ by more than 4.

3. The random variable X has mean μ and standard deviation 1.2. A sample of 100 observations of X was taken. The mean value of these observations $\bar{x} = 5.4$
 - (a) State the probability distribution for the sampling distribution for \bar{X} .
 - (b) Find an approximate (i) 95% (ii) 99.5% confidence interval for μ .
 - (c) Find the size of the next sample of observations of X if the probability that the estimate for the mean is not to differ from the true mean μ by more than 0.2 is 0.9.

4. The random variable X has mean μ and standard deviation σ . A sample of 80 observations of X was taken. The mean value of these observations $\bar{x} = 20.7$ with sample standard deviation $s_x = 3.1$.
- Find an approximate (i) 90% (ii) 99.9% confidence interval for μ .
 - Another sample of n observations of X was taken. Find n if the probability that the error between the sample mean and the true mean is no more than 1 is 0.97.
5. The time (seconds) taken to complete a certain task is normally distributed with mean μ and standard deviation 35 seconds. A sample of size n such completion times has mean 485 seconds.
- Find the probability that: (i) the time to complete the task exceeds 500 seconds.
(ii) a sample of size 25 has a mean completion time that exceeds 500 seconds.
 - For $n = 100$, find a (i) 90% (ii) 92% confidence interval for μ .
 - Find n if the error for a 99.5% confidence interval for μ is less than 20 seconds.
6. The amount of water used per shower at Julia's home is normally distributed with mean μ and standard deviation σ . The amount of water Julia used for her shower was measured over n occasions and the mean amount of water used per shower was 125 litres with a sample standard deviation of 12 litres.
- Find the probability that for the next sample of 40 showers the total amount of water used is less than 5.12 kilolitres.
 - For a sample of 40 showers, find a 99% confidence for μ .
 - Find n if the probability that estimate for μ is in error by no more than 5 litres is 97%.
7. The waiting time (minutes) at a pharmacy drug dispensing counter is uniformly distributed with mean μ and variance $\frac{75}{4}$. The waiting times of a sample of 30 customers were recorded and the mean waiting time for this sample is 12 minutes.
- Find the probability that the next sample of 30 customers will have a mean waiting time not exceeding 11 minutes.
 - For a sample of 30 customers, find a 95% confidence interval for μ .
 - For another sample of 30 customers, find the level of confidence if the confidence interval for μ has an error of ± 1 minute.
8. The amount of chemical X dispensed per use by a dispenser is uniformly distributed with mean μ g and standard deviation σ g. The dispenser was used 90 times and the mean amount of chemical X dispensed per use was 2.5 g with sample standard deviation 0.3 g.
- Find the probability that the total amount of chemical X dispensed when used 90 times will be no more than 230 g.
 - Find an approximate 99.5% confidence interval for μ .
 - Find the level of confidence for a confidence interval for μ with error ± 50 mg.

9. A radioactive substance emits particles randomly. The mean time interval between successive emissions is μ seconds with a standard deviation of 6 seconds. Assume that the particles are emitted independently and no two particles are emitted at the same time. It took a total of 5 hours and 5 minutes to record a sample of 100 successive emissions.
- Find an approximate 95% confidence interval for μ
 - Find the level of confidence for a confidence interval for μ with error ± 1 second.
 - How large should the next sample of emission time intervals be if we wish to be 80% confident that the estimate for the mean is not to differ from the true mean μ by more than 1 second?
10. The time (X minutes) that Georgia takes to drive to school is normally distributed with mean μ and standard deviation σ . From a sample of 50 trips made, the mean time was 30 minutes with a sample standard deviation of 1 minute. Use the sample mean and sample standard deviation as point estimates for μ and σ respectively.
- The probability that the travel time for Georgia's next trip falls in the interval $\mu - k \leq X \leq \mu + k$ is 0.90. Determine the approximate value of k .
 - Find an approximate 90% confidence for μ .
 - Discuss the interpretation of your answers in (a) and (b).
11. A factory manufactures precision screws with mean length μ mm and standard deviation σ mm. A sample of 500 screws has a mean length of 10.00 mm with standard deviation 0.1 mm.
- Calculate approximate 90%, 95% and 99% confidence intervals for μ .
 - A second sample of 500 screws had a mean length of 10.01 mm. Use your answers in (a) to determine if there is cause to infer that the second batch of screws are longer than those in the first sample
12. A factory packs sugar in bags with mean mass μ g and standard deviation σ g. A sample of 300 bags of sugar had a mean mass of 1000 g with standard deviation 2 g.
- Calculate approximate 90%, 95% and 99% confidence intervals for μ .
 - A second sample of 100 bags of sugar had a mean mass of 999.8 g. Use your answers in (a) to determine if there is cause to infer that the second batch of bags are lighter than those in the first sample

20.6 Level of significance

- Let $X \sim N(\mu, \sigma^2)$.
Samples of n observations on X are taken and \bar{X} , the mean value of X for each sample is calculated.
- Clearly the sampling distribution for $\bar{X} \sim N(\mu, \frac{\sigma^2}{n})$.

Then 95% of all values of \bar{X} would lie in the interval $\mu \pm 1.960 \times \frac{\sigma}{\sqrt{n}}$.

That is, 5% of all values of \bar{X} would lie outside the interval $\mu \pm 1.960 \times \frac{\sigma}{\sqrt{n}}$.

- Let \bar{x} be the mean value of X for one of the samples taken.
 - If \bar{x} is *outside* the interval $\mu \pm 1.960 \times \frac{\sigma}{\sqrt{n}}$, then it is concluded that the sample mean \bar{x} *is significantly different* from the population mean μ at the 5% level of significance.
 - If \bar{x} is *inside* the interval $\mu \pm 1.960 \times \frac{\sigma}{\sqrt{n}}$, then it is concluded that the sample mean \bar{x} *is not significantly different* from the population mean μ at the 5% level of significance.
- This is represented visually in the diagram below.
The shaded region is called the *critical region*.
If \bar{x} falls inside this region, then it is significantly different from μ at the 5% level of significance.

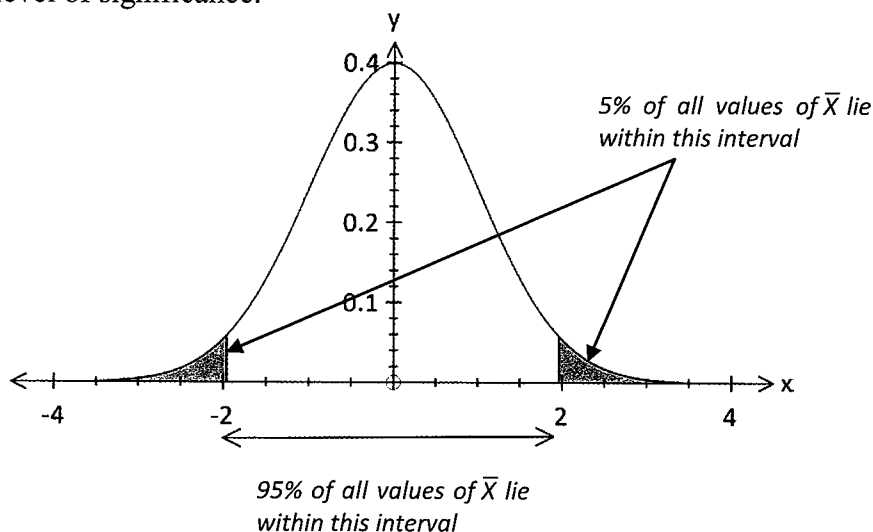

Example 20.11

The life of “Always Ready” laptop batteries is known to be normally distributed with mean 240 minutes and standard deviation 10 minutes. A random sample of 36 such batteries yielded a mean life of 230 minutes. Determine with reasons if the mean life of this sample is significantly different at a 10% level.

Solution:

Let X : Life of these laptop batteries. $\Rightarrow X \sim N(240, 10^2)$.

Then the sampling distribution $\bar{X} \sim N(240, \frac{10^2}{36})$.

10% of all values of \bar{X} will lie outside the interval $240 \pm 1.645 \times \frac{10}{\sqrt{36}} = 240 \pm 2.74$.

Clearly $\bar{X} = 230$ lies outside this interval.

Hence, the mean life of this sample is significantly different from the true mean at the 10% level.

Example 20.12

The adult length of a species of fish is known to be normally distributed with length 75 cm and standard deviation 15 cm. It is suspected that a random sample of 50 adult fish with mean length of 80 cm belong to this same species.

- Determine at a 1% level of significance if this suspicion is true. That is, determine if there is any significance difference between the mean length of this sample and the known mean length at the 1% level.
- Determine the level of significance for the difference between the mean length of this sample and the known length.

Solution:

(a) Let X : adult length of fish. $\Rightarrow X \sim N(75, 15^2)$.

Then the sampling distribution $\bar{X} \sim N(75, \frac{15^2}{50})$.

1% of all values of \bar{X} will lie outside the interval $75 \pm 2.576 \times \frac{15}{\sqrt{50}} = 75 \pm 5.46$.

Clearly $\bar{X} = 80$ lies inside this interval.

Hence, the mean life of this sample is not significantly different from the true mean at the 1% level. That is, at the 1% level of significance, there is no evidence to reject the suspicion.

- (b) The difference between the sample mean and the known mean = 5 cm.

Hence, $z_c \times \frac{15}{\sqrt{50}} = 5. \Rightarrow z_c = 2.357$. But $P(-2.357 \leq Z \leq 2.357) = 0.98158$.

Hence, the sample mean and the known mean is significantly different at the $(1 - 0.98158) \times 100 = 1.8\%$ level.

Exercise 20.3

1. The life of batteries for an *e*-book is advertised to be normally distributed with mean 1200 minutes and standard deviation 30 minutes. A random sample of 60 such *e*-books was tested under similar conditions and the sample yielded a mean life of 1190 minutes. Determine with reasons if the mean life of this sample is significantly different at a:
 - (a) 10% level
 - (b) 5% level
 - (c) 1% level.

2. The wing-span of a species of bird is known to be normally distributed with length 45 cm and standard deviation 5 cm. A random sample of 30 similar looking birds were trapped and the mean wing-span of the birds in this sample was measured to be 47 cm. Determine with reasons if the mean life of this sample is significantly different at a:
 - (a) 10% level
 - (b) 5% level
 - (c) 1% level.

3. The marks of a mathematics aptitude test are normally distributed with mean 62 and standard deviation 11. A group of 100 students had a mean mark of 65 for this test. Determine with reasons if the mean mark of this sample is significantly different at a:
 - (a) 2% level
 - (b) 8% level
 - (c) 10% level.

4. The amount of sugar in a 1 kg pack is normally distributed with mean 1000 g with standard deviation 1g. A sample of 200 such packs was tested and the mean weight of this sample is 999.9 g.
 - (a) Determine with reasons if the mean weight of this sample is significantly different at the 5% level.
 - (b) Determine the level of significance for the difference between the mean weight of this sample and the known mean weight.

5. The amount of berry juice in a 3 L bottle is normally distributed with mean 2999 mL with standard deviation 3 mL. A sample of n such bottles was tested and the mean amount of juice in this sample is 2999.8 mL.
 - (a) For $n = 50$, determine the level of significance for the difference between the mean amount of this sample and the known mean amount.
 - (b) Find n if this sample mean is to be significant at a (i) 5% level (ii) 10% level.

6. The amount of fresh milk in a 2 L container is normally distributed with mean μ and standard deviation. A sample of 1 000 such containers was tested and the mean amount of milk in this sample is 1998.5 mL with a sample standard deviation of 2 mL. A second sample of 80 containers had a mean of 1999 mL with a sample standard deviation of 2 mL. Use the mean and sample standard deviation of the first sample as estimates for μ and σ respectively.
 - (a) Determine the level of significance for the difference between the mean amount of milk in second sample and the known mean amount.
 - (b) How large should the next sample be if the sample mean of the next sample is to be significant at the (i) 1% level (ii) 5% level.

20.7 Simulating Confidence Intervals for the Population mean μ

- Different samples will yield different interval estimates for μ , for the same level of confidence. For example, 500 samples will yield 500 interval estimates for μ for a given confidence level. If the confidence level is 90%, then theoretically, 90% of the 500 intervals will contain the population mean μ . In this section, we will use a CAS calculator, to try to observe this phenomenon.

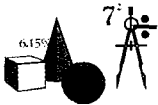

Hands On Task 20.2

(For Casio ClassPads Only)

In this task, we use a Casio ClassPad to simulate the construction of confidence intervals for the population mean μ based on a normal variable with mean μ and standard deviation σ .

- Create and save a new program "Sim05".

This program will:

- simulate b samples each containing n observations of a normal variable with parameters μ and σ .
- construct a $100c\%$ confidence interval for μ for each sample and display them on the screen.

```

Sim05  |N|
ClrText
Input n,"Size of Sample"
Input b,"No. of Samples"
Input  $\mu$ ,"Mean","Population Parameters"
Input  $\sigma$ ,"Std Dev","Population Parameters"
Input c,"Level 0<c<1","Confidence"
invNormCDF("C",c,1,0) $\Rightarrow$ d
Print "mean="
Locate 30,1, $\mu$ 
For 1 $\Rightarrow$ i To b
  randNorm( $\sigma$ , $\mu$ ,n) $\Rightarrow$ x
  [mean(x)+d $\times$  $\sigma$ / $\sqrt{n}$ ,mean(x)-d $\times$  $\sigma$ / $\sqrt{n}$ ] $\Rightarrow$ y
  Print y
Next

```

- The accompanying screen dump shows a simulation of 10 samples of 30 observations each of a normal variable with $\mu = 100$ and $\sigma = 20$. Ten 90% confidence intervals are displayed. In this simulation, nine of the intervals actually contain the mean $\mu = 100$. This need not necessarily be true all the time.

```

mean=100
[[95.00807575,107.0203882]]
[[96.40264647,108.4149589]]
[[91.61087156,103.623184]]
[[82.81155451,94.82386698]]
[[91.12108119,103.1333937]]
[[94.44897414,106.4612866]]
[[98.49315633,110.5054688]]
[[89.84569729,101.8580098]]
[[97.03445731,109.0467698]]
[[89.63977771,101.6520902]]

```

- Explore the phenomenon that $100c\%$ of the confidence intervals will actually contain the population mean μ .

Answers

Exercise 1.1

- (a) $2, \pi/3$ (b) $2, -2\pi/3$ (c) $2, -\pi/6$
(d) $2\sqrt{2}, 3\pi/4$ (e) $4, \pi/2$ (f) $6, -\pi/2$
- (a) $\sqrt{5} \operatorname{cis}(1.107)$ (b) $5 \operatorname{cis}(2.21)$
(c) $\operatorname{cis}(0.93)$ (d) $2 \operatorname{cis}(\pi/6)$ (e) $4 \operatorname{cis}(0)$
(f) $3 \operatorname{cis}(-\pi/2)$
- (a) $2i$ (b) $(3\sqrt{2}/2) - (3\sqrt{2}/2)i$
(c) $-\sqrt{3} + i$ (d) $-3i$ (e) $-1 + i$
(f) $-(5\sqrt{3}/2) + (5/2)i$
- (a) $2 - 3i, \sqrt{13} \operatorname{cis}(-0.98)$
(b) $-1 + 4i, \sqrt{17} \operatorname{cis}(1.82)$
(c) $3 + 5i, \sqrt{34} \operatorname{cis}(1.03)$
- (a) $a\sqrt{5}, 2$ (b) $\sqrt{(a^2 + 1)}, -a$
(c) $\sqrt{(a + 4)}, -2/a$ (d) $(1/a)\sqrt{(a + 1)}, a$

Exercise 1.2

- (a) $6 \operatorname{cis}(7\pi/12)$ (b) $9 \operatorname{cis}(-5\pi/6)$
(c) $20 \operatorname{cis}(-7\pi/12)$ (d) $10 \operatorname{cis}(5\pi/6)$
(e) $32 \operatorname{cis}(-3\pi/4)$ (f) $81 \operatorname{cis}(-2\pi/3)$
(g) $(1/81) \operatorname{cis}(2\pi/3)$ (h) $(1/64) \operatorname{cis}(\pi/2)$
- (a) $2 \operatorname{cis}(\pi/12)$ (b) $2 \operatorname{cis}(-\pi/12)$
(c) $2 \operatorname{cis}(-5\pi/6)$ (d) $\operatorname{cis}(\pi/2)$
(e) $\operatorname{cis}(2\pi/3)$ (f) $(1/3) \operatorname{cis}(-\pi/2)$
(g) $32 \operatorname{cis}(\pi/2)$ (h) $80 \operatorname{cis}(\pi)$
- (a) $1 - \sqrt{3}i, (1/4) - (\sqrt{3}/4)i$
(b) $(3\sqrt{2}/2) + (3\sqrt{2}/2)i, (\sqrt{2}/6) + (\sqrt{2}/6)i$
(c) $-2\sqrt{2} - 2\sqrt{2}i, (-\sqrt{2}/8) - (\sqrt{2}/8)i$
(d) $(5/2)(-\sqrt{3} + i), (-\sqrt{3}/10) + (1/10)i$
(e) $2, 1/2$ (f) $(1/2)i, 2i$
- (a) $8 \operatorname{cis}(-\pi/2), -8i$
(b) $4\sqrt{2} \operatorname{cis}(3\pi/4), -4 + 4i$
(c) $32 \operatorname{cis}(-\pi/3), 16 - 16\sqrt{3}i$
(d) $64 \operatorname{cis}(\pi), -64$
(e) $(1/64) \operatorname{cis}(0), 1/64$
(f) $(1/64) \operatorname{cis}(\pi), -1/64$
(g) $(1/32) \operatorname{cis}(5\pi/6), -(\sqrt{3})/64 + i/64$
(h) $(1/16) \operatorname{cis}(2\pi/3), -1/32 + (i\sqrt{3})/32$
- (a) $4\sqrt{2} \operatorname{cis}(-\pi/4), 4 - 4i$
(b) $4 \operatorname{cis}(\pi), -4$
(c) $2 \operatorname{cis}(2\pi/3), -1 + \sqrt{3}i$
(d) $27 \operatorname{cis}(\pi/2), 27i$
(e) $(1/2) \operatorname{cis}(-\pi/2), (-1/2)i$
(f) $(4/9) \operatorname{cis}(-5\pi/6), (2\sqrt{3}/9) - (2/9)i$
(g) $(ab/9) \operatorname{cis}(-\pi/4); (ab\sqrt{2})/18 - [(ab\sqrt{2})/18]i$
(h) $|a(5b)| \operatorname{cis}(3\pi/4);$
 $(-|a|\sqrt{2})/(10|b|) + [(|a|\sqrt{2})/(10|b|)]i$
- (a) $(2\sqrt{3}/3) \operatorname{cis}(\pi/6), 1 + (\sqrt{3}/3)i$
(b) $(16/9) \operatorname{cis}(-5\pi/6), (-8\sqrt{3}/9) - (8/9)i$
(c) $(8\sqrt{3}/3) \operatorname{cis}(-5\pi/6), -4 - (i4\sqrt{3})/3$
(d) $(1/16) \operatorname{cis}(\pi), -1/16$
(e) $(9\sqrt{3}/2) \operatorname{cis}(\pi/6), (27/4) + (9\sqrt{3}/4)i$

- (f) $(9\sqrt{3}/2) \operatorname{cis}(2\pi/3), (-9\sqrt{3}/4) + (27/4)i$
(g) $(1024/27) \operatorname{cis}(0), 1024/27$
(h) $(1024/27)^k \operatorname{cis}(0), (1024/27)^k$
- (a) $\bar{w} = a \operatorname{cis}(-\alpha), \bar{z} = b \operatorname{cis}(-\beta)$

Exercise 1.3

1.

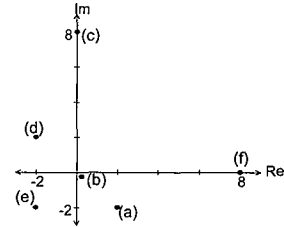

2.

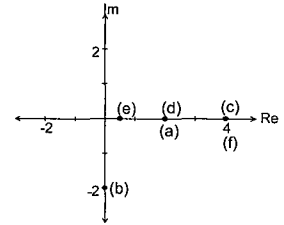

3.

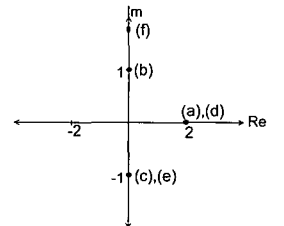

- (a) $r \operatorname{cis}(\theta - \pi)$ (b) $r \operatorname{cis}(-\theta)$
(c) $r \operatorname{cis}(\theta - \pi/2)$ (d) $r \operatorname{cis}(2\theta)$
(e) r (f) $2r \cos \theta$
(g) $(1/r) \operatorname{cis}(-\theta)$ (h) $(1/r) \operatorname{cis}(\pi/2 - \theta)$
(i) $r \operatorname{cis}(\pi/2 - \theta)$ (j) $r \operatorname{cis}(2\theta - \pi)$
(k) $1/r$ (l) $2r \sin \theta \operatorname{cis}(\pi/2)$

5.

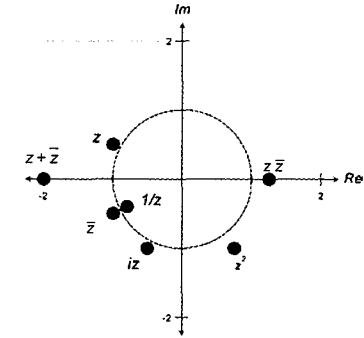

6.

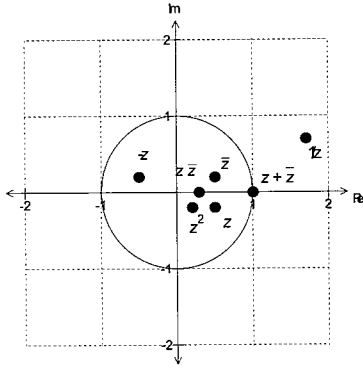

7.

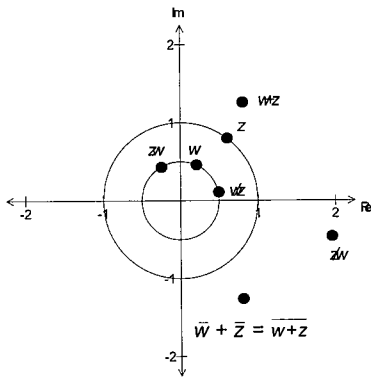

8.

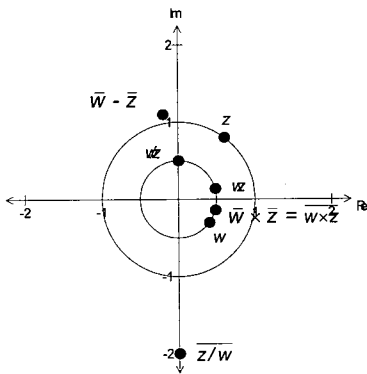

9.

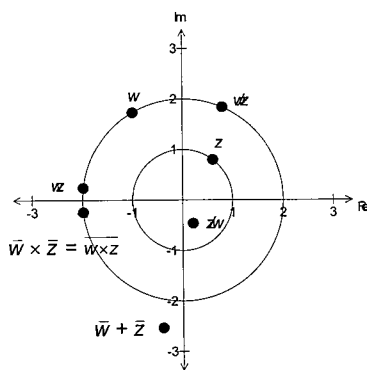

Exercise 1.4

1. (a)

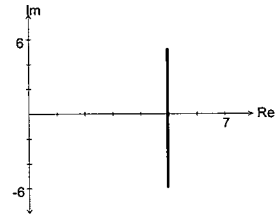

(b)

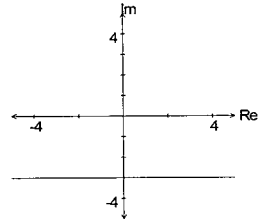

(c)

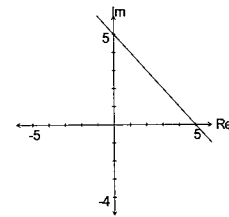

(d)

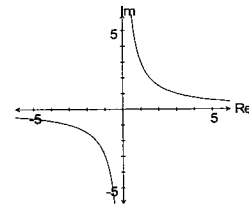

(e)

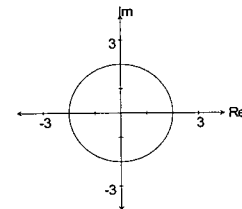

(f)

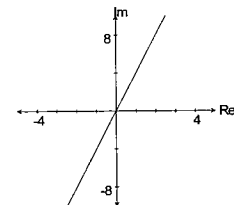

1. (g)

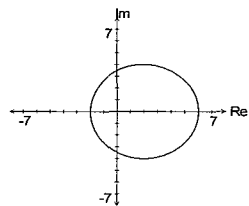

(h)

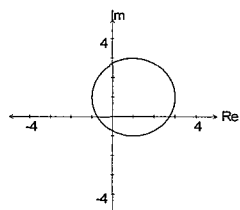

(i)

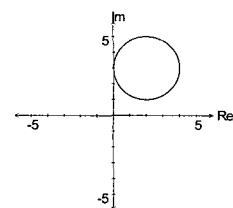

(j)

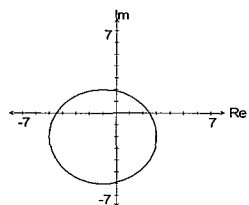

(k)

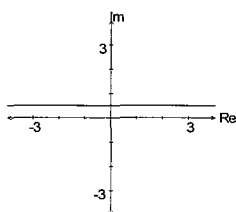

(l)

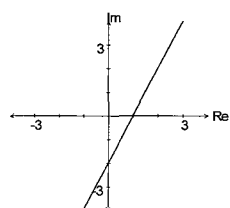

1. (m)

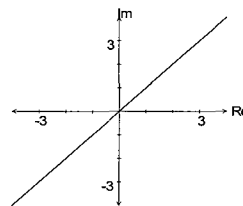

(n)

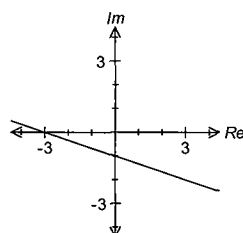

2. (a) $x = 5$ (b) $y = -3$ (c) $x + y = 5$
 (d) $xy = 3$ (e) $x^2 + y^2 = 4$ (f) $y = 4x$
 (g) $(x - 2)^2 + y^2 = 16$
 (h) $(x - 1)^2 + (y - 1)^2 = 4$
 (i) $(x - 2)^2 + (y - 3)^2 = 4$
 (j) $(x + 1)^2 + (y + 2)^2 = 16$
 (k) $y = 1/2$ (l) $y = x - 2$
 (m) $y = x$ (n) $y = (-x/3) - 1$

3. (a)

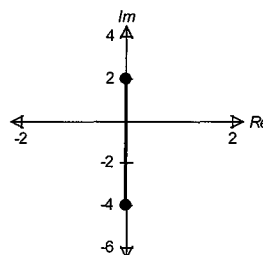

(b)

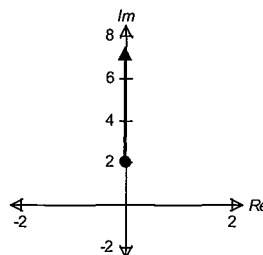

(c)

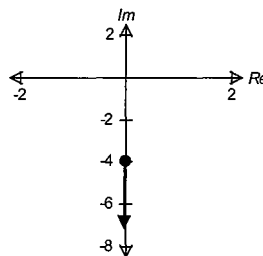

4. (a)

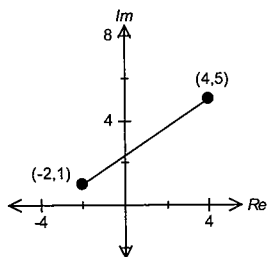

(b)

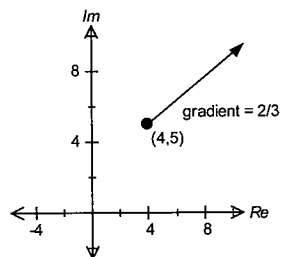

(c)

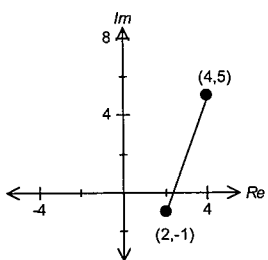

5. (a)

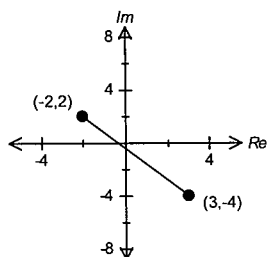

(b)

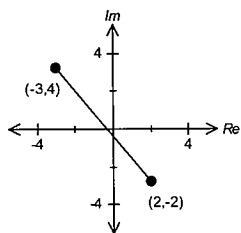

(c)

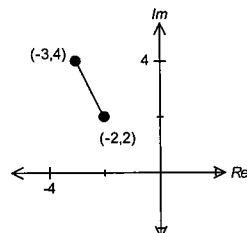

6. (a)

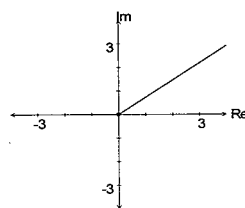

(b)

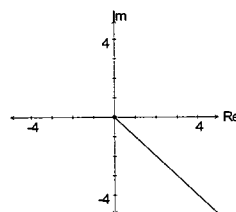

(c)

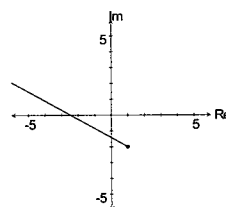

(d)

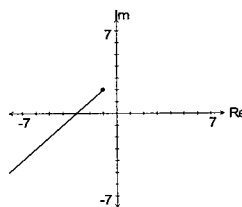

(e)

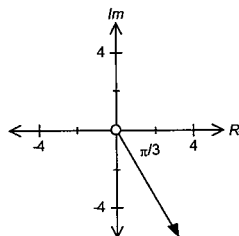

(f)

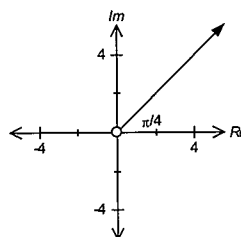

7. (a)

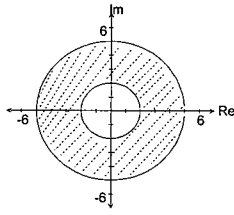

(b)

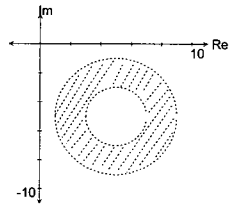

(c)

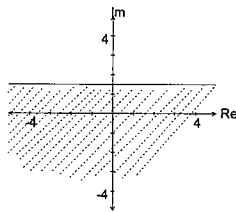

(d)

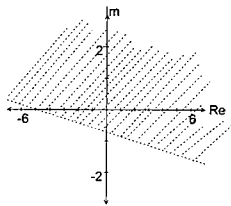

(e)

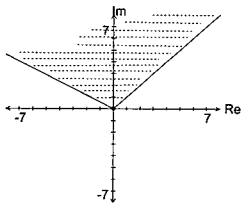

(f)

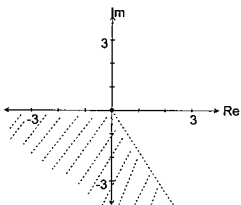

(g)

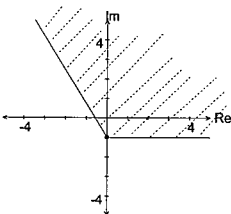

7. (h)

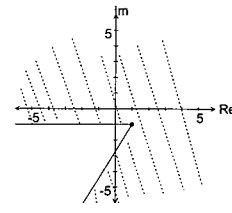

8. (a)

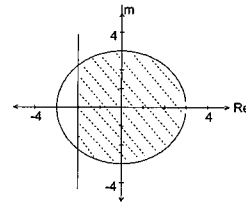

(b)

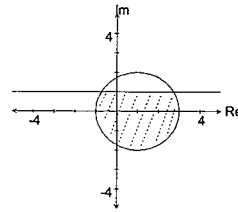

(c)

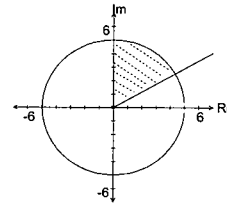

(d)

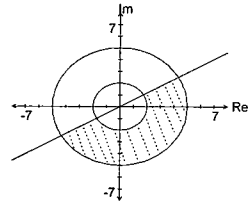

(e)

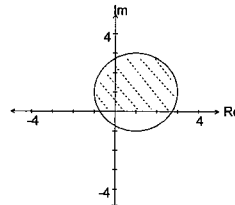

(f)

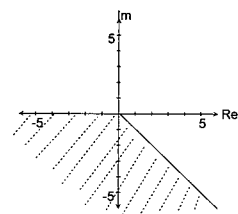

9. (a) $x^2 + y^2 = 1$ or $y = 0$

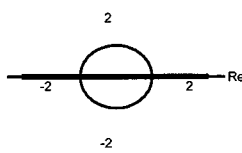

(b) $x^2 + y^2 = 1$ or $x = 0$

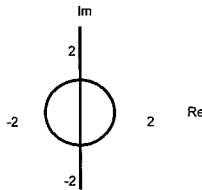

(c) $x^2 + y^2 = 4$ or $y = 0$

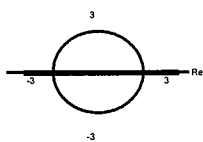

(d) $(x-1)^2 + (y+1)^2 = 2$ except the point (2,0)

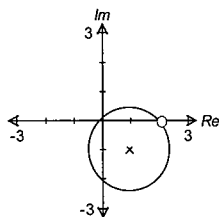

(e) $5x - 2y + 6 = 0$

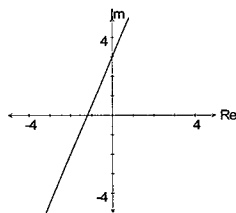

(f) $x^2 + (y - 1/2)^2 = 1/4$

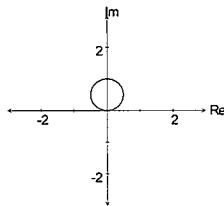

(g) $y = 0$

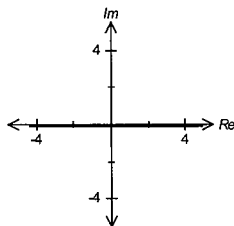

9. (h) $x = 0$

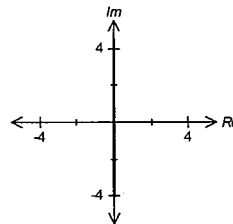

(i) $(x + 4/3)^2 + (y + 1/3)^2 = (2\sqrt{2}/3)^2$

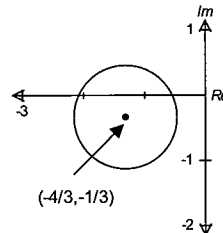

(j) $(x + 5/4)^2 + (y - 19/8)^2 = 117/64$

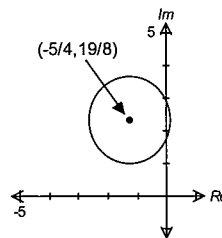

10. (a) $\min \sqrt{2} - 1, \max \sqrt{2} + 1$
 (b) $\min -\pi/2 \text{ rad}, \max 0 \text{ rad}$
 11. (a) $0 < |z| \leq 10$
 (b) $-0.64 < \arg(z) \leq 2.50 \text{ rad}$
 12. (a) $0 < |z| \leq \sqrt{2}$
 (b) $0 < \arg(z) \leq \pi/4$
 13. (a) $\min 1, \max 2 + \sqrt{2}$
 (b) $\min -1.25 \text{ rad}, \max \pi/4 \text{ rad}$
 14. (a) $|z - 5| = |z - 5i|$
 (b) $|z - (1 + i)| \leq 1$
 (c) $-\pi/4 \leq \arg(z) \leq \pi/4$
 (d) $|z - 2| \leq 3$ and $|z - 6| \leq 3$
 (e) $|z - (-3 + 2i)| + |z - (7 + 2i)| = |(7 + 2i) - (-3 + 2i)|$
 (f) $|z - (2 + 2i)| \leq 8$ and $\pi/4 \leq \arg(z) \leq \pi/2$

Exercise 2.1

1. (a) $\text{cis}(\pi/3), \text{cis}(\pi), \text{cis}(-\pi/3)$
 (b) $2 \text{cis}(\pi/3), 2 \text{cis}(\pi), 2 \text{cis}(-\pi/3)$
 (c) $\sqrt{2} \text{cis}(\pi/4), \sqrt{2} \text{cis}(3\pi/4), \sqrt{2} \text{cis}(-3\pi/4), \sqrt{2} \text{cis}(-\pi/4)$
 (d) $\text{cis}(0), \text{cis}(2\pi/5), \text{cis}(4\pi/5), \text{cis}(-4\pi/5), \text{cis}(-2\pi/5)$
 (e) $2 \text{cis}(0), 2 \text{cis}(2\pi/5), 2 \text{cis}(4\pi/5), 2 \text{cis}(-4\pi/5), 2 \text{cis}(-2\pi/5)$
 (f) $2 \text{cis}(0), 2 \text{cis}(\pi/3), 2 \text{cis}(2\pi/3), 2 \text{cis}(\pi), 2 \text{cis}(-2\pi/3), 2 \text{cis}(-\pi/3)$
 2. (a) $0.9239 + 0.3827i, -0.9239 - 0.3827i, -0.3827 + 0.9239i, 0.3827 - 0.9239i$
 (b) $\pm 0.9511 - 0.3090i, \pm 0.5878 + 0.8090i, -i$
 (c) $1.0696 + 0.2127i, -1.0696 - 0.2127i, -0.2127 + 1.0696i, 0.2127 - 1.0696i$

2. (d) $1.1236 + 0.2388i, 0.1201 + 1.1424i,$
 $-1.0494 + 0.4672i, -0.7686 - 0.8536i$
 $0.5743 - 0.9948i$
 (e) $1.0548 - 0.3839i, 0.8599 + 0.7215i,$
 $-0.1949 + 1.1054i, -1.0548 + 0.3839i,$
 $-0.8599 - 0.7215i, 0.1949 - 1.1054i$
 (f) $-1.5, 0.75 \pm 1.2990i$
4. $\pm 1, (\pm 0.5 \pm 0.8660i)$
5. $w = (-1/2) + (\sqrt{3}/2)i, w^2 = (-1/2) - (\sqrt{3}/2)i,$
 $w^3 = 1; z = 1$
6. $3 \operatorname{cis}(\pi), 3 \operatorname{cis}(3\pi/5), 3 \operatorname{cis}(-3\pi/5), 3 \operatorname{cis}(\pi/5),$
 $3 \operatorname{cis}(-\pi/5); z^5 = -243$
7. $2 \operatorname{cis}(\pi/3), 2 \operatorname{cis}(2\pi/3), 2 \operatorname{cis}(\pi), 2 \operatorname{cis}(-2\pi/3),$
 $2 \operatorname{cis}(-\pi/3), 2 \operatorname{cis}(0); z^6 = 64$
8. $\sqrt{2} \operatorname{cis}(-\pi/4), \sqrt{2} \operatorname{cis}(0), \sqrt{2} \operatorname{cis}(\pi/4),$
 $\sqrt{2} \operatorname{cis}(\pi/2), \sqrt{2} \operatorname{cis}(3\pi/4), \sqrt{2} \operatorname{cis}(\pi),$
 $\sqrt{2} \operatorname{cis}(-\pi/2), \sqrt{2} \operatorname{cis}(-3\pi/4); z^8 = 16$
9. $n = 5; \operatorname{cis}(\pm\pi/5), \operatorname{cis}(\pm3\pi/5), \operatorname{cis}(\pi)$
10. (a) $-1/2 \pm (\sqrt{3}/2)i, 1$
 (b) $\pm i, \pm 2i, \pm 1$
 (c) $-1/2 \pm (\sqrt{3}/2)i, \pm(\sqrt{3})/2 - (1/2)i, i$
 (d) $\pm(\sqrt{3}/2) + (1/2)i, \pm\sqrt{3} - i, -i, 2i$

Exercise 2.2

3. $\sin(\pi/6)$ repeated, $\sin(3\pi/2)$
4. $\cos(\pi/9), \cos(5\pi/9), \cos(7\pi/9)$
5. $\cos(6\theta) = 32 \cos^2(\theta) - 48 \cos^4(\theta)$
 $+ 18 \cos^6(\theta) - 1$
 (a) $\cos(\pi/12), \cos(\pi/4), \cos(5\pi/12),$
 $\cos(7\pi/12), \cos(3\pi/4), \cos(11\pi/12)$
 (b) $\cos^2(\pi/12), \cos^2(\pi/4), \cos^2(5\pi/12)$
6. (a) $\cos(5\theta) = 16 \cos^5(\theta) - 20 \cos^3(\theta) + 5 \cos(\theta)$
 (b) $a = 16, b = -4, c = -4, d = 1$
 (c) $\cos(2\pi/5)$ repeated, $\cos(4\pi/5)$ repeated

Exercise 2.3

1. (a) $2e^{i\pi}$ (b) $5e^{i3\pi/4}$
 (c) $3e^{-i\pi/6}$ (d) $\sqrt{2}e^{-i2\pi/3}$
2. (a) e^0 (b) $e^{i\pi/2}$ (c) $2e^{i\pi/3}$
 (d) $2\sqrt{2}e^{-i3\pi/4}$ (e) $2\sqrt{3}e^{-i\pi/6}$
3. (a) $\operatorname{cis}(\pi/6)$ (b) $\operatorname{cis}(-5\pi/6)$
 (c) $e \operatorname{cis}(-\pi/4)$ (d) $(1/e^2) \operatorname{cis}(\pi/3)$
4. (a) $(-1/2) + i(\sqrt{3})/2$
 (b) $(-\sqrt{2})/2 + i(\sqrt{2})/2$
 (c) $1/(2e) - i(\sqrt{3})/(2e)$
 (d) $(-e^2\sqrt{3})/2 + i(e^2)/2$
5. (a) $4e^{-i\pi/3}$ (b) $2\sqrt{2}e^{i7\pi/12}$
 (c) $\sqrt{2}e^{-i3\pi/4}$ (d) $2e^{i\pi/6}$

5. (e) 2 (f) $2e^{i\pi/2}$
 (g) $2\sqrt{2}e^{-i7\pi/12}$ (h) $2\sqrt{2}e^{-i7\pi/12}$
6. (a) $12e^{i2\pi/3}$ (b) $12e^{i2\pi/3}$
 (c) $\frac{\sqrt{2}}{4}e^{i\pi/4}$ (d) $\frac{\sqrt{2}}{4}e^{i\pi/4}$
 (e) $\sqrt{\frac{3}{2}}e^{i7\pi/12}$ (f) $\sqrt{\frac{3}{2}}e^{i7\pi/12}$
7. (a) $\frac{\sqrt{2}}{2} \operatorname{cis}(\frac{\pi}{6})$ (b) $2\sqrt{2} \operatorname{cis}(\frac{5\pi}{6})$
 (c) $\frac{\sqrt{2}}{2} \operatorname{cis}(-\frac{\pi}{6})$ (d) $\frac{\sqrt{2}}{2} \operatorname{cis}(-\frac{\pi}{6})$
 (e) $2\sqrt{2} \operatorname{cis}(-\frac{5\pi}{6})$ (f) $2\sqrt{2} \operatorname{cis}(\frac{5\pi}{6})$
12. (a) $x = 0, y = \pi$ (b) $x = \ln 2, y = \pi$
 (c) $x = \ln 2, y = 0$ (d) $x = 0, y = \pi/2$
 (e) $x = \ln \sqrt{2}, y = \pi/4$
13. (a) $a = 0, b = \pi$ (b) $a = \ln 2, b = \pi$
 (c) $a = \ln 3, b = \pi$
14. $a = \ln k^2, y = \pi$
15. $\operatorname{Max} \operatorname{Re}(z) = 2, \operatorname{Min} \operatorname{Im}(z) = -2$

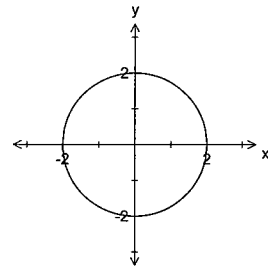

16. $\operatorname{Min} \operatorname{Re}(z) = -1/e, \operatorname{Max} \operatorname{Im}(z) = 1/e$

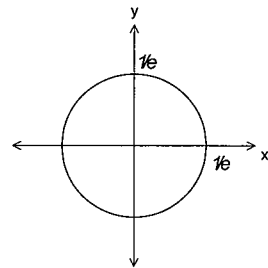

Exercise 3.1

1. $a = 6, b = -4$ 2. $k = -1$
 3. $a = 2, b = 0, c = 5$ 4. $a = -3, b = 0, c = 7$
 5. (a) $(x+1)(x+2)(x+3)(x+4)$
 (b) $(x+1)(x+2)$
 (c) $(x-1)(x-2)(x+3)$
 (d) $(x+1)(x-2)(2x-1)(2x+1)$
 (e) $(x-1)(2x+1)(x^2+1)$
 (f) $(x-1)(x-2)(x+4)$

6. $(x^3 + 3)(x - 2)(x - 1)(x + 1)$

7. (a)

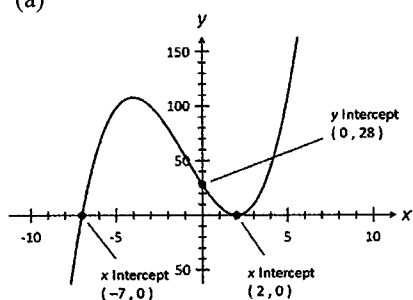

(b)

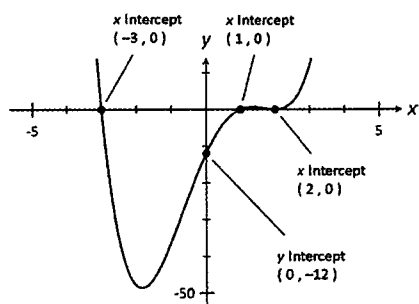

(c)

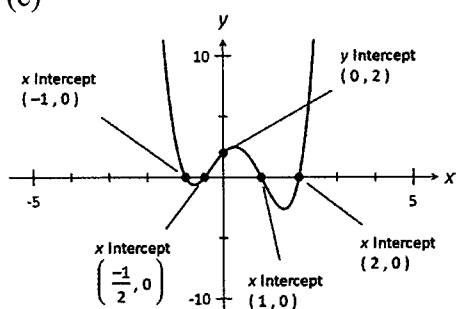

(d)

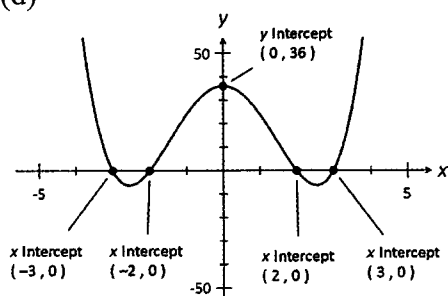

8. (a) $-1, -2$ (b) $-1, 1$
 (c) $-1, 0, 1, 1/3, 2$ (d) $-1, -1/3, 1/2, 0, 1$
 (e) $\pm 2, 1 \pm \sqrt{2}$ (f) $-1, 2$
9. $-1, 2/3, 1/2$
 (a) $-1/2, 1/3, 1/4$ (b) $\pm \sqrt{2/3}, \pm \sqrt{1/2}$
 (c) $-2/3, -1/2, 1$ (d) $-1, 3/2, 2$
10. $-3, -1/2, 2$
 (a) $-2, 1/2, 3$ (b) $\pm \sqrt{2}$
 (c) $-2, -1/3, 1/2$ (d) $-1/2, 1/3, 2$

Exercise 3.2

1. (a) $(x^2 - 2x + 8), -23$; $x, 8x - 7$
 (b) $3x^2/2 - 7x/4 - 39/8, 57/8$; $3x - 2, -16x + 16$

1. (c) $-2x^2 + 4x - 7/2, 17/2$; $-2x + 4, -9x + 9$
 (d) $6x^2 + 7x + 16x + 27, 64$
 $6x^2 - 5x + 26, -25x + 114$
 $3x - 4, 3x^2 + 5x + 2$
2. $p = 1, q = 3$ 3. $p = 12/5, q = -24/5$
 4. $p = -5, q = 7$ 5. $p = 3, q = 5$
 6. $a = 1, b = -5$ 7. $a = -35, b = -23$
 8. $a = 1, b = -2$
 9. $p = 9, q = -2, r = -11$
 10. $p = -8, q = 3, r = 9$
 11. $a = 3, b = 4$
 12. $a = 6, b = -7$
 13. (b) $a = -3, b = -2$ (c) $5(2x + 3)$
 14. $a = 2, b = 1, c = 3$; 103

Exercise 3.3

1. (a) $(z - i)(z + i)(z + 2)$
 (b) $(z - 2i)(z + 2i)(z + 2)$
 (c) $(2z + i)(2z - i)(z - 1)$
 (d) $(z - (1 - i))(z - (1 + i))(z + 4)$
2. $a = -4, b = 16$; $(z - 4i)(z + 4i)(z - 4)$
 3. $a = -2, b = 4$; $(z - 1 - i)(z - 1 + i)(z + 2)$
 4. $a = 6, b = -15$; $1 \pm 2i, \pm \sqrt{3}$
 5. $a = 16, b = 4$; $-2 \pm i, \pm i/2$
 6. $a = 9, b = 2$; $-1 \pm \sqrt{2}i, \pm i/3$
7. (a) $\pm 1, \pm i\sqrt{2}$ (b) $-1, 2, -1 \pm i$
 (c) $-1, 3, 1 \pm i\sqrt{2}$ (d) $\pm 2i, 2 \pm i$
8. (a) $1, \pm (\sqrt{2}/2) \pm i(\sqrt{2}/2)$
 (b) $\pm 1, \pm (\sqrt{2}/2) \pm i(\sqrt{2}/2)$
 (c) $\pm 1, \pm 1/2 \pm i(\sqrt{3})/2$
 (d) $\pm 1, \pm 1/2 \pm i(\sqrt{3})/2$
9. $a = 6, b = 0, c = 1$ 10. $a = 4, b = 4, c = 4$

Exercise 4.1

1. (a) Not an onto function.
 (b) Not an onto function.
 (c) Not an onto function.
 (d) Is an onto function.
2. (a) Many to one function.
 (b) Many to one function.
 (c) One to one function.
3. (a) One to one function.
 (b) Many to one function.
 (c) One to one function.
 (d) Many to one function.
 (e) One to one function.
 (f) Many to one function.
 (g) One to one function.
 (h) Many to one function.
 (i) Many to one function.
 (j) Many to one function.
4. (a) $(-\infty, 3/2]$ or $[3/2, \infty)$
 (b) $(-\infty, -2]$ or $[-2, \infty)$
 (c) $(-\infty, -1)$ or $(-1, \infty)$
 (d) \mathbb{R}
 (e) $(-\infty, 2]$ or $[2, \infty)$
 (f) $(-\infty, 5/2]$ or $[5/2, \infty)$

4. (g) $[-7, -2]$ or $[-2, 3]$ (h) $[-2, 2]$ or $[2, 6]$
 (i) $[-2, 0]$ or $[0, 2]$ (j) $(-\infty, 0]$ or $[2, \infty)$
 5. (a) $[-\pi/4, \pi/4]$ (b) $[0, 2\pi]$
 (c) $[-3\pi/4, \pi/4]$ (d) $[0, \pi/2]$
 (e) $[-\pi, 0) \cup (0, \pi]$
 (f) $[-\pi/2 - \tan^{-1}(4/3), \pi/2 - \tan^{-1}(4/3)]$

Exercise 4.2

1. (a) Yes (b) No
 (c) Yes (d) No
 2. (a) Yes (b) Yes
 (c) Yes (d) Yes
 3. (a) Yes (b) No
 (c) Yes (d) No
 4. (a) Yes (b) No
 (c) Yes (d) No
 5. (a) x^2 (b) $(x-3)^2 + 3$
 (c) $x-6$ (d) $(x+3)^2 + 3$
 6. (a) $1/x^2$ (b) $1/(x+1)^2 - 1$
 (c) $(x+1)/(x+2)$ (d) $(x-1)^2 - 1$
 7. (a) e^{1+2x} (b) $1+2e^x$
 (c) e^{e^x} (c) $3+4x$
 8. (a) $1+x$ (b) $1/(2-x)$
 (c) $(x-1)/x$ (d) $x/(2x+1)$
 9. (a) Domain for f : \mathbb{R} , Range for f : \mathbb{R}
 Domain for g : $\mathbb{R} - \{0\}$
 Range for g : $\mathbb{R} - \{0\}$
 (b) $\mathbb{R} - \{5\}$
 (c) $1/(5-x)$; $\mathbb{R} - \{5\}$, $\mathbb{R} - \{0\}$.
 10. (a) Domain for f : \mathbb{R} , Range for f : $[-5, \infty)$
 Domain for g : $[-1, \infty)$
 Range for g : $[0, \infty)$
 (b) $[-1, \infty)$
 (c) $x-4$; $[-1, \infty)$, $[-5, \infty)$
 11. $(1, \infty)$; x , $(1, \infty)$, $(1, \infty)$
 12. $(-\infty, 1] \cup [1, \infty)$; $1 + |x|$, $(-\infty, -1] \cup [1, \infty)$,
 $[2, \infty)$
 13. (a) $\ln(1 + \sin x)$; Not a function.
 (b) $\sin(\ln x) + 1$; Is a function. \mathbb{R}^+ , $[0, 2]$
 14. (a) 5^{25-x} ; Is a function. $(-\infty, 25]$, \mathbb{R}^+
 (b) $25-5^x$; Not a function.
 15. $g(x) = x+5$ 16. $g(x) = 1/(x-2)$
 17. $g(x) = -1/[2(x+1)]$ 18. $f(x) = 5-x$
 19. $f(x) = 2x-3$ 20. $g(x) = (x-3)^2 + 1$
 21. $g(x) = (x-1)/(3x-1)$

Exercise 4.3

1. (a) Yes; domain \mathbb{R}^+ , range \mathbb{R}
 (b) No, $[-1, \infty)$ or $(-\infty, -1]$;
 domain \mathbb{R}_0^+ , range $[-1, \infty)$ or $(-\infty, -1]$

1. (c) No, $[-1, \infty)$ or $(-\infty, -1]$;
 domain $(-\infty, 1]$, range $[-1, \infty)$ or $(-\infty, -1]$
 (d) Yes; domain $[0, \infty)$ range $[1, \infty)$
 2. (a) Yes (b) No
 (c) No (d) Yes
 (e) Yes (f) Yes
 (g) Yes (h) Yes
 (i) No (j) No
 3. (a) $(x-3)/2$ (b) $-(4+x)/5$
 (c) $4 \pm \sqrt{x}$ (d) $2 \pm \sqrt[1/3]{1-x}$
 (e) $(-5 \pm \sqrt{x})/2$ (f) x^x
 (g) $[\ln(x)-1]/2$ (h) $(e^x-1)/2$
 (i) $(x-1)/x$ (j) $(1-x)/(x+1)$
 (k) x^2-1 (l) $(1+x)^2/x$
 4. (a) $x \geq -4$ or $x \leq -4$;
 $f^{-1}(x) = -4 + \sqrt{x}$, domain $x \geq 0$,
 range $y \geq -4$;
 $f^{-1}(x) = -4 - \sqrt{x}$, domain $x \geq 0$,
 range $y \leq -4$
 (b) $x \geq 2$ or $x \leq 2$;
 $f^{-1}(x) = 2 + \sqrt{x-1}$, domain $x \geq 1$,
 range $y \geq 2$
 $f^{-1}(x) = 2 - \sqrt{x-1}$, domain $x \geq 1$,
 range $y \leq 2$
 (c) $x \geq 0$ or $x \leq 0$;
 $f^{-1}(x) = \sqrt{x+1}$, domain $x \geq -1$,
 range $y \geq 0$
 $f^{-1}(x) = -\sqrt{x+1}$, domain $x \geq -1$,
 range $y \leq 0$
 (d) $x \geq -1$ or $x \leq -1$;
 $f^{-1}(x) = -1 + \sqrt{x-1}$, domain $x \geq 1$,
 range $y \geq -1$
 $f^{-1}(x) = -1 - \sqrt{x-1}$, domain $x \geq 1$,
 range $y \leq -1$
 (e) $x \geq 0$ or $x \leq 0$;
 $f^{-1}(x) = \sqrt{[(1/x)-1]}$, domain $0 < x \leq 1$,
 range $y \geq 0$
 $f^{-1}(x) = -1\sqrt{[(1/x)-1]}$, domain $0 < x \leq 1$,
 range $y \leq 0$
 (f) $x > 1$ or $x < 1$;
 $f^{-1}(x) = 1 + \sqrt{1/x}$, domain $x > 0$,
 range $y > 1$
 $f^{-1}(x) = 1 - \sqrt{1/x}$, domain $x > 0$,
 range $y < 1$
 (g) $-\pi/2 \leq x \leq \pi/2$;
 $f^{-1}(x) = \sin^{-1} x$, domain $-1 \leq x \leq 1$,
 range $-\pi/2 \leq y \leq \pi/2$
 (h) $0 \leq x \leq \pi/2$;
 $f^{-1}(x) = (\cos^{-1} x)/2$, domain $-1 \leq x \leq 1$,
 range $0 \leq y \leq \pi/2$

4. (i) $-\pi < x < \pi$;
 $f^{-1}(x) = \tan^{-1} x$, domain \mathbb{R} ,
 range $-\pi < y < \pi$
5. (a) $\sqrt{1 - e^x}$; $(-\infty, 0]$, $[0, 1]$
 (b) $e^{\sqrt{1-x}}$; $(-\infty, 1]$, $[1, \infty)$
 (c) $\ln(1-x)$; $1 - (\ln x)^2$
6. (a) $(x-1)/2$; $4 - 1/x$; $(3 - 1/x)/2$
7. (a) $x^2 - 1$; $1/x - 1$; $1/(x^2 - 1) - 1$
8. (a) Domain of f : \mathbb{R}_0^+ . Domain of g : \mathbb{R}_0^+ .
 (b) Domain of f : \mathbb{R}_0^+ . Domain of g : \mathbb{R}_0^+ .
9. (a) Domain of f : $(-\infty, 1]$.
 Domain of g : \mathbb{R}_0^+ .
 (b) Domain of f : $(-\infty, 1]$.
 Domain of g : \mathbb{R}_0^+ .
10. Domain of f : $(-1, \infty)$. Domain of g : $(0, \infty)$.

Exercise 5.1

1. (a)

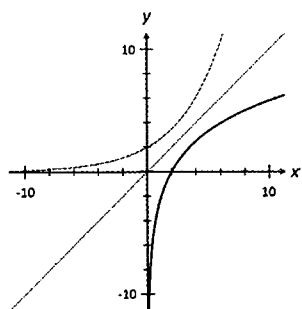

(b)

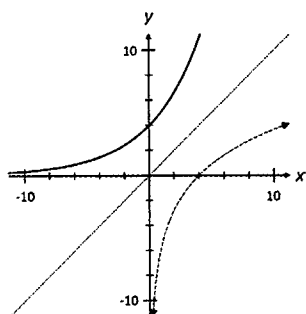

(c)

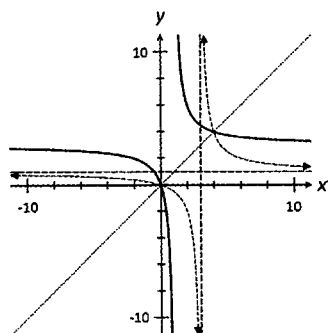

1. (d)

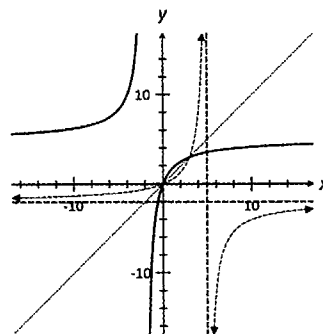

2. (a)

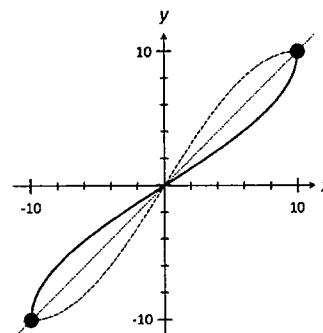

(b)

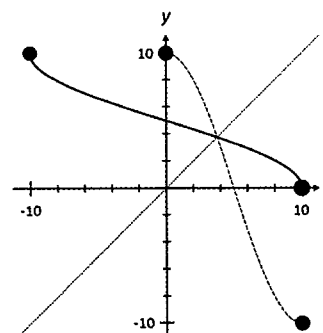

(c)

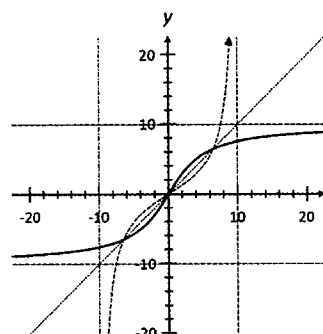

(d)

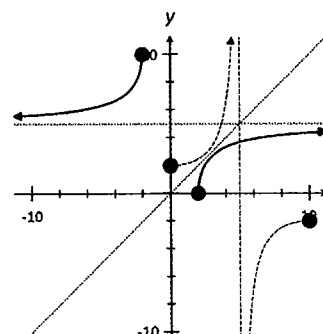

3. (a)

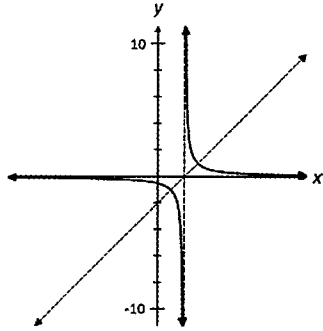

(b)

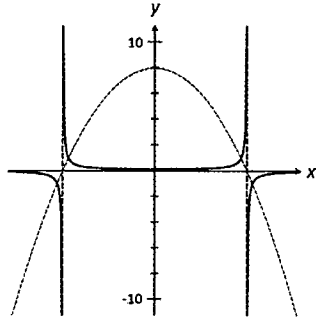

(c)

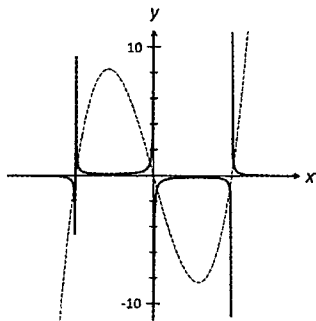

(d)

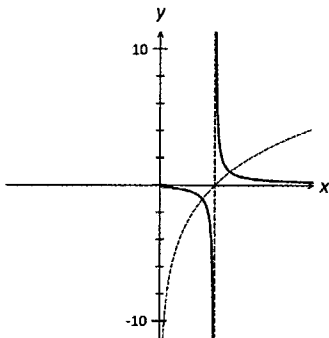

4. (a)

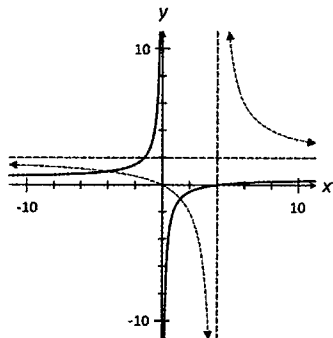

4. (b)

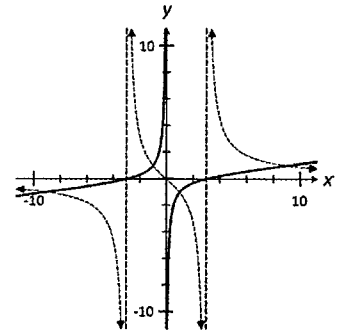

(c)

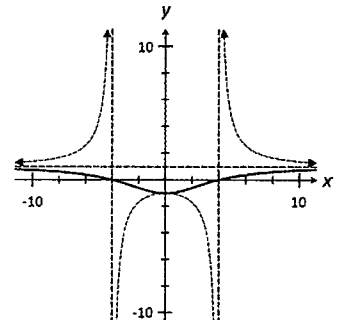

(d)

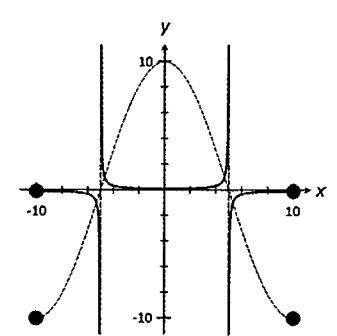

5. (a)

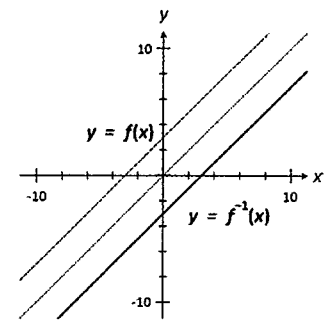

(b)

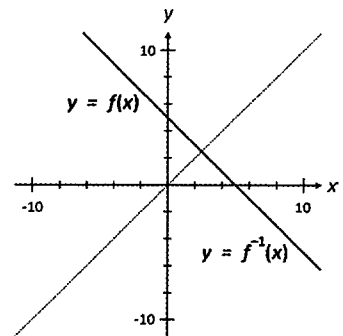

5. (c)

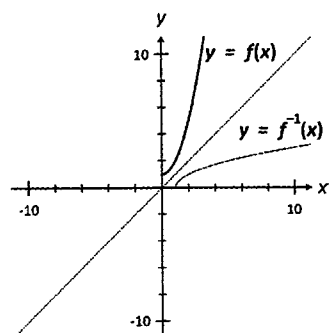

(d)

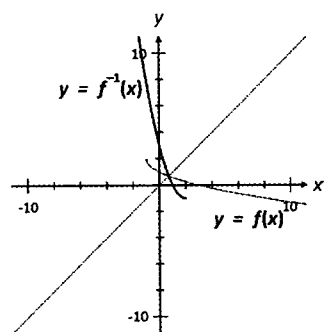

(e)

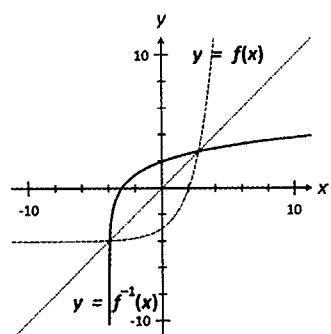

(f)

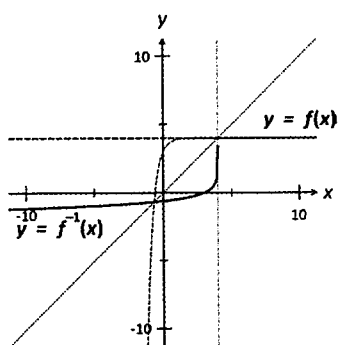

(g)

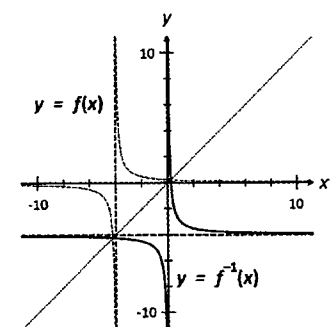

5. (h)

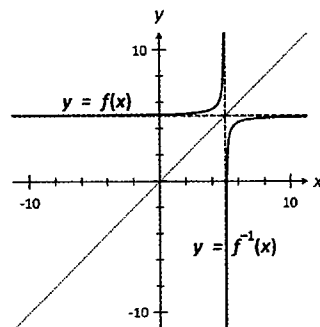

(i)

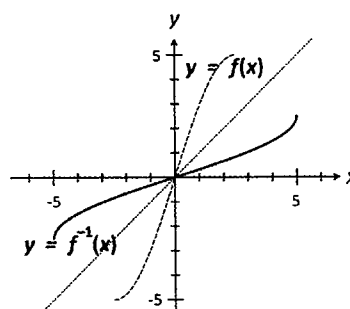

(j)

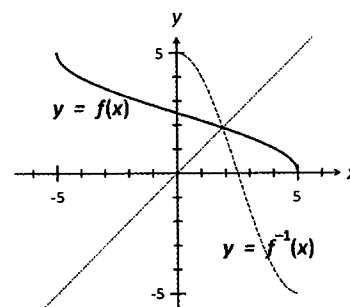

6. (a)

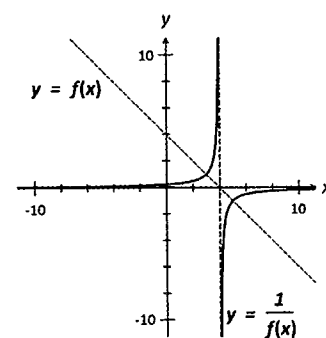

(b)

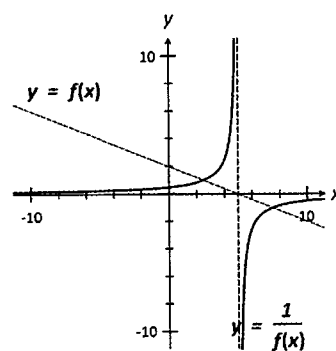

6. (c)

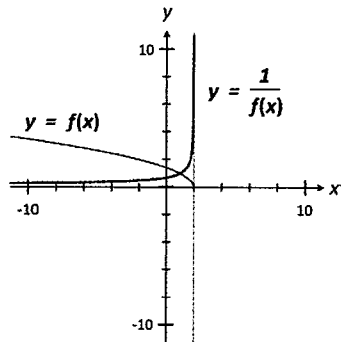

(d)

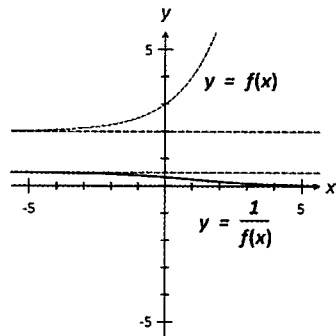

(e)

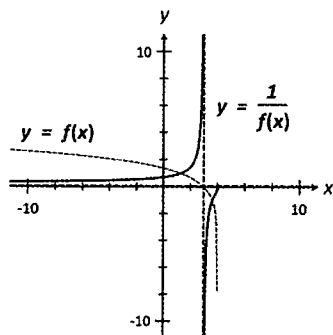

(f)

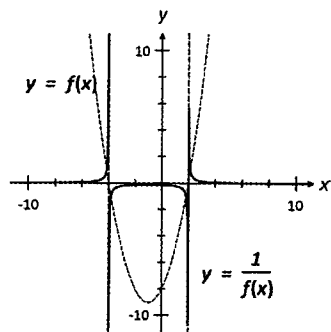

(g)

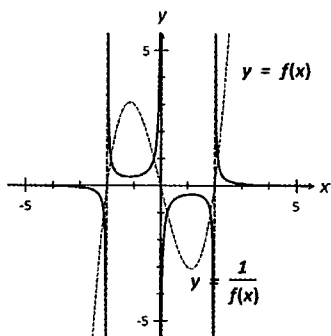

6. (h)

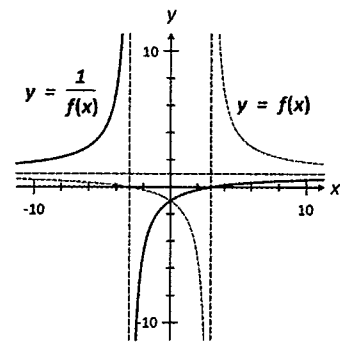

(i)

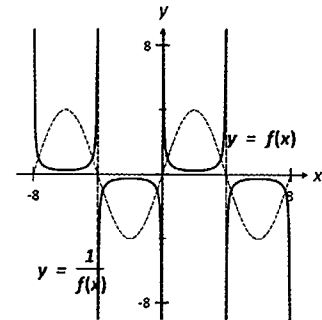

(j)

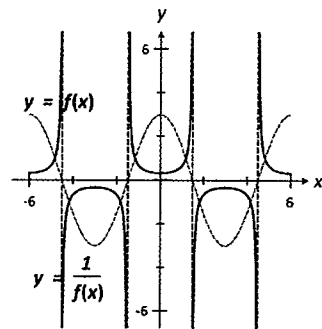

Exercise 5.2

1. (a) (i)

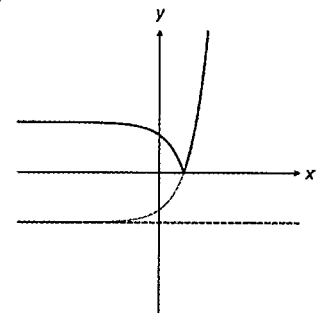

(ii)

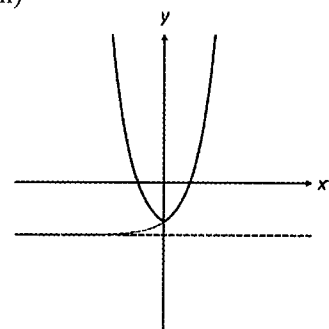

1. (b) (i)

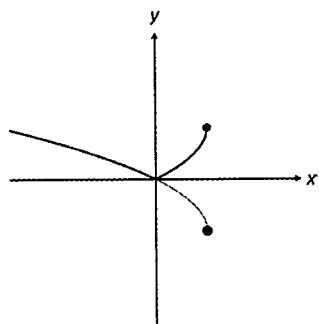

(ii)

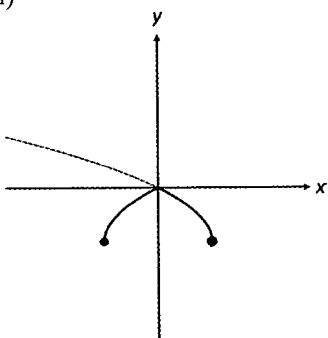

(c) (i)

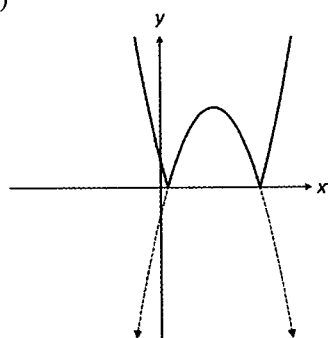

(ii)

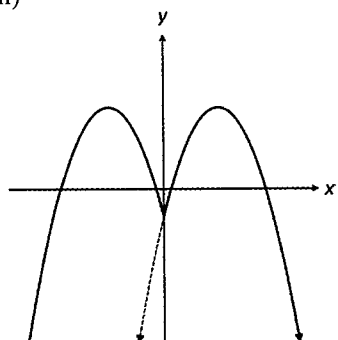

(d) (i)

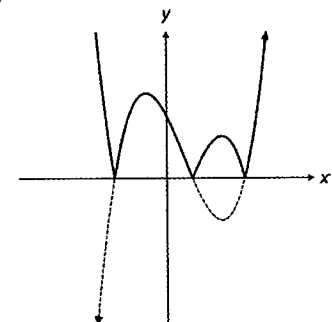

1. (d) (ii)

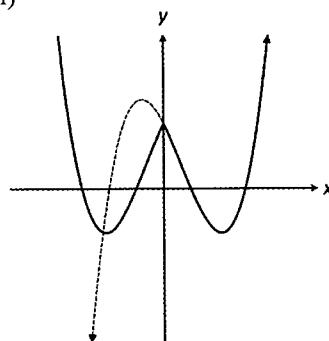

(e) (i)

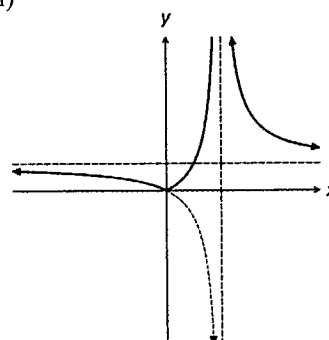

(ii)

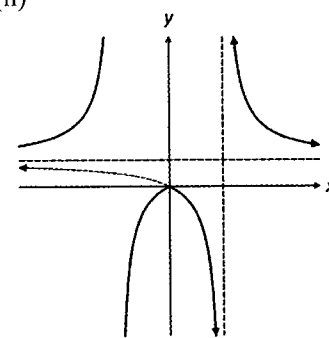

(f) (i)

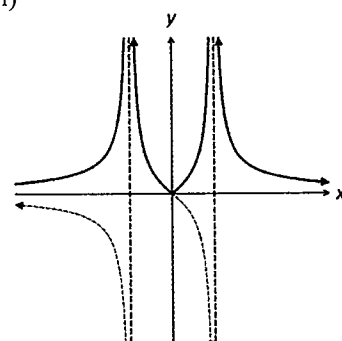

(ii)

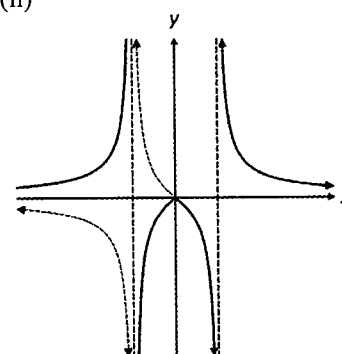

2. (a) (i) $|f(x)| = \begin{cases} -(2x+5) & x < -2.5 \\ 2x+5 & x \geq -2.5 \end{cases}$

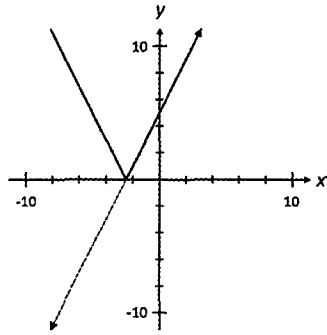

(ii) $f(|x|) = \begin{cases} -2x+5 & x < 0 \\ 2x+5 & x \geq 0 \end{cases}$

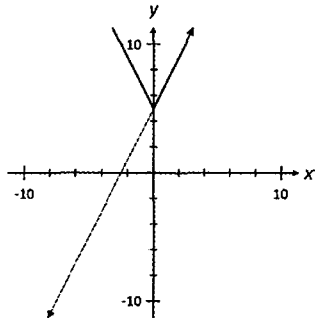

(b) (i) $|f(x)| = \begin{cases} 3-x & x < 3 \\ -(3-x) & x \geq 3 \end{cases}$

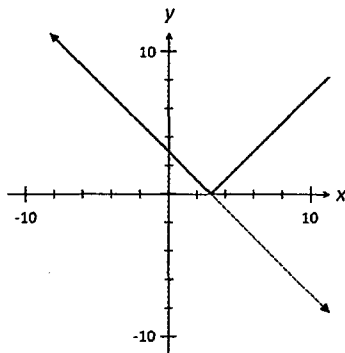

(ii) $f(|x|) = \begin{cases} 3+x & x < 0 \\ 3-x & x \geq 0 \end{cases}$

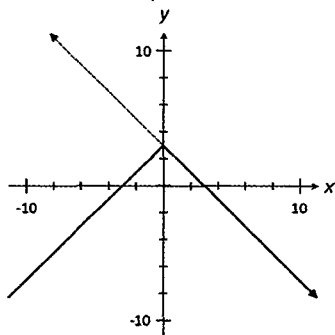

2. (c) (i)

$|f(x)| = \begin{cases} (x+3)(x-3) & x < -3, x > 3 \\ -(x+3)(x-3) & -3 \leq x \leq 3 \end{cases}$

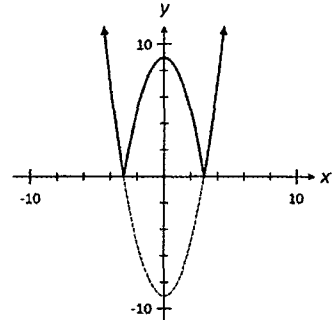

(ii) $f(|x|) = (x+3)(x-3)$

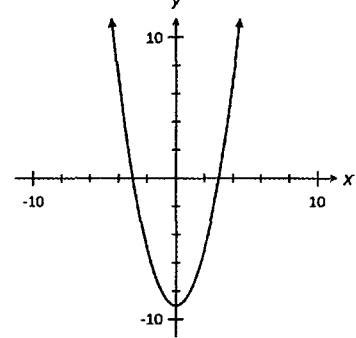

(d) (i)

$|f(x)| = \begin{cases} x^2 - 3x - 4 & x < -1, x > 4 \\ -x^2 + 3x + 4 & -1 \leq x \leq 4 \end{cases}$

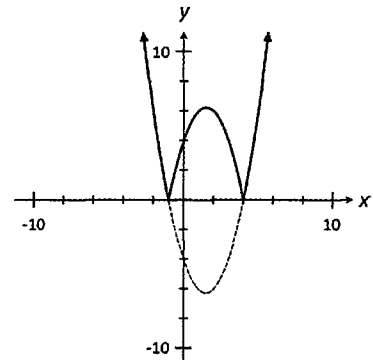

(ii) $f(|x|) = \begin{cases} x^2 + 3x - 4 & x < 0 \\ x^2 - 3x + 4 & x \geq 0 \end{cases}$

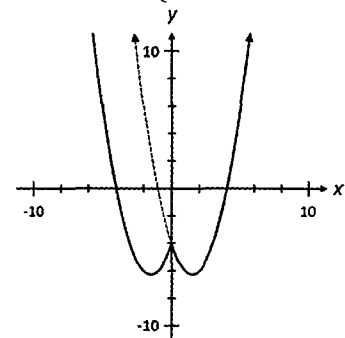

2. (e) (i) $|f(x)| = \begin{cases} 4-2^x & x < 2 \\ 2^x - 4 & x \geq 2 \end{cases}$

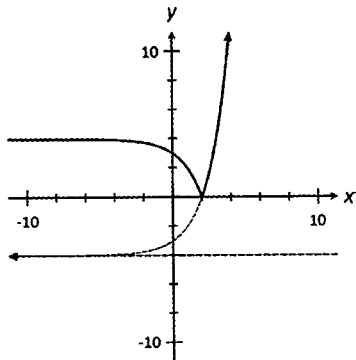

(ii) $f(|x|) = \begin{cases} 2^{-x} - 4 & x < 0 \\ 2^x - 4 & x \geq 0 \end{cases}$

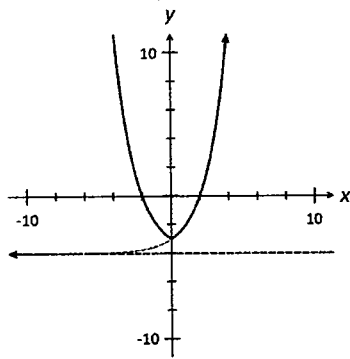

(f) (i) $|f(x)| = \begin{cases} -\ln(x+2) & x < -1 \\ \ln(x+2) & x \geq -1 \end{cases}$

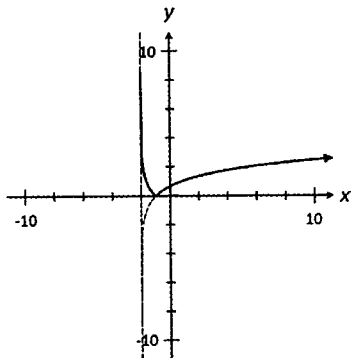

(ii) $f(|x|) = \begin{cases} \ln(-x+2) & x < 0 \\ \ln(x+2) & x \geq 0 \end{cases}$

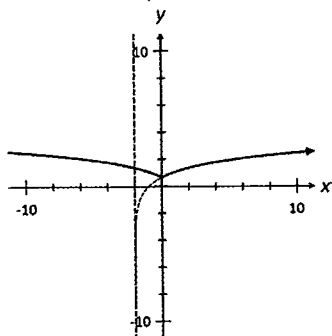

2. (g) (i)

$$|f(x)| = \begin{cases} -\sin x & (2n-1)\pi < x < 2n\pi \\ \sin x & 2n\pi \leq x \leq (2n+1)\pi \end{cases}$$

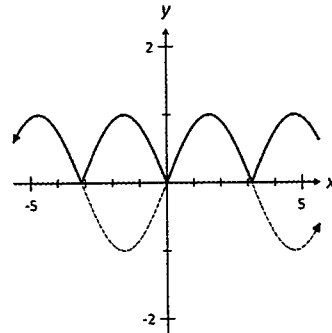

(ii) $f(|x|) = \begin{cases} \sin(-x) & x < 0 \\ \sin(x) & x \geq 0 \end{cases}$

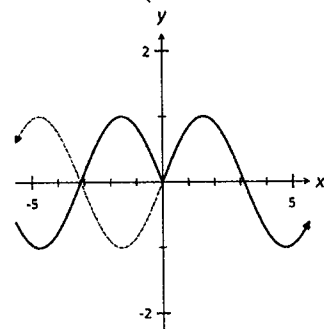

(h) (i) $|f(x)| =$

$$\begin{cases} -\cos x & \frac{(4n+1)\pi}{2} < x < \frac{(4n+3)\pi}{2} \\ \cos x & \frac{(4n-1)\pi}{2} \leq x \leq \frac{(4n+1)\pi}{2} \end{cases}$$

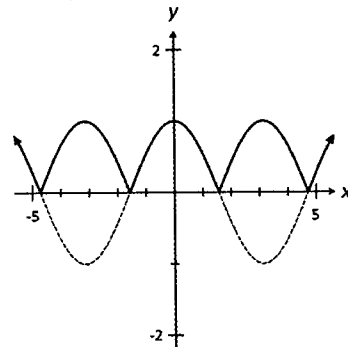

(ii) $f(|x|) = \begin{cases} \cos(-x) & x < 0 \\ \cos(x) & x \geq 0 \end{cases}$

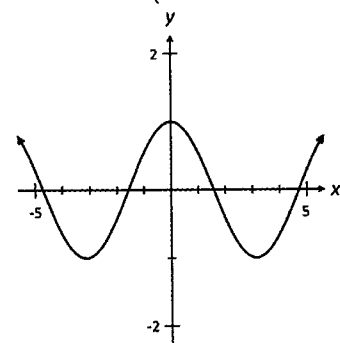

2. (i) (i) $|f(x)| = \begin{cases} \sqrt{4-x}-2 & x < 0 \\ 2-\sqrt{4-x} & x \geq 0 \end{cases}$

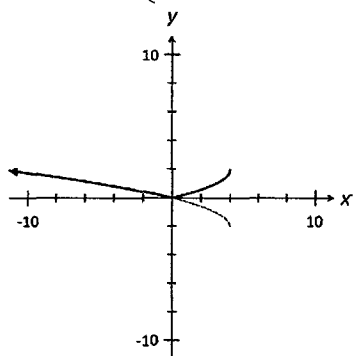

(ii) (i) $f(|x|) = \begin{cases} \sqrt{4+x}-2 & x < 0 \\ \sqrt{4-x}-2 & x \geq 0 \end{cases}$

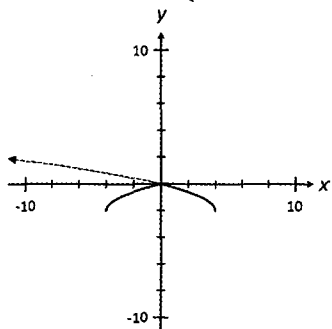

(j) (i) $|f(x)| = \begin{cases} e^{-2x}-2 & x < \frac{-\ln 2}{2} \\ 2-e^{-2x} & x \geq \frac{-\ln 2}{2} \end{cases}$

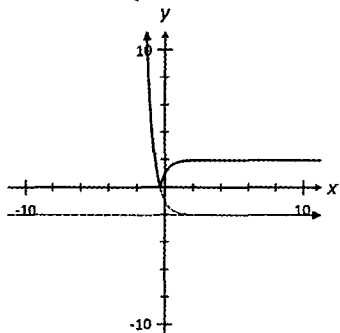

(ii) $f(|x|) = \begin{cases} e^{2x}-2 & x < 0 \\ e^{-2x}-2 & x \geq 0 \end{cases}$

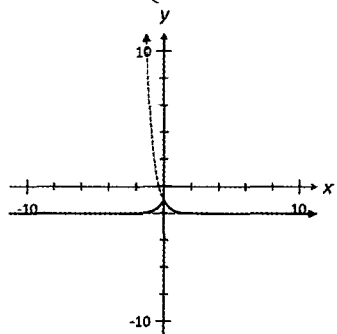

2. (k) (i) $|f(x)| = \begin{cases} -1/(x-2) & x < 2 \\ 1/(x-2) & x > 2 \end{cases}$

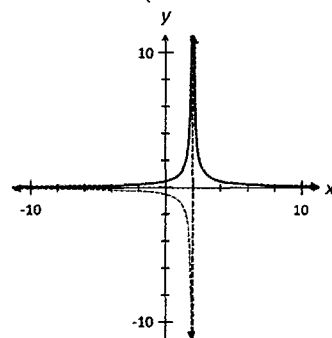

(ii) (i) $f(|x|) = \begin{cases} 1/(-x-2) & x < 2 \\ 1/(x-2) & x > 2 \end{cases}$

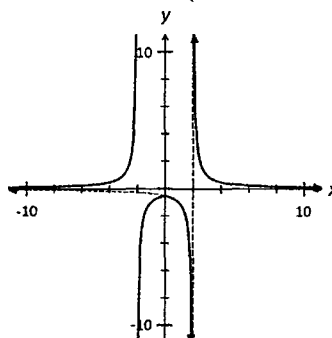

(j) (i) $|f(x)| = \begin{cases} -(1/(2+x)+2) & x < -5/2 \\ 1/(2+x)+2 & x > -5/2 \end{cases}$

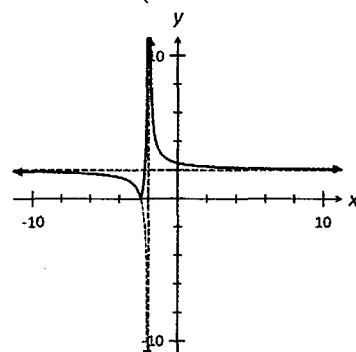

(ii) $f(|x|) = \begin{cases} 2+1/(2-x) & x < 0 \\ 2+1/(2+x) & x > 0 \end{cases}$

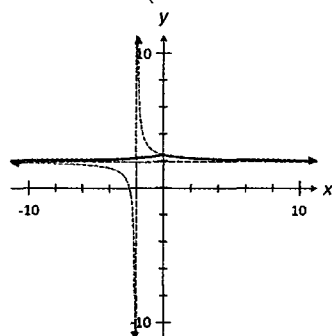

3. (a) (i)

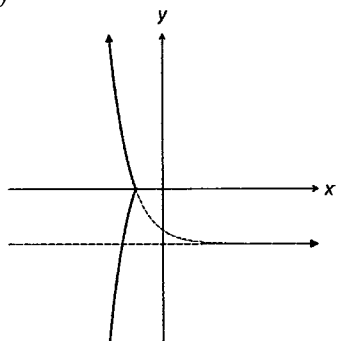

(ii)

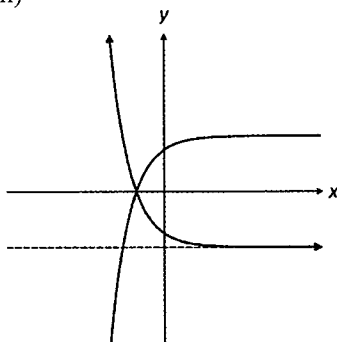

(b) (i)

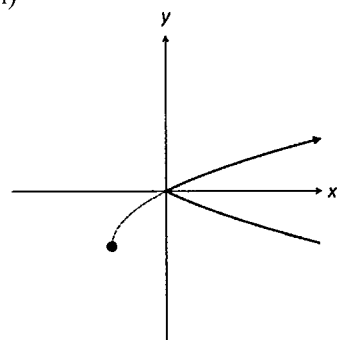

(ii)

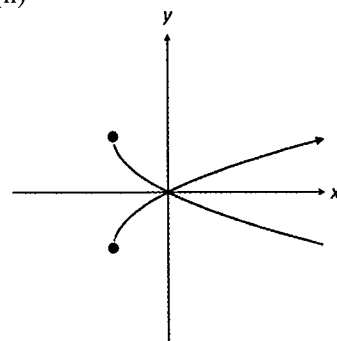

(c) (i)

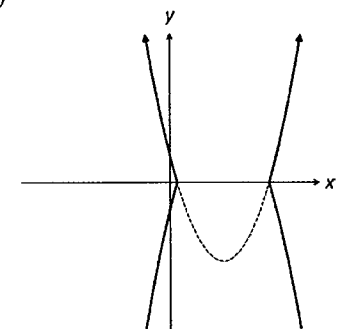

1. (c) (ii)

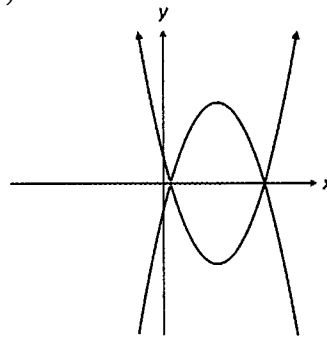

(d) (i)

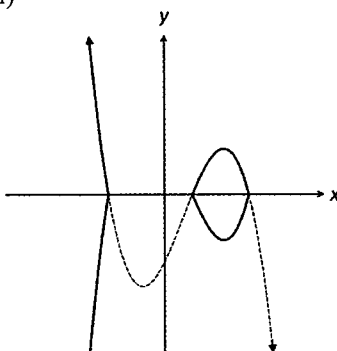

(ii)

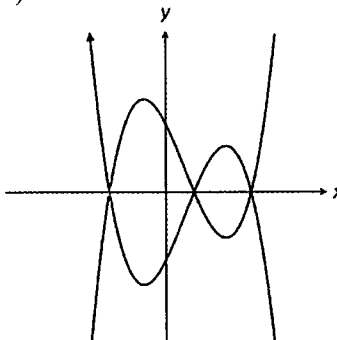

4. (a) (i)

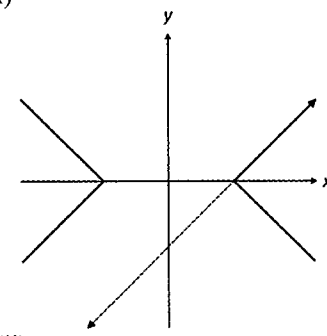

(ii)

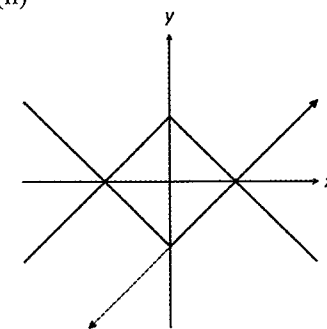

4. (b) (i)

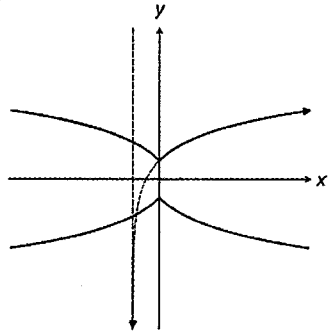

(ii)

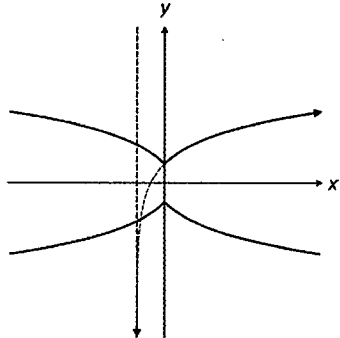

(c) (i)

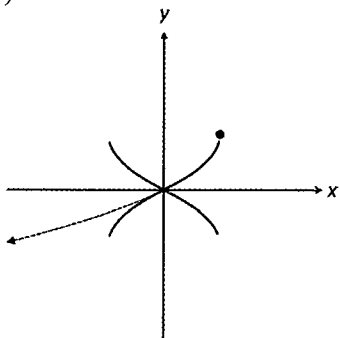

(ii)

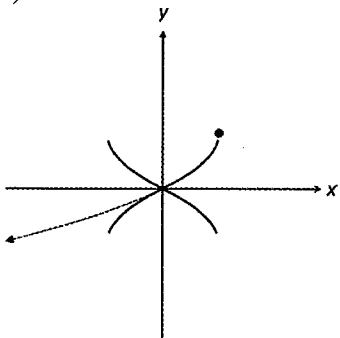

(d) (i)

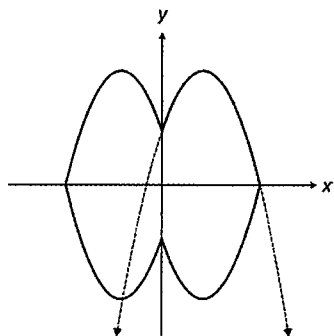

4. (d) (ii)

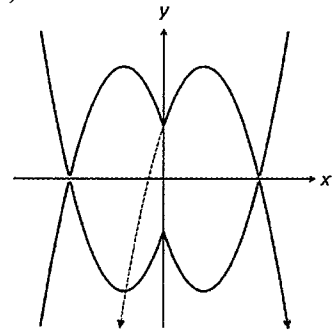

Exercise 5.3

1. (a)

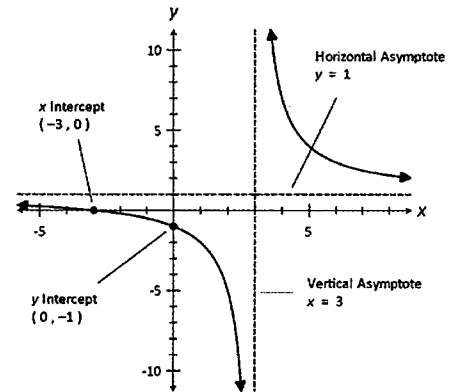

(b)

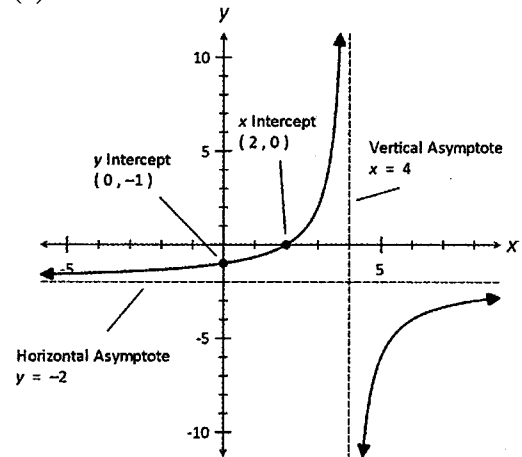

(c)

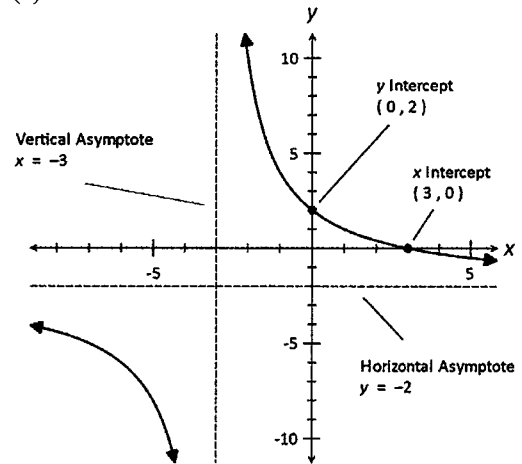

1. (d)

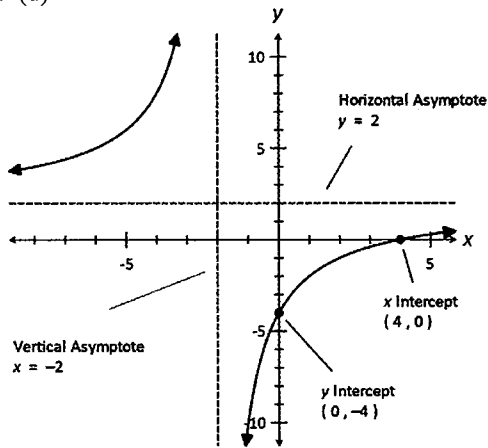

(e)

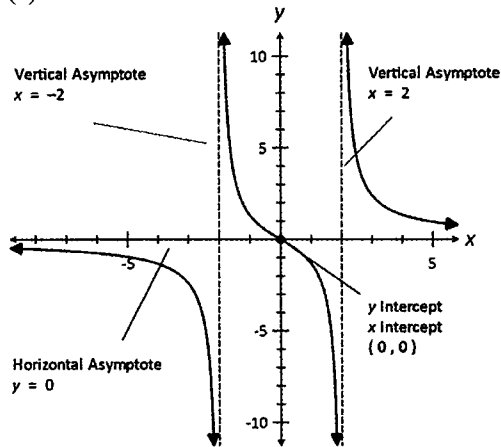

(f)

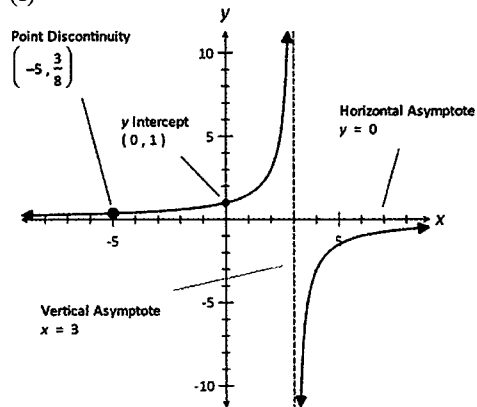

(g)

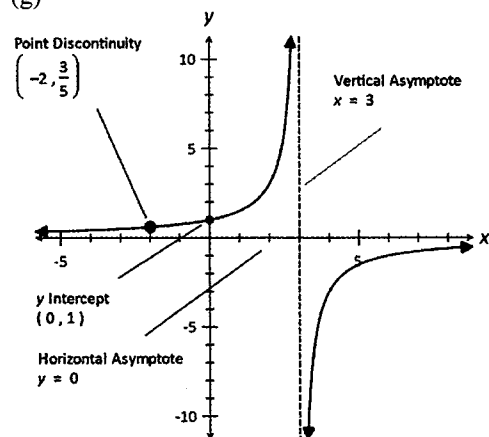

1. (h)

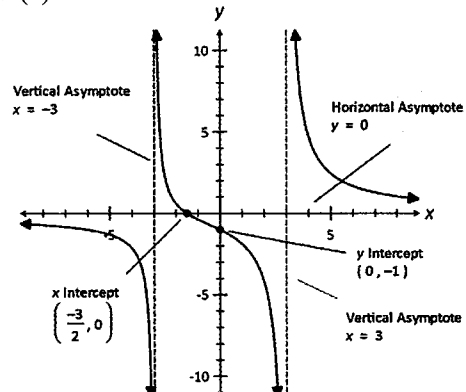

2. (a) (i) $y = (x + 2)/(x - 2)$
(ii)

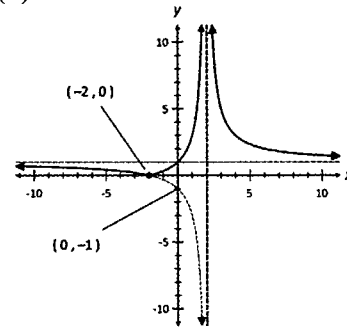

(iii)

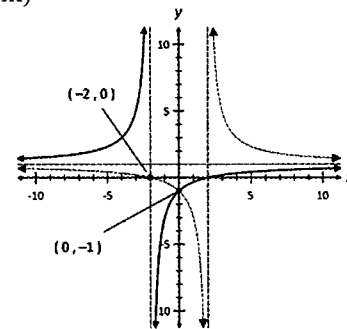

(b) (i) $y = (x - 2)/(x + 2)$
(ii)

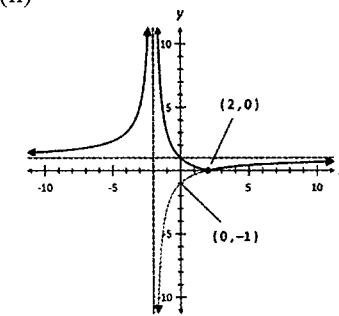

(iii)

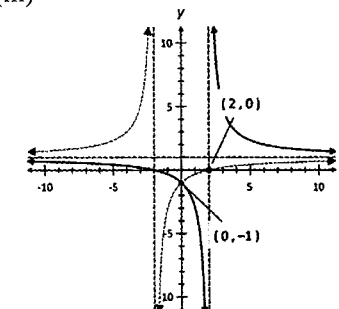

2. (c) (i) $y = (1 - 2x)/(x + 1)$
 (ii)

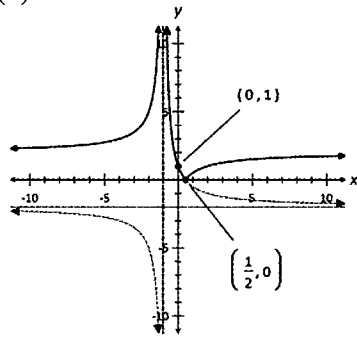

(iii)

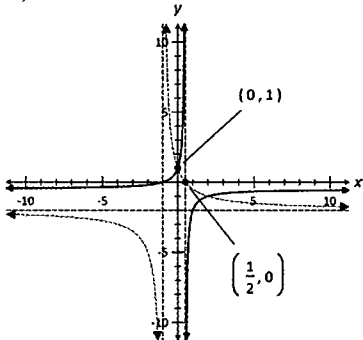

3. (a) $a = 2, b = 0, c = 1$
 (b)

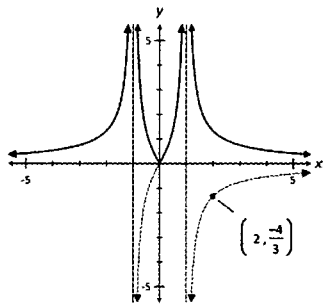

(c)

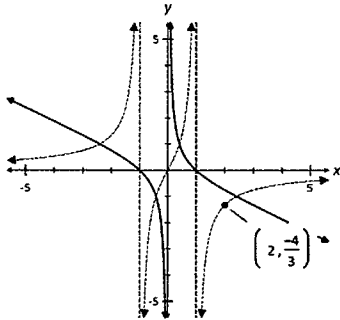

4. (a) $a = 2, b = -5, c = 1, d = 2$
 (b)

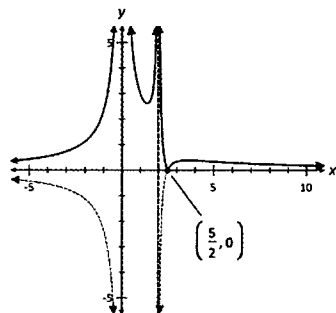

4. (c)

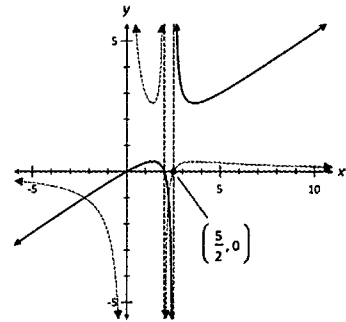

5. (a) $a = 4, b = 1, c = 3, d = -2$
 (b)

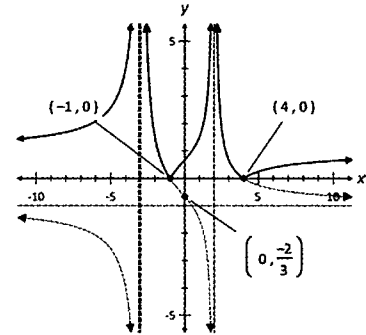

(c)

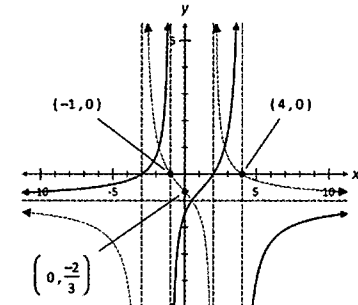

6. $a = k, b = -k, c = -2k, d = 4k, k$ is a real no.
 7. $a = 2, b = -1, c = 3, d = -1$
 8. $a = -1, b = 1, c = 1, d = -2$
 or $a = 1, b = -1, c = 1, d = -2$
 9. $a = 1, b = -1, c = 1, d = 2, e = 3, f = -3$
 ($ab = 1$ and $ad = -2$)
 10. (a) intercepts $(0, 0)$
 asymptotes $x = -2, x = 2, y = 1$
 (b) $a = -8$
 (c) max point $(0, 0)$
 (d)

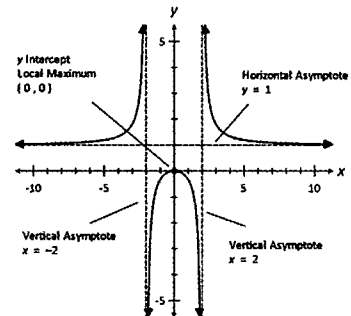

11. (a) intercepts $(0, 0)$; asymptotes $y = 0$
 (b) $a = 1, b = 1$

11. (c) min point $(-1, -1/2)$, max point $(1, 1/2)$
 (d)

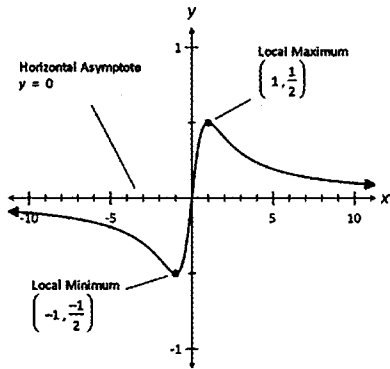

12. (a) no intercepts; asymptotes $x = 0$, oblique asymptote $y = 2x$
 (b) $a = 2, b = -800$
 (c) min point $(20, 80)$, max point $(-20, -80)$
 (d)

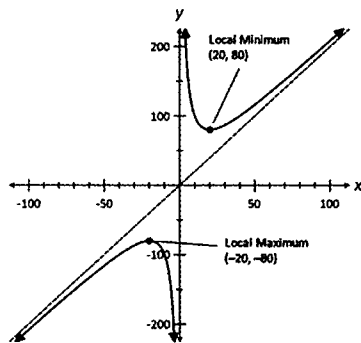

13. (a) no intercepts
 asymptotes $x = 0, x = -3, y = 1$
 (b) $a = 1, b = -3$ or $a = -3, b = 1$
 (c) min point $(3, 2/3)$, max point $(-1, -2)$
 (d)

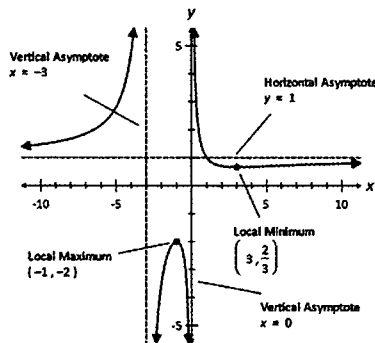

14.

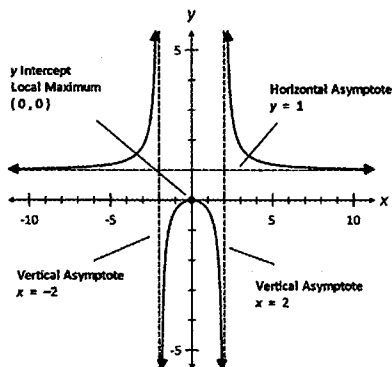

15.

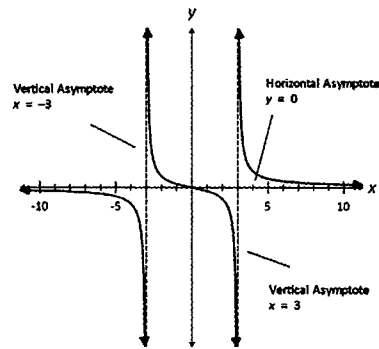

16.

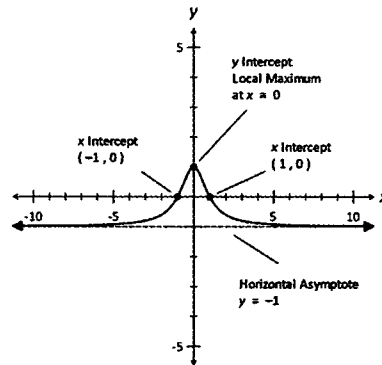

17.

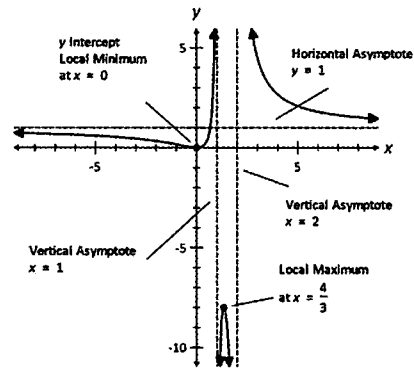

Exercise 5.4

1. (a) (i) $y = x - 2/(x - 1)$
 (iii)

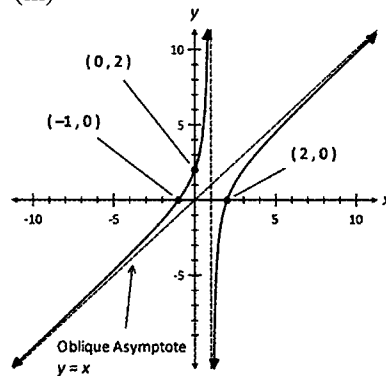

1. (b) (i) $y = -x + 1 + 4/(x + 2)$
(iii)

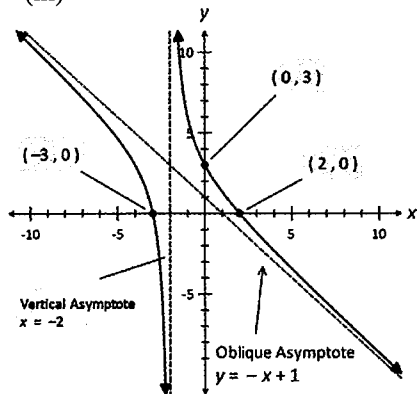

(c) (i) $y = x + 1 - 6/(x + 2)$
(iii)

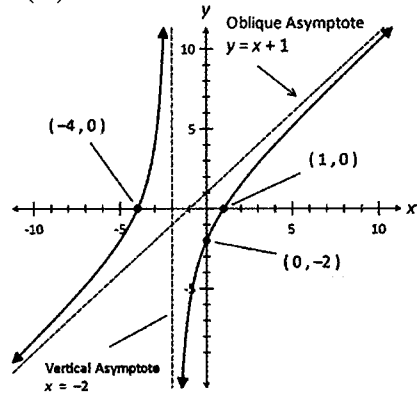

(d) (i) $y = x - 3 - 2/(x - 2)$
(iii)

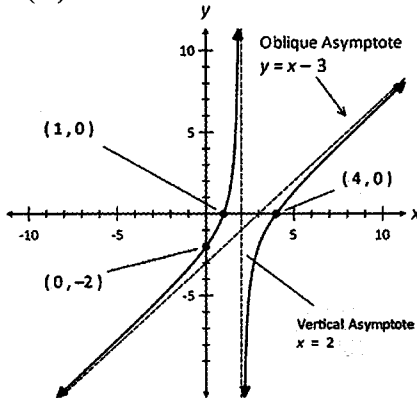

2. (a) (i) $y = x + 1/x$
(iv)

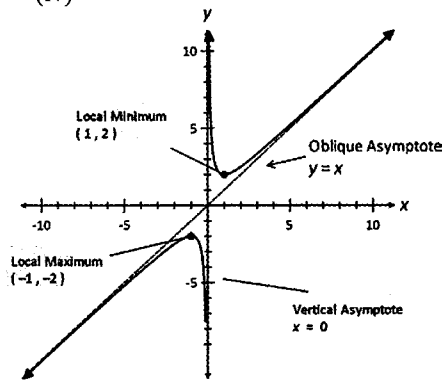

2. (b) (i) $y = -x - 1 - 1/x$
(iv)

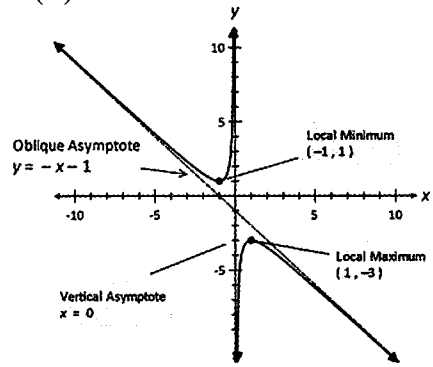

(c) (i) $y = x + 2 + 1/(x - 2)$
(iv)

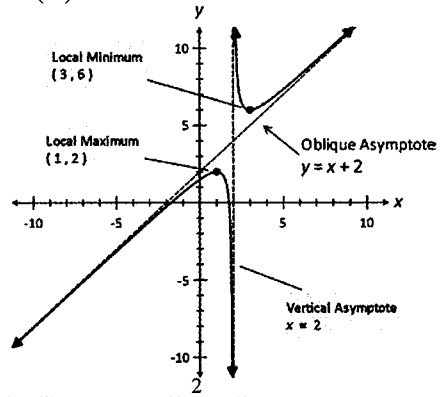

(d) (i) $y = x + x/(x - 1)$
(iv)

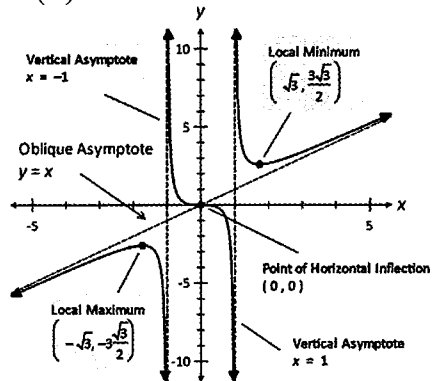

3. (a) $y = x - 4$

(b) $b = -4, c = -1, d = 4, n = -4$

(c)

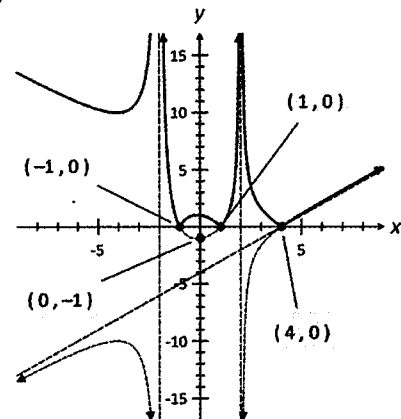

Exercise 6.1

1. (a)

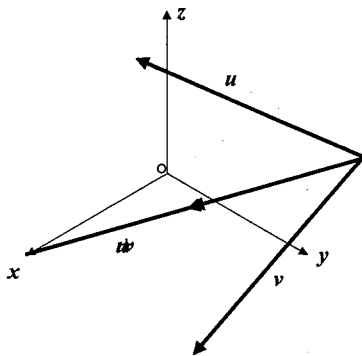

(b)

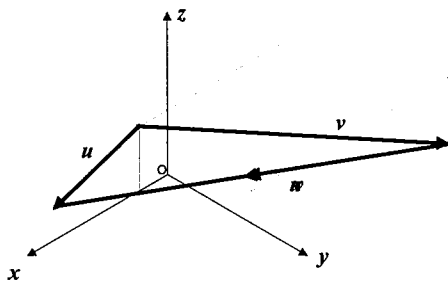

2. (a) $\langle 10, 3, 2 \rangle$ (b) $\langle 4, -15/2, 11 \rangle$
3. (a) $\pm 3\sqrt{43}$ (b) $10 \pm 10\sqrt{3}$
4. $\langle 8, -8, 8 \rangle$
5. (a) $((\sqrt{83})/83) \langle 5, -3, 7 \rangle$
(b) $-10((\sqrt{83})/83) \langle 5, -3, 7 \rangle$
6. (a) $\sqrt{(17/10)} \langle -1, 0, -3 \rangle$
(b) $((\sqrt{3})/(2\sqrt{17})) \langle 0, -1, -4 \rangle$
7. (a) $((\sqrt{59})/\sqrt{30}) \langle 2, -5, -1 \rangle$
(b) $(-10/\sqrt{17}) \langle -1, 0, 4 \rangle$
8. (a) $(5/\sqrt{6}) \langle -1, 1, 2 \rangle$
(b) $(-10/\sqrt{6}) \langle -1, 1, 2 \rangle$
9. $\pm (1/\sqrt{3}) \langle 1, -2, 1 \rangle$
10. $\pm 2\sqrt{6}$ 11. 0 or 1
12. (a) $\alpha = 1, \beta = -1$ (b) $\alpha = 1, \beta = 1$
14. $\alpha = -\beta/2$
15. $\alpha = 2, \beta = 4$ or $\alpha = 3, \beta = 5$
16. $5\alpha + 4\beta = 45$
17. (a) $(1/3) \langle -3, 1, 10 \rangle$
(b) $(1/5) \langle -8, 24, 52 \rangle$
18. $\langle -32, -14, 65 \rangle$
19. $(1/2) \langle 26, -10, -5 \rangle$
20. (a) 90° (b) 35.3° (c) 85.3° (d) 52.8°
21. (a) perpendicular (b) Neither
(c) Parallel, opposite direction
(d) Parallel, same direction
22. (a) $(5/\sqrt{13}) \langle 0, 3, 2 \rangle$ or equivalent.
(b) $(100/\sqrt{2}) \langle 1, 0, 1 \rangle$ or equivalent.
(c) $(10/\sqrt{5}) \langle 2, 0, 1 \rangle$ or equivalent.
(d) $(20/3) \langle 2, 2, 1 \rangle$ or equivalent.
23. $a = b = \sqrt{5}$ 24. $a = -9/8, b = 4$

25. $a = (\sqrt{2})/2, b = \pm (\sqrt{2})/2$
27. (a) $(1/3) \langle 2, 2, -1 \rangle$ (b) $\langle 1, 1, 1 \rangle$
28. (a) $(-5/9) \langle 2, -1, -2 \rangle$
(b) $\langle -1, 1, 2 \rangle$
29. $(1/16) \langle -5, 18, -7\sqrt{3} \rangle$
30. $(1/9) \langle -2, 16, 28 \rangle$
31. (a) $\langle 1, -1, 1 \rangle, \langle 0, 0, 0 \rangle$
(b) $\langle 1, -1, 1 \rangle, \langle 0, 0, 0 \rangle$
32. (a) $\langle 2, 1, 3 \rangle, \langle 3, -9, 1 \rangle$
(b) $\langle 3, -9, 1 \rangle, \langle 2, 1, 3 \rangle$
33. $\sqrt{(38/51)}$ 34. $(\sqrt{5})/6$
35. $(\sqrt{2})/2$

Exercise 6.2

3. (a) $\langle 5, 4, -7 \rangle$ (b) $\langle -6, -15, -8 \rangle$
4. $[(\sqrt{3})/3] \langle 1, -1, 1 \rangle$ 5. $(10\sqrt{3}) \langle 1, -1, -1 \rangle$
6. (a) $a = 1, b = -1$ (b) $m = 2, n = 2$
(c) $a = 3, b = -2$ (d) $a = 3, b = -4$
7. 40 8. 4 9. 18
10. (a) $(\sqrt{219})/15$ (b) $(\sqrt{154})/77$
11. $(\sqrt{2})/10$ 12. (a) $10\sqrt{2}$ (b) $5\sqrt{2}$
13. (a) $2\sqrt{77}$ (b) $\sqrt{77}$

Exercise 7.1

1. (a) $r = \langle 2, 1, 0 \rangle + \lambda \langle 4, 5, -1 \rangle$
(b) $r = \langle 0, 0, 5 \rangle + \lambda \langle 0, 2, -1 \rangle$
(c) $r = \langle 1, 1, -1 \rangle + \lambda \langle 1, 2, -1 \rangle$
(d) $r = \langle \sqrt{2}, 0, 1 \rangle + \lambda \langle 0, -1, 1/5 \rangle$
2. Equivalent answers including:
(a) $r = \langle 0, -2, 0 \rangle + \lambda \langle 0, -2, -2 \rangle$
(b) $r = \langle 1, 2, 1 \rangle + \lambda \langle -2, -3, 3 \rangle$
(c) $r = \langle 1, 2, 5 \rangle + \lambda \langle 3, 1, -2 \rangle$
(d) $r = \langle 0.5, -0.1, 0.4 \rangle + \lambda \langle 0.1, 0.4, 0.3 \rangle$
3. (a) $\lambda = 2$ (b) $\lambda = -5$
4. $m = 4$ 5. $m = 4$
6. $\langle 13, -2, 11 \rangle$ is the only point not on the line
7. (a) $r = \langle 0, 3 \rangle + \lambda \langle 1, -2 \rangle$
(b) $r = \langle 0, -1 \rangle + \lambda \langle 3, 4 \rangle$
(c) $r = \langle 0, 3 \rangle + \lambda \langle 4, -3 \rangle$
8. Gradient = -3 ; $y = -3x + 6$
9. $x = 3 + \lambda, y = 1 - 2\lambda; 2x + y = 7$
10. (a) $r = \langle -1, 2, 0 \rangle + \lambda \langle 1, -3, 0 \rangle$
(b) $r = \langle 1, 2, 4 \rangle + \lambda \langle 2, -1, -1 \rangle$
(c) $r = \langle 1, -4, 5 \rangle + \lambda \langle 1, 1, 3 \rangle$
(d) $r = \langle 0, 2, 10 \rangle + \lambda \langle 6, 1, 1 \rangle$
11. (a) $(x - 5)/2 = (y + 2)/(-3) = (z + 1)/5$
(b) $(x + 1)/(-2) = y - 5 = (z - 3)/(-4)$
(c) $(4x - 3)/2 = (3y + 2)/(-2) = 4z/5$
(d) $3(x - 1)/2 = -5(y + 1) = 5(z + 1)/3$
12. (a) $(x + 1) = (y + 2)/(-3) = (z - 2)/6$
(b) $(x + 1)/(-2) = (y + 5)/5 = (z - 6)/(-2)$
13. (a) $x = y = z$
(b) $(x + 1)/(-6) = (y - 3)/(-3) = (z - 4)/(8)$
(c) $(x - 3) = (z + 1)/(-2), y = 4$
(d) $x = 10, z = -5$

14. (a) $r = \langle \lambda, 2 + 5\lambda, 3 - 2\lambda \rangle$
 (b) $r = \langle 0, -1 - \lambda, 5 + 3\lambda \rangle$
 (c) $r = \langle (-1 - 3\lambda)/2, (-1 - 4\lambda)/2, (-5 + 5\lambda)/3 \rangle$
 (d) $r = \langle 1 + 5\lambda/4, (1 - 6\lambda)/3, -(2 - 3\lambda)/6 \rangle$
 15. $r = \langle 1, 2, 3 \rangle + \lambda \langle 5, -2, 0 \rangle$ or equivalent
 16. $r = \langle 2, 2, -2 \rangle + \lambda \langle 1, -2, 0 \rangle$ or equivalent
 17. (a) $x = a + \lambda u, y = b + \lambda v, z = c + \lambda w$
 (b) $\lambda = (x - a)/u = (y - b)/v = (z - c)/w$
 18. (a) Lines intersect at $\langle 13, 17, 4 \rangle$.
 (b) Lines do not intersect.
 19. $m \neq -7$ 20. $m = (-3n + 22)/(n - 6)$
 21. (a) 90° (b) 65.9°
 22. $r = \langle 1, 2, 1 \rangle + \lambda \langle 2, 2, 1 \rangle$ or equivalent

Exercise 7.2

1. (a) -2 (b) 4 (c) -34/5 (d) ± 5
 2. (a) No (b) No (c) Yes (d) No
 3. (a) $r \cdot \langle 2, -3 \rangle = -19$
 (b) $r \cdot \langle -5, 10 \rangle = -50$
 (c) $r \cdot \langle 10, 3 \rangle = -16$ or equivalent
 (d) $r \cdot \langle 5, -4 \rangle = 58$ or equivalent
 4. (a) $r \cdot \langle 6, 1 \rangle = 17$
 (b) $r \cdot \langle 3, -4 \rangle = -36$
 (c) $r \cdot \langle 8, -3 \rangle = -81$ or equivalent
 (d) $r \cdot \langle 7, 2 \rangle = 31$ or equivalent
 5. (a) $r \cdot \langle 1, 2 \rangle = 20$
 (b) $r \cdot \langle -4, 3 \rangle = 0.7$
 (c) $r \cdot \langle 3, 10 \rangle = -155$ or equivalent
 (d) $r \cdot \langle -2.7, 0.8 \rangle = 2.27$ or equivalent
 6. (a) $r = \langle 0, -6 \rangle + \lambda \langle 2, 1 \rangle$ or equivalent
 (b) $r = \langle -2, 0 \rangle + \lambda \langle 8, -5 \rangle$ or equivalent
 (c) $r = \langle -5, 0 \rangle + \lambda \langle 4, \sqrt{3} \rangle$ or equivalent
 7. (a) No intersection (b) No intersection
 (c) $\langle 5, 7 \rangle$ (d) $\langle -2, 0 \rangle$
 8. (a) 0° (b) 45°

Exercise 7.3

1. (a) -16 (b) -9/8 (c) -3/2 (d) -6/5
 2. (a) Only $\langle 2, 2, 4 \rangle$ is on the plane.
 (b) Both points are not on the plane.
 3. (a) $r \cdot \langle 4, 0, 3 \rangle = 5$
 (b) $r \cdot \langle -3, 7, 10 \rangle = 26$
 (c) $r \cdot \langle 1, 4, 1 \rangle = 33$
 (d) $r \cdot \langle 4, 8, -11 \rangle = -120$
 4. (a) $r \cdot \langle -1, 0, 2 \rangle = -11$
 (b) $r \cdot \langle 3, -2, -2 \rangle = 23$
 (c) $r \cdot \langle -4, 7, 9 \rangle = -17$
 (d) $r \cdot \langle 1, 10, -10 \rangle = -27/4$
 5. (a) $\langle 0, 4, -8 \rangle$ (b) $\langle 8, 11, -1 \rangle$
 (c) $\langle -1, 8, -7 \rangle$ (d) $\langle -15/2, 5, -21/4 \rangle$
 6. Equivalent answers including:
 (a) (i) $r \cdot \langle 1, 0, 0 \rangle = 0$
 (ii) $r = \lambda \langle 0, 1, 0 \rangle + \mu \langle 0, 0, 1 \rangle$
 (b) (i) $r \cdot \langle 1, 1, 1 \rangle = 8$
 (ii) $r = \langle 1, 2, 5 \rangle + \lambda \langle 4, 0, -4 \rangle$
 $+ \mu \langle 1, -1, 0 \rangle$

6. (c) (i) $r \cdot \langle 1, -1, 1 \rangle = -1$
 (ii) $r = \langle -2, 3, 4 \rangle + \lambda \langle -5, -7, -2 \rangle$
 $+ \mu \langle 8, 0, -8 \rangle$
 (d) (i) $r \cdot \langle -67, 11, -12 \rangle = -254$
 (ii) $r = \langle 4, 10, 8 \rangle + \lambda \langle 2, -2, -13 \rangle$
 $+ \mu \langle -1, -5, 1 \rangle$

7. Equivalent answers including:

- (a) $r \cdot \langle -4, -2, 1 \rangle = 3$
 (b) $r \cdot \langle -11, -38, 13 \rangle = -72$

8. Equivalent answers including:

- (a) $r \cdot \langle 0, 2, 1 \rangle = -1$
 (b) $r \cdot \langle -28, 5, 21 \rangle = 45$

9. (a) $r \cdot \langle 2, 8, 9 \rangle = -27$

- (b) $r \cdot \langle -6, 3, 1 \rangle = 11$

10. Equivalent answers including:

- (a) $r \cdot \langle 6, 0, 1 \rangle = 27$

- (b) $r \cdot \langle 2, -1, 0 \rangle = -13$

11. (a) $3z = 5$ (b) $-2y = 5$

- (c) $-2x - 4y + 3z = 10$

- (d) $5x + 2y - 6z = 25$

12. (a) $r \cdot \langle 1, 0, 0 \rangle = 5$

- (b) $r \cdot \langle 1, 1, 0 \rangle = 1$

- (c) $r \cdot \langle 0, 1, 1 \rangle = 6$

- (d) $r \cdot \langle 2, -3, 4 \rangle = 8$

13. $\langle 19, -3, -21 \rangle$

Exercise 7.4

1. (a) 53.1° (b) 22.2° (c) 20.9° (d) 32.6°
 2. 0.57 or 7.43 3. 1.05 or 19.75
 4. $r = \langle 3 + 5\lambda, 2 + 2\lambda, -1 - 8\lambda \rangle$
 5. (a) 90° (b) 90° (c) 76.1° (d) 87.9°
 6. -0.79 or 58.29 7. -19.62 or 3.62
 8. $m = 2 \pm \sqrt{n^2 + 3}$ 9. 55.5°
 10. $r \cdot \langle 1, -3, 0 \rangle = -1$ or equivalent

Exercise 7.5

1. (a) $|r - \langle 3, 4, 0 \rangle| = 3;$
 $\frac{(x-3)^2}{2} + \frac{(y-4)^2}{2} + z^2 = 9$
 (b) $|r - \langle -1, 2, 2 \rangle| = 5;$
 $\frac{(x+1)^2}{2} + \frac{(y-2)^2}{2} + \frac{(z-2)^2}{2} = 25$
 (c) $|r - \langle -1, 2, -5 \rangle| = \sqrt{10};$
 $\frac{(x+1)^2}{2} + \frac{(y-2)^2}{2} + \frac{(z+5)^2}{2} = 10$
 (b) $|r - \langle 1, 4, -5 \rangle| = 4;$
 $\frac{(x-1)^2}{2} + \frac{(y-4)^2}{2} + \frac{(z+5)^2}{2} = 16$

2. $2\sqrt{2}$

3. $\langle 1, 2, 1 \rangle$ or $(-1/3) \langle 11, 8, 11 \rangle$

4. (a) Outside (b) Inside

5. (a) $|r - \langle -1, 2, -3 \rangle| = 5$

- (b) $|r - \langle 1/2, 3/2, 1 \rangle| = (5\sqrt{6})/6$

6. (a) $\langle 1, 6, 0 \rangle$ or $(1/3) \langle -8, -4, 11 \rangle$

- (b) $\langle 5, -3, -2 \rangle$ or $(1/3) \langle -5, 11, 14 \rangle$

9. $|r - \langle -2, 2, -3 \rangle| = \sqrt{26}$

10. (a) Circle with equation $y^2 + z^2 = 64$
 (b) No intersection.
11. (a) Circle with equation $y^2 + z^2 = 99/4$
 (b) At the point $(1, 0, 5)$

Exercise 7.6

- | | |
|---------------------------|---------------------------|
| 1. (a) $(2\sqrt{357})/17$ | (b) $(\sqrt{445})/5$ |
| (c) $(3\sqrt{2310})/35$ | (d) $(3\sqrt{2})/2$ |
| 2. $k = 7$ or -13 | 3. $k = 0$ or -6 |
| 4. (b) $\sqrt{5}$ | 5. (b) $(2\sqrt{138})/69$ |
| 6. (a) $(3\sqrt{21})/7$ | (b) $(13\sqrt{42})/21$ |
| 7. (a) 2 | (b) 2 |
| (c) 1 | (d) 5 |
| (e) $5\sqrt{6}$ | (f) 6 |
| 8. $2 \pm 10\sqrt{6}$ | 9. $-2/3$ |
| 10. (a) $\sqrt{10}$ | (b) $\sqrt{2}$ |
| 11. $2/3$ | 12. 3 |
| 13. $1/3$ | 14. $(3\sqrt{14})/14$ |

Exercise 8.1

1. (a) $y = 0$

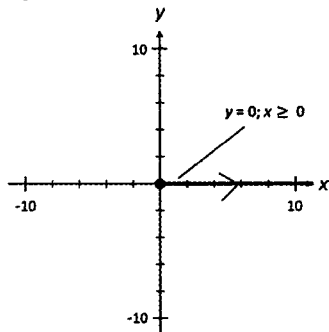

- (b) $x = 0$

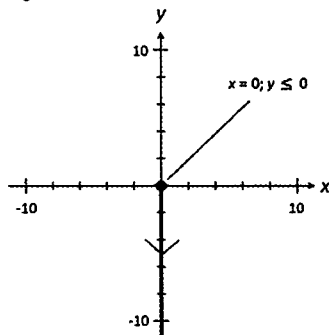

- (c) $y = 4$

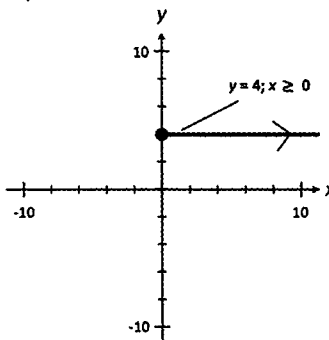

1. (d) $x = -3$

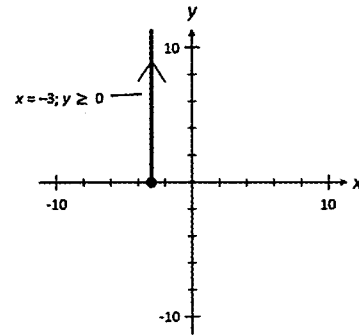

- (e) $y = -2x$

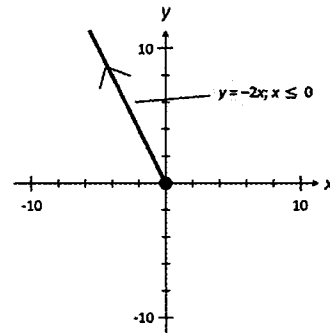

- (f) $y = 1 - x$

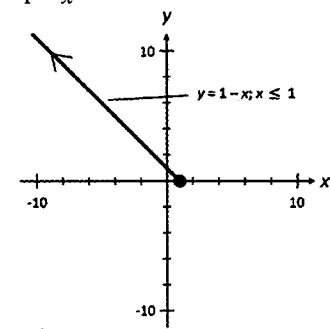

- (g) $y = x^2$

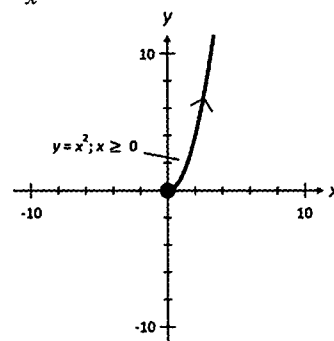

- (h) $y^2 = x$

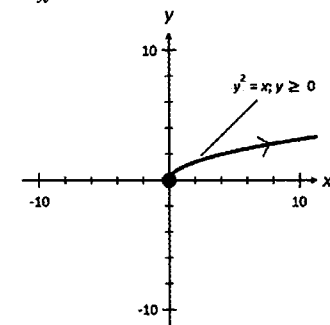

1. (i) $y^2 = 4x - 4$

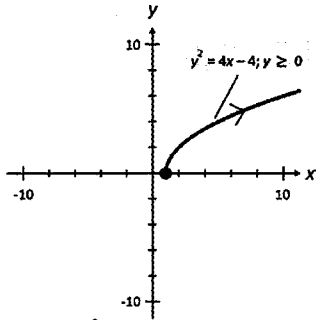

(j) $y = -(x-1)^3$

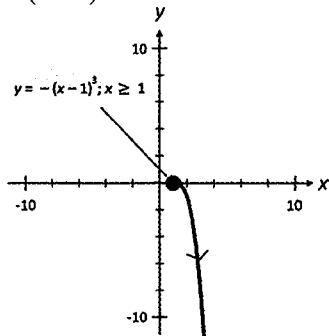

(k) $y = x e^x$

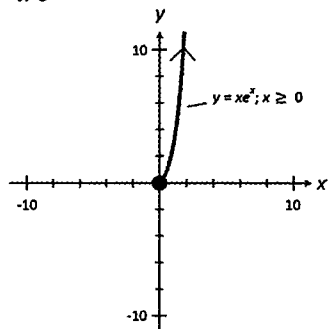

(l) $y = -x + 1/x$

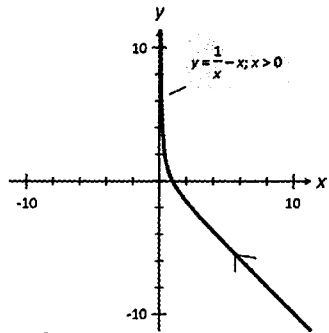

2. (a) $x^2 + y^2 = 1$

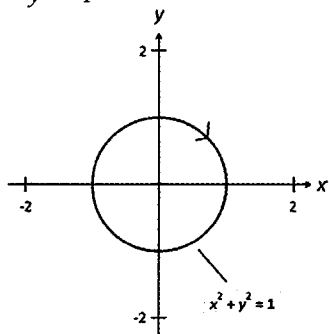

2. (b) $x^2 + y^2/4 = 1$

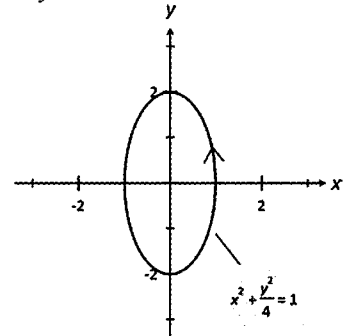

(c) $x^2/4 + y^2 = 1$

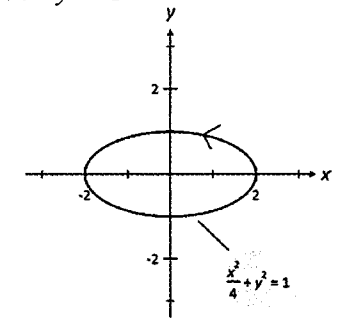

(d) $x^2/9 + y^2/4 = 1$

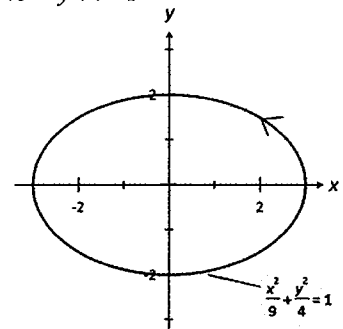

(e) $(x-1)^2 + (y-2)^2 = 1$

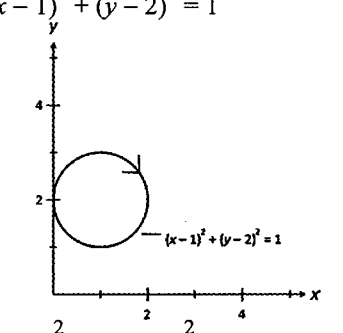

(f) $(x-1)^2/4 + (y-4)^2 = 1$

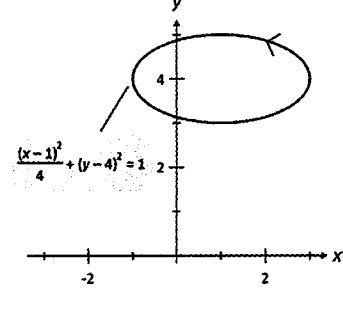

2. (g) $x^2 + y^2 = 1$

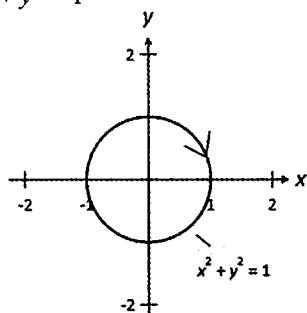

(h) $x^2 = 4y(1-y)$

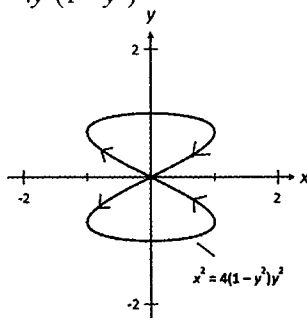

Exercise 8.2

1. (a) Collide at $t = 2$
 (b) Path of A: $r = \lambda < 1, -2 >$
 Path of B: $r = < 2, -9 > + \mu < 2, 1 >$
 Intersect at $< 4, -8 >$.
2. (a) Do not collide.
 (b) Path of P: $r = < 0, 1 > + \lambda < 1, 1 >$
 Path of Q: $r = < -1, 0 > + \mu < 2, 3 >$
 Intersect at $< -1, 0 >$.
3. (a) $< 5 + t, 2 + t, -10 + 5t > \text{m}$
 (b) 20.8 sec (c) 25.0 sec
4. (a) $a = -5, b = 10, c = -15$ (b) 10 am
5. (a) 5.1 sec and 6.1 sec after 0800 hrs
 (b) 134.4 m, 5.6 sec after 0800 hours.
6. (a) 563.8 m, 0.5 sec before 1 pm
 (b) 3.9 sec before 1 pm and 2.8 sec after 1 pm
7. (a) $\mathbf{OA}(t) = < 100 + 10t, 90 - 40t, 80 + 60t > \text{m}$
 $\mathbf{OB}(t) = < -200 + 22t, 150 - 42.4t, -80 + 66.4t > \text{m}$
 (b) Collide 25 sec after 0800 hours at $< 350, -910, 1580 > \text{m}$.
8. Collision at 6.45 am at $< -5, 110, 0.8 > \text{km}$
9. Interception at 4.30 pm at $< 225, 105, 4.7 > \text{nm}$
10. A and C will collide at 11 am at $< 25, 21, 10 >$.
11. (a) $< x - 4, y - 6, z + 0.15 > \text{ms}^{-1}$
 (b) $< 800, -800, -40 > \text{m}$
 (c) $x = 5, y = 5, z = -0.2$
12. $x = 0.49, y = 3.12, z = -0.12$
13. (a) No intersection. (b) $< -10, 5, 10 >$
 (c) $< 10, 0, 4 >$ (d) No intersection.
14. The two vehicles do not collide.
 Their paths do not intersect.
15. The two vehicles do not collide.
 Their paths intersect at $< 430, 410, 10.9 > \text{m}$.

Exercise 9.1

Please refer to Solution Manual for this text.

Exercise 9.2

Please refer to Solution Manual for this text.

Exercise 10.1

1. (a) $x = 4, y = 1, z = 2$
 (b) $x = 1, y = 2, z = 3$
 (c) $x = 1, y = 4, z = -2$
 (d) $x = 3, y = 3, z = 3$
 (e) $x = 2, y = 1, z = 1$
 (f) $x = -3, y = -4, z = 6$
 (g) $x = 1, y = 2, z = 4$
 (h) $x = -1, y = 2, z = -5$
 (i) $x = -2, y = 12, z = 2$
2. (a) $x = 5, y = 6, z = 1$
 (b) $x = -2, y = 4, z = 3$
 (c) $x = 1, y = 2, z = 3$
 (d) $x = 1/2, y = 1/2, z = -5/8$
3. (a) $x = 2, y = 4, z = -1$
 (b) $x = 3, y = -4, z = 3$
 (c) $x = 3, y = 9/2, z = 9/2$
 (d) $x = 5/2, y = 1, z = 1/4$
4. (a) $x = 4/5, y = 4/5, z = 4/5$
 (b) $x = 5, y = 10, z = 20$
 (c) $x = -1, y = -1, z = 1/2$
 (d) $x = \pm\sqrt{3}, y = \pm\sqrt{2}, z = \pm 1$
5. (a) $x = 1, y = 2, z = -4$ (b) No solution.

Exercise 10.2

1. A costs \$4.90, B costs \$3.90, C costs \$6.50
2. 15 P type, 14 Q type, 13 R type houses
3. 70 of A, 100 of B and 120 of C
4. NBL final \$32, AFL final \$18, Concert \$27
5. (a) 20 of P, 15 of Q, 25 of R
 (b) 4 of P, 3 of Q, 5 of R
6. 10 of A, 15 of B and 18 of C
7. $x = 70, y = 80, z = 60$
8. $x = 5, y = 1, z = 3$
9. 500 of 0 – 1 years, 1700 of 2 – 8 years and 200 of 9 – 10 years
10. (a) 2 red bricks, 8 white bricks, 20 blue bricks
 (b) 1005 of A, 620 of B, 750 of C
11. Any reasonable whole number for n .
12. (a) $x = 20, y = 40, z = 50$
 (b) Loop flow between the junctions C, D and B.
 (c) $k = -11.2$ litres/hour
13. $< t + 4, -t - 1, t > \quad t \in \mathbb{R}$
14. $< 2t + 13, t + 6, t > \quad t \in \mathbb{R}$

Exercise 10.3

1. (a) Equations 1 & 2 inconsistent.
 (b) Equation 1 + Equation 2 inconsistent with Equation 3.
 (c) Equations 1 & 2 inconsistent.
 (d) Equation 2 – Equation 1 inconsistent with Equation 3.

2. (a) Equations 1 & 2 are identical.
 (b) Equation 1 – Equation 2 similar to Equation 3.
 (c) $2 \times$ Equation 1 + Equation 2 similar to Equation 3.
 (d) Equation 2 – Equation 1 similar to Equation 3.
3. (a) (i) $p \neq 0, q$ any no. (ii) $p = 0, q \neq 1$
 (iii) $p = 0, q = 1$
 (b) (i) $p \neq 3, q$ any no. (ii) $p = 3, q \neq \frac{1}{2}$
 (iii) $p = 3, q = \frac{1}{2}$
 (c) (i) $p \neq -1$ (ii) $p = -1$
 (iii) No value for p
 (d) (i) $p \neq 1, p \neq -2$; any real number for q
 (ii) $p = 1$ and $q \neq 1$ or $p = -2$ and $q \neq 1$
 (iii) $p = 1$ and $q = 1$ or $p = -2$ and $q = 1$
 (e) (i) $p \neq -1$ and $p \neq -2$
 (ii) $p = -1$ (iii) $p = -2$
 (f) (i) $p \neq 3$ (ii) No value for p
 (iii) $p = 3$
4. (a) System will always have no solutions.
 (b) (i) System will always have solutions.
 (ii) $k \neq 4, k \in \mathbb{R}$
 $x = 19/7, y = -11/7, z = 0$
 (iii) $k = 4$
 $x = (19 - t)/7, y = (5t - 11)/7$
 $z = t, t \in \mathbb{R}$
 (c) (i) System will always have solutions.
 (ii) $k \neq 7, k \in \mathbb{R}$
 $x = 0, y = -1, z = 2$
 (iii) $k = 7$
 $x = (14 - 7t)/19, y = (3 - 11t)/19$
 $z = t, t \in \mathbb{R}$
 (d) (i) $k \neq -5, k \in \mathbb{R}$
 (ii) Not possible.
 (iii) $k = -5$
 $x = 1 - t, y = 1 - t, z = t, t \in \mathbb{R}$
5. $k = 5/4, 2$ 6. $a = 9, b = 1$

7. (a)
$$\left(\begin{array}{ccc|c} 1 & 3 & 1 & 16 \\ 1 & 4 & 3 & 23 \\ 1 & 2 & 4 & 19 \\ 1 & 5 & 3 & p \end{array} \right)$$

(b) Variations possible,

$$\left(\begin{array}{ccc|c} 1 & 3 & 1 & 16 \\ 0 & -1 & -2 & -7 \\ 0 & 0 & -5 & -10 \\ 0 & 0 & -2 & -30+p \end{array} \right)$$

- (c) $p = 26$
8. (a) $k = 1$
 (b) $k = -2$
 $x_1 = -5 + 4t, x_2 = 8 - 6t, x_3 = t, x_4 = 5 - 4t$
 (c) $k \neq 1$ and $k \neq -2, k \in \mathbb{R}$
 $x_1 = (k + 1)/(1 - k), x_2 = (2k + 1)/(k - 1),$
 $x_3 = (2k - 3)/(2k - 2), x_4 = (k + 1)/(k - 1)$

9.
$$\frac{1}{3} \begin{pmatrix} 2 & 1 & 1 \\ -1 & 1 & 1 \\ -2 & -1 & 2 \end{pmatrix}$$

Exercise 11.1

1. (a) $[(-2/\sqrt{x})]/(1 - \sqrt{x})^3$
 (b) $e^{-x}/\sqrt{(1 - 2e^{-x})}$
 (c) $2(\cos x - 2 \sin 2x)(\sin x + \cos 2x)$
 (d) $1/[2(1+x)\sqrt{(1 + \ln(1+x))}]$
 (e) $-\sec x e^{-\tan x}$
 (f) $\pi \sin 2(1 + \pi x)$
 (g) $(-\pi \sin \pi x)/(1 + \cos \pi x)$
 (h) $-2(x - 1) e^{-(x-1)^2}$
 (i) $-8x/(1 - x)^2$
 (j) $(-\operatorname{cosec}(1 + \sqrt{x})/(-2\sqrt{x}))$
 (k) $e^{1+x} \sec(e^{1+x}) \tan(e^{1+x})$
 (l) $2x 2^{1+x^2} \ln 2$
2. (a) $2x \sin \omega x + \omega x^2 \cos \omega x$
 (b) $(1/(2\sqrt{x}))e^{\cot x} - (\sqrt{x}) \operatorname{cosec} x e^{2 \cot x}$
 (c) $4(1 + 2x) \tan \omega x + 2\omega x (1 + 2x)^2 \sec^2 \omega x$
 (d) $2(x + 1) e^{(x+1)^2} \ln \cos^2 x - 2e^{(x+1)^2} \tan x$
 (e) $(\sin x \sin \pi x) e^{2 - \cos x} + (\pi \sin 2\pi x) e^{-\cos x}$
 (f) $-2 \sin 2x \sin^2 x + (\sin 4x)/2$
 (g) $1/x + (\sec x)/(\tan x)$
 (h) $-2x e^{-x^2} (\ln x + 2x) + e^{-x^2} (1/x + 2)$
 (i) $x \ln(1 + e^x) + (x^2 e^x)/(2(1 + e^x))$
 (j) $2/x - 1/(1 + x)$
 (k) $e^{1+x} [\ln 2x - \ln(1 - x)]$
 $+ e^{1+x} (1/x + 1/(1 - x))$
 (l) $2x [\ln x - 2x - 2 \ln(1 + x)]$
 $+ x^2 [1/x - 2 - 2/(1 + x)]$
3. (a) $\frac{2x(1 - 2x) + 2(1 + x^2)}{(1 - 2x)^2}$
 (b) $\frac{1}{2\sqrt{x}(1 + \sqrt{x})^2}$
 (c) $2/(1 + \cos 2x)$
 (d) $\frac{2e^{2x} + 4}{(1 + 2e^{-2x})^2}$
 (e) $\frac{e^{-2\cos x} (2 \sin x - 4e^{\sin x} \sin x + 2e^{\sin x} \cos x)}{(1 - 2e^{\sin x})^2}$

3. (f) $[1 - \ln(1 + 2x)]/(1 + 2x)^2$
 (g) $\frac{2x(1 + e^{2x})\ln(1 + e^{2x}) - 2x^2 e^{2x}}{(1 + e^{2x})[\ln(1 + e^{2x})]^2}$
 (h) $\frac{e^{\sin x}(\cos x + e^{-\cos x} \cos x - e^{-\cos x} \sin x)}{(1 + e^{-\cos x})^2}$
 (i) $\frac{e^x}{(1 + e^x)^2} \sec^2 \frac{e^x}{(1 + e^x)}$
 (j) $\frac{-e^{\left(\frac{x}{x-1}\right)}}{(x-1)^2}$ (k) $\frac{-e^{\left(\frac{\cos x}{1+\sin x}\right)}}{(1 + \sin x)}$
 (l) $\frac{x(1 - \ln(1 + x^2))}{(1 + x)^2}$
4. (a) $\frac{3}{2\sqrt{x}} + 3 + \frac{3\sqrt{x}}{2}, \frac{-3}{4x^{3/2}} + \frac{3}{4\sqrt{x}}$
 (b) $\frac{e^{-x}}{2}(1 - e^{-x})^{-1/2}, \frac{-e^{-x}}{4}(1 - e^{-x})^{-3/2}(2 - e^{-x})$
 (c) $-2 \sin 4x, -8 \cos 4x$
 (d) $1/(1 + x), -1/(1 + x)^2$
 (e) $-e^{-\sin x} \cos x, e^{-\sin x} (\sin x + \cos x)^2$
 (f) $2 \tan x + 2 \tan^2 x, 2 + 8 \tan x + 6 \tan^2 x$
5. $4(x + 2) \cos x - (x^2 + 4x - 1) \sin x$

Exercise 11.2

1. (a) $6(x - 1)$ (b) $-2/x^3$
 (c) $(x - 1)/(2x^{3/2})$ (d) $\pm 1/\sqrt{x}$
2. (a) $(2t^2 - 1)/(t^2 + 1)$ (b) $(6t - 1)/(6t^2 + 1)$
 (c) $(t^2 + 1)/(t^2 - 1)$ (d) $(1 - t)/(1 - 2t)^2$
3. (a) $\pm x/\sqrt[2/3]{(4 - x^2)}$ (b) $\pm (x - 2)/\sqrt[1/3]{(4x - x^2)}$
 (c) $\pm[\sqrt[1/3]{(1 - x^2)}]/x$ (d) $-4x$

Exercise 11.3

1. (a) $-(2x + 3y)/(3x + 2y)$
 (b) $(2x - y)/(x + 2y)$
 (c) $(1 - y - 2xy)/(x + 2xy)$
 (d) $-(y + 4x^{3/2} y^{1/2})/(x + 4y^{3/2} x^{1/2})$
 (e) $-(e^y + ye^x)/(e^x + xe^y - 1)$
 (f) $y(4 - y - 2x \ln y)/(x^2 + xy)$
2. (a) $[2x \cos y + y \cos x]/[x^2 \sin y - \sin x]$
 (b) $\frac{\sin y \sin x - e^{\cos y}}{\cos y \cos x - x \sin y e^{\cos y}}$

2. (c) $\frac{3 + y \sin xy - 4 \tan y}{4x \sec^2 y - x \sin xy}$
 (d) $y/[e^{y/2} \sin(e^{y/2}) - x - \cot(y)]$
 (e) $-y/[x(1 + y e^{y/2})]$
 (f) $-(y^2 + 2y - 1)/[x(y + 1)]$
3. (a) $2x(dx/dt) + 2y(dy/dt)$
 (b) $\cos x(dx/dt) - \sin y(dy/dt)$
 (c) $-2e^{-2x}(dx/dt) + 0.05e^{0.05y}(dy/dt)$
 (d) $2xy(dx/dt) + x^2(dy/dt)$
 (e) $e^{-x} \sin \pi y(dx/dt) + \pi e^{-x} \cos \pi y(dy/dt)$
 (f) $\ln(1 + \tan y)(dx/dt) + [(x \sec^2 y)/(1 + \tan y)](dy/dt)$
 (g) $(1/y)(dx/dt) - (x/y)(dy/dt)$
 (h) $e^{2x}(1 - e^{-y})[2(dx/dt) + e^{-y}(dy/dt)]/(1 + e^{-y})^2$
 (i) $[(1 + \cos x) \cos y(dy/dt) + \sin x \sin y(dx/dt)]/(1 + \cos x)^2$

Exercise 11.4

1. (a) $2^x \ln(2)$ (b) $x^x [1 + \ln x]$
 (c) $2^{2x+1} \ln 2$ (d) $2x^{\ln(x)-1} \ln(x)$
 (e) $x^{\sin x} \{\cos(x) \ln(x) + [\sin(x)]/x\}$
 (f) $x^{\cos x} \{[\cos(x)]/x - \sin(x) \ln(x)\}$
 (g) $(1 + x)^x \{\ln(1 + x) + x/(1 + x)\}$
 (h) $-(1/x)^x [\ln(x) + 1]$
 (i) $[(\ln x)^{\ln x}][\ln(\ln(x) + 1)]/x$
2. (a) $2/(1 - x)^2$
 (b) $(x^4 + 3x^3 + 2x^2)/(1 - x)^{3/2}$
 (c) $(-x^4 + 2x^3 + 3x^2 - 2x + 1)/(1 - x)^{3/2}$
 (d) $(1 + x)(-2x^2 + 6x + 4)/(1 - 2x)^{3/2}$
 (e) $-2(1 - 2x)(8 - x)/(x + 2)$
 (f) $-(2 + \sqrt{x})(\sqrt{x} + 8)/[2\sqrt{x}(\sqrt{x} - 1)^4]$
 (g) $1/[(2x)^{1/2} (1 - 3x)^{3/2}]$
 (h) $1/[2(1 + x)^{1/2} (3x + 4)^{3/2}]$
 (i) $2x/[(1 + x)^{1/2} (1 - x)^{3/2}]$

Exercise 12.1

1. (a) $y = -x + 1$
 (b) $y = -2x/3 + 2/3; y = 2x/3 - 11/3$
 (c) $y = -x/2 + \pi/3$
 (d) $y = -x/2 - 3/2$
2. $y = -x + 1$ 3. $y = -12x + 3$
4. $(-2, 0)$ & $(2, -2)$ 5. $(2, -2)$ & $(-2, 2)$
6. $(1, -1)$ & $(-1, 1)$

7. $(1, 2n\pi), (-1, (2n+1)\pi)$
 & $(0, (4n+1)\pi/2)$ for $n \in \mathbb{Z}$
 8. (a) $y = -2$ (b) $x = -2$
 9. (a) $x = -2$ (b) $y = 0, y = 3/2$
 10. (a) $x = \pm \pi\sqrt{-(4n+1)}$ for $n \in \mathbb{Z}^-$
 (b) $y = -0.7391$

Exercise 12.2

1. 0.1 2. -2.5
 3. (a) $3/20$ (b) $(\sqrt{3})/10$
 4. (a) $-\frac{\pi\sqrt{3}}{2^{-1}}$ (b) $-\frac{6\sqrt{3}}{\pi}$
 5. 2 cm s^{-1} ; 0.8 cms^{-1}
 6. 0.031 mms^{-1} ; 0.016 mm s^{-1}
 7. 0.0025 m/min
 8. (a) $4\pi \text{ cm s}^{-1}$ (b) $8\pi \text{ cm s}^{-1}$
 9. 0.032 cms^{-1} ; 63.08 cm s^{-1}
 10. 0.10 m/min 11. -1 cm/min
 12. 0.0019 cm/min 13. -0.031 ms^{-1}
 14. 0.052 ms^{-1} 15. 0.18 ms^{-1}
 16. -22.86 m/min 17. $1/100 \text{ rad/sec.}^{-1}$
 18. $-1/250 \text{ rad/sec}$ 19. 2.4 cms^{-1}
 20. 50.27 cm/min 21. 54.66 km/min
 22. 11.17 ms^{-1} 23. -11.12 ms^{-1}
 24. 26.8 ms^{-1} 25. 0.96 cm/min

Exercise 13.1

1. $x \sin(x) + \cos(x) + C$
 2. $e^x [\sin(x) + \cos(x)]/2 + C$
 3. $2[x \ln(x) - x] + C$
 4. $x e^x - e^x + x^2/2 + C$
 5. $\frac{1}{2} e^{x^2} + C$ 6. $-e^{\cos(x)} + C$
 7. $-\frac{1}{2} [e^x (\sin(x) + \cos(x))] + C$
 8. $-(x+2x+2)e^{-x} + C$
 9. $-e^{-x}(1+x) - x^2/2 + C$
 10. $x^3/3 + x^2 [2 \ln(x) - 1]/4 + C$
 11. (a) $(\sqrt{x+1})^2 + C$ (b) $e^x + C$
 (c) $(\sqrt{x+1})^2 + e^x + C$ (d) $x^2/2 + (\sqrt{x+1})^2 + C$

Exercise 13.2

1. (a) $4\sqrt{x} + C$ (b) $3(\sqrt{x})/2 + C$
 (c) $-1/[4(2t+1)^2] + C$
 (d) $-(1-4x)^{1/2} + C$ (e) $(x+1)^4/4 + C$
 (f) $-1/x - 2/x^2 - 4/(3x^3) + C$
 (g) $x^7/7 + x^4/2 + x + C$
 (h) $t^7/7 - 3t^5/5 + t^3 - t + C$
 2. (a) $(1+x)^{2/4} + C$ (b) $-(1-2x)^{2/3/2} + C$

2. (c) $-(1-x)^{3-3}/3 + C$ (d) $4(1+x)^{3/2} + C$
 (e) $(2x+x^2)^4/8 + C$ (f) $-(2x-x^2)^2/2 + C$
 (g) $(1-1/x)^4/4 + C$ (h) $2(1+\sqrt{x})^5/5 + C$
 3. (a) $8e^{0.05x} + C$ (b) $-5e^{-0.1x} + C$
 (c) $(e^{2x})/2 + C$ (d) $-(e^{-6x})/3 + C$
 (e) $2e^{2x} + 4e^x + x + C$
 (f) $x - e^x + C$
 (g) $(e^{2x})/2 + 4x - 2e^{-2x} + C$
 (h) $-(e^{-2x})/2 + 4x - 4e^{-x} + C$
 4. (a) $\frac{e^{2x^2}}{16} + C$ (b) $\frac{-3e^{-x^2}}{4} + C$
 (c) $\frac{e^{1+x^2}}{2} + C$ (d) $e^{x^2-4} + C$
 (e) $\frac{e^{x^2+2x}}{2} + C$ (f) $\frac{(1+e^x)^5}{5} + C$
 (g) $(1/3)(e^{2x} - 1)^{3/2} + C$
 (h) $(-1/8)(1+2e^x)^{-4} + C$

Exercise 13.3

1. (a) $(2/3) \ln|1+3x| + C$
 (b) $(-4/5) \ln|2-5x| + C$
 (c) $x^2/8 - x + \ln|x| + C$
 (d) $-1/(3x) + 2 \ln|x| + 4x + (4x^2)/3 + C$
 (e) $x - 2 \ln|x| - 1/x + C$
 (f) $x + 3 \ln|x| - 3/x - 1/(2x^2) + C$
 (g) $(-7/6) \ln|1-3x^2| + C$
 (h) $(-1/2) \ln|2x^3 - 1| + C$
 2. (a) $(-1/2) \ln|x^2 - 8x| + C$
 (b) $3 \ln|x^2 + 3x| + C$
 (c) $\ln|1+x| + C$
 (d) $(-5/4) \ln|1+2e^{-2x}| + C$
 (e) $(3/4) \ln|1+2e^{x^2}| + C$
 (f) $(1/2) \ln|e^{2x} + e^{-2x}| + C$
 (g) $6 \ln|1+\sqrt{x}| + C$
 (h) $(-3/2) \ln|1+1/x| + C$
 (i) $\ln|\ln x| + C$
 3. (a) $x^2 + C$ (b) $x^6/3 + C$
 (c) $2x^6/3 + C$ (d) $\sqrt{x+x^2} + C$

Exercise 13.4

- (a) $(\sin 2x)/2 + C$ (b) $\cos(1 - 2t) + C$
 (c) $(\tan(1 + 2x))/2 + C$
 (d) $(-1/\pi) \ln |\cos \pi x| + C$
 (e) $(-3/2) \cot(4t/3) + C$
 (f) $(1/2) \ln |\sin 3x| + C$
 (g) $-((\sqrt{2})/\pi) \cot(1 + \pi t) + C$
 (h) $(5/3\pi) \tan(\pi x + 1) + x/3 + C$
 (i) $(1/(3\pi)) \cot(\pi x) + x/3 + C$
- (a) $(-1/2) \cos^2 2x + C$
 (b) $(-1/4) \sin^2(1 - x) + C$
 (c) $(3/2) \tan^4 x + C$
 (d) $(-1/4) \cot^4 x + C$
 (e) $(1 + \sin x)/4 + C$
 (f) $(1 - 2 \cos 2x)^{3/2}/6 + C$
 (g) $-(1 + \cot x)/4 + C$
 (h) $2(1 + \tan x)^{1/2} + C$
 (i) $(1 + \cot 2x)^{-3}/6 + C$
- (a) $(-1/(2\pi)) \ln |1 - \sin 2\pi x| + C$
 (b) $(-1/2) \ln |1 + \cos(2x + 1)| + C$
 (c) $(-1/2) \ln |\cos 2x - \sin 2\pi x| + C$
 (d) $(1/2) \ln |1 + \tan 2x| + C$
 (e) $(-3/4) \ln |1 + 2 \cot 2x| + C$
 (f) $(-1/2) \ln |1 - 2e^{\sin x}| + C$
- (a) $(1/4) \sin^2 2x + C$
 (b) $(-1/3) \cos 2x + C$
 (c) $(1/2) \sin 2x + C$
 (d) $(1/4) \sin 4x + C$
 (e) $\ln |\sin 2x| + C$
 (f) $(1/2) \tan x + C$
- (a) $(1/2) \tan 2x + C$
 (b) $(1/10) \tan^2 2x + C$
 (c) $(2/3)(1 + \tan x)^{3/2} + C$
 (d) $(-1/4)(1 + 2 \tan x)^{-2} + C$
 (e) $(\pi + \tan 2x)^{1/2} + C$
 (f) $(-1/2) \ln |3 - 2 \tan x| + C$
- (a) $(-1/2) \cot^2 2x + C$
 (b) $(-1/(5\pi)) \cot^3 \pi x + C$
 (c) $(-2/3)(1 + \cot x)^{3/2} + C$
 (d) $(-1/3)(1 - \cot x)^{-3} + C$
 (e) $(-2/3)(4 + 3 \cot x)^{1/2} + C$
 (f) $-\ln |2 + \cot x| + C$
- (a) $-\cos x + C$ (b) $(\sin 3x)/3 + C$
 (c) $(-1/\pi) \cos(\pi x + \pi/6) + C$
 (d) $(-1/3) \ln |\cos 3x| + C$

- (a) $\cos x + C$ (b) $(\sin^2 x)/2 + C$
 (c) $-\ln |\cos \sqrt{x}| + C$

Exercise 13.5

- (a) $[x - (\sin 8x)/8]/2 + C$
 (b) $(1/4)[3x/2 - (1/\pi) \sin(2\pi x) + (1/8\pi) \sin(4\pi x)] + C$
 (c) $(1/2)\{t - (1/4) \sin[2(1 - 2t)]\} + C$
 (d) $(1/2)\{x + [\sin(4\pi x)]/(4\pi)\} + C$
 (e) $[-1/(2\pi)]\{\cos(2\pi t) - [\cos^2(2\pi t)]/3\} + C$
 (f) $(2/\pi)\{\sin(\pi x/2) - [\sin^3(\pi x/2)]/3\} + C$
 (g) $(-1/\pi)\{\cos(\pi t) - (2/3) \cos^3(\pi t) + (1/5) \cos^5(\pi t)\} + C$
 (h) $(-1/\pi)\{\sin(1 - \pi x) - (1/3) \sin^3(1 - \pi x)\} + C$
 (i) $(2/\pi)\{\cos[1 - (\pi x/2)] - (2/3) \cos^3[1 - (\pi x/2)] + (1/5) \cos^5[1 - (\pi x/2)]\} + C$
- (a) $[1/(2\pi)] \sin(\pi t) + C$
 or $[-1/(4\pi)] \cos(2\pi t) + C$
 (b) $[2/(3\pi)] \sin^3(\pi x/2) + C$
 (c) $[-1/(9\pi)] \cos^6(3\pi x) + C$
 (d) $[1/(3\pi)] \sin^3(\pi x) + C$
 (e) $(1/8)[x - (\sin 2x)/2] + C$
 (f) $(1/\pi)\{[\sin^3(\pi t)]/3 - [\sin^5(\pi t)]/5\} + C$
 (g) $(-1/2)\{[\cos^3(2x)]/3 - [\cos^5(2x)]/5\} + C$
 (h) $1/\cos(x) + \cos(x) + C$
 (i) $-1/\sin(x) - \sin(x) + C$

Exercise 13.6

- (a) $(1 + 2x)^7/14 + C$
 (b) $-(1 - 2t)^{3/2}/3 + C$
 (c) $4(x + 1)^{3/2}/3 + C$
 (d) $4(1 + x^2)^{3/2}/9 + C$
 (e) $-(9 - 4x^2)^{1/2}/2 + C$
 (f) $4(x - 8)^{1/2}/3 + C$
- (a) $4(4 + \sqrt{x})^{5/3}/5 - 16(4 + \sqrt{x})^{3/2}/3 + C$
 (b) $2(1 + x)^{5/2}/5 - 2(1 + x)^{3/2}/3 + C$
 (c) $(-2/3)(1 - x)^{3/2} + (4/5)(1 - x)^{5/2} - (2/7)(1 - x)^{7/2} + C$
 (d) $(1/32)[2(1 + 2x)^{11/2}/11 + 8(1 + 2x)^{9/2}/9 + 12(1 + 2x)^{7/2}/7 + 8(1 + 2x)^{5/2}/5 + 2(1 + 2x)^{3/2}/3] + C$
 (e) $(1/4)[(2x + 1) - \ln |2x + 1|] + C$
 (f) $(x + 2) - 4 \ln |x + 2| - 5/(x + 2) + C$
 (g) $4(4 + x)^{3/2}/3 - 16(4 + x)^{1/2} + C$
 (h) $2(2 + \sqrt{x} - 2 \ln |2 + \sqrt{x}|) + C$

3. (a) $\sin x^2 + C$
 (b) $(-3 \cos(x^2 + 1))/2 + C$
 (c) $(\tan(2x))^2/4 + C$ (d) $-2 \ln|\cos x^2| + C$
 (e) $(\sin(2x^2 + 1))/4 + C$
 (f) $(-\cos(2 + x^3))/3 + C$
4. (a) $(1 + \sqrt{x})^4/2 + C$ (b) $(1 + \ln|x|)^3/3 + C$
 (c) $[2x + 3 + \ln|2x + 3|]/4 + C$
 (d) $1/(1-x) + 3 \ln|1-x| - (1-x) + C$
 (e) $2(x+9)^{3/2}/3 - 16(x+9)^{1/2} + C$
 (f) $2[(1 + \sqrt{x})^3/2 - 3(1 + \sqrt{x})^2/2 + 3(1 + \sqrt{x}) - \ln|1 + \sqrt{x}|] + C$
 (g) $(-1/2) \cos(x^2) + C$
 (h) $2 \sin(\sqrt{x}) + C$ (i) $\cos(1/x) + C$
 (j) $-\sin(e^{-x}) + C$ (k) $(1/2) \tan(x^2) + C$
 (l) $-1/[3 \tan(x^3)] + C$

Exercise 13.7

1. (a) $-2(4-x)^{2/2} + C$
 (b) $(-1/4)(9-4t)^{-1} + C$
 (c) $\tan^{-1} x + C$
 (d) $(1/15) \tan^{-1}(3x/5) + C$
2. (a) $-\cos^{-1}(x/2) + C$
 (b) $(-1/2) \cos^{-1}(2x/3) + C$
 (c) $[\sin^{-1} x + x \sqrt{(1-x^2)}]/2 + C$
 (d) $-2 \cos^{-1}(x/2) + (x \sqrt{(4-x^2)})/4 + C$
 (e) $-\sqrt{(1-x^2)} - \sin^{-1} x + C$
 (f) $-2\sqrt{(16-x^2)} - \cos^{-1}(x/4) + C$
3. (a) $[\tan x]/3 + [\tan x]^{1/2}/5 + C$
 (b) $(2/3)[3 \tan x + 2]^{1/2} + C$

Exercise 13.8

1. (a) $x - 2 \ln|x+2| + C$
 (b) $x/2 - (5/4) \ln|2x+1| + C$
 (c) $-3x/2 - (1/4) \ln|1-2x| + C$
2. (a) $(1/2) \ln|(x-1)/(x+1)| + C$
 (b) $(3/14) \ln|2x+1| + (2/7) \ln|x-3| + C$
 (c) $(-13/24) \ln|3x+2| - (9/8) \ln|2-x| + C$
 (d) $(-2/3) \ln|2x-1| + (5/3) \ln|x-2| + C$
 (e) $x - (3/5) \ln|x+2| + (8/5) \ln|x-3| + C$
 (f) $(1/2) \ln|x+1| + (1/10) \ln|x-3| - (3/5) \ln|x+2| + C$
3. (a) $\ln|x/(x-1)| - 2/(x-1) + C$
 (b) $3 \ln|x| + 1/x - 3 \ln|x+1| + C$

3. (c) $3 \ln|x+1| + 1/(x+1) - 3 \ln|x+2| + C$
 (d) $x - 1/[2(x-1)] + (5/4) \ln|x-1| - (1/4) \ln|x+1| + C$
 (e) $3/[4(x+2)] + (3/16) \ln|x-2| + (13/16) \ln|x+2| + C$
 (f) $x - 28/[3(x-3)] + (1/9) \ln|x| + (53/9) \ln|x-3| + C$
4. (a) $-\ln|x+1| + (1/2) \ln|x^2+1| + C$
 (b) $-2 \ln|x+1| + \ln|x^2+x+1| + C$
 (c) $\ln|x-1| + \ln|x^2+x-1| + C$

Exercise 14.1

1. (a) $(1/2) \ln(3/2)$ (b) $-5 \ln 2 + 3 \ln 3$
 (c) $4 \ln 3 - 7 \ln 2$
2. (a) $1 + 5 \ln 2 - 4 \ln 3$ (b) $1 + (3/2) \ln 3 - \ln 2$
 (c) $-5/2 + 3 \ln 2 + 2 \ln 3$
3. (a) $-1/2 - 3 \ln 2 + 2 \ln 3$
 (b) $1/8 + (1/4) \ln 2 - (1/4) \ln 3$
 (c) $5/4 + (3/4) \ln 2 + (1/4) \ln 3$
4. (a) $3 \ln 2$ (b) $-4 \ln 2$ (c) $2 \ln 3 - 3 \ln 2$

Exercise 14.2

1. (a) $2[-(2\sqrt{3})/5 + (16\sqrt{2})/15]$
 (b) $2[8 \ln 2 - 4 \ln 3 - 1]$ (c) $2 - \ln 3$
 (d) $-26/3 + (28\sqrt{2})/3$
2. (a) 2 (b) 1 (c) 1/2
3. (a) $\pi/12$ (b) $\pi/18$ (c) $\pi/8$

Exercise 14.3

1. (a) 8/3 (b) 16/3 (c) 8 (d) 1/3
2. (a) 9/8 (b) 2 (c) $2(\sqrt{2}-1)$
 (d) $e^2/2 + 1/e - 3/2$
3. (a) 1/6 (b) 9/2 (c) 13/6 (d) 13/6
4. (a) 2 (b) 9/2 (c) $5/3 - 2 \ln 2$
 (d) $8/3 - 2 \ln 3 + 2 \ln 2$
5. (a) $\pi/8 + (\sqrt{3})/2 - 1$ (b) $(\sqrt{3})/2 + \pi/2$
6. $(1/2)[5 + \ln(45/64)]$
7. 4 8. $8 - \pi/3$ 9. $9\pi/4$
10. (a) 2.9540 (b) 9.8633
 (c) 4.1045 (d) 18.6768
11. (a) 0.6321 (b) 0.8415
 (c) 0.7372 (d) 1.8887
12. (a) 32/3 (b) 9/2
 (c) $(32\sqrt{2})/3$ (d) 16/5
13. (a) $3/4 - 2b + 3b^2/2 - b^4/4$
 (b) $b^4/4 - 3b^2/2 + 2b + 51/4$
 (c) $b^4/4 - 3b^2/2 + 2b + 51/4$

Exercise 14.4

- (a) $16\pi/15$ (b) $512\pi/15$ (c) $16\pi/15$
(d) $\pi/105$ (e) π (f) π
- (a) 3.35 (b) 342.96 (c) 154.57
(d) 17.40 (e) 35.02 (f) 2.47
(g) 9.42 (h) 3.35
- (a) 1.57 (b) 7.33 (c) 0.71
(d) 9.07 (e) 0.52 (f) 7.87
(g) 113.10 (h) 201.06
- (a) 64.72 (b) 37.70 (c) 724.10
(d) 3.14 (e) 40.74

Exercise 15.1

- (a) 1.09 error 0.7%
(b) 1.069 error -1.2%
(c) 1.0807 error -0.16%
- (a) 9.0009 error 0.01%
(b) -68.3344 error 0.0015%
- (a) 0.7469 (b) 0.3103
- (a) 8.7733 (b) 1.4558
- (a) 6.7965 (b) 1.4035

Exercise 16.1

- (a) $y = \ln|x^2 + 1| - 4$
(b) $y = (-1/2)\ln|(x-1)(x+1)^3| + 2$
(c) $y = -4\ln|x+1| + 5\ln|x+2| - 4\ln 2$
(d) $y = -\sin^{-1}(x)$ (e) $y = \tan^{-1}(2x)$
(f) $y = \sin^{-1}(x) + x\sqrt{1-x^2}$
- $y = -2\pi x + \sin(2\pi x)$ 3. $y = \sin^2(x) - 2$
- $y = -12\cos(x) + 4\cos^3(x) + 4$
- $y = 6(x+1)^{5/2} - 10(x+1)^{3/2} + 2$
- $y = -2x + 2\ln|2x+1| + 2$

Exercise 16.2

- (a) $y = 100e^{0.02t}$ (b) $y = 50e^{3t}$
(c) $y = 202e^t - 2$ (d) $y = [4 + 1196e^{-3t}]^3$
(e) $y = [-1 + 501e^{-10t}]^5$
(h) $y = (1/2)(1 + 399e^{-20t})$
- $dy/dt = 0.03y$ with $y(0) = 100\,000$
- $dP/dt = P/3$ with $P(0) = 100\,000$
- 4 620 981 yrs
- 194.34 yrs, 839.91 yrs
- 1.33 rads 7. 0.46g
- (a) 2.23% (b) 0.288%
- (a) $k = 0.067\,29$ (b) 22.9 min
- (a) $k = 0.030\,31$ (b) 81.3 min
- $I = 2(1 - e^{-4t})$ 12. (b) 69.31 min
- (a) $a = 80, b = 25$
(b) $m = 2\,000, n = 1\,500, k = 1/25$
(c) 1.72 min (d) $500 \leq Q < 2\,000$

- (a) $a = 16, b = 62.5$
(b) $m = 1\,000, n = 9\,000, k = -2/125$
(c) 111.98 min (d) $1\,000 < Q \leq 10\,000$

Exercise 16.3

- (a) $dP/dt = 0.2P(1 - P/1000)$
 $= 0.0002P(1000 - P)$
(b) $dP/dt = 0.1P(1 - P/500)$
 $= 0.0002P(500 - P)$
(c) $dP/dt = 0.5P(1 - P/10\,000)$
 $= 0.000\,05P(10\,000 - P)$
(d) $dP/dt = 0.25P(1 - P/5000)$
 $= 0.000\,05P(5000 - P)$
- (a) $P = 1000/(1 + 19e^{-2t})$
(b) $P = 100/(1 + 4e^{-0.05t})$
(c) $C = 50/(1 + 9e^{-0.1t})$
(d) $\theta = 1000/(1 + 24e^{-0.05t})$
- (a) $y = 200/(1 + e^{-4t})$
(b) $P = 100/(1 + 9e^{-t})$
(c) $P = 50/(1 + 0.25e^{-0.2t})$
(d) $x = 100/(1 + 4e^{-0.5t})$
- (a) $P = 100/(1 + 3e^{-0.05t})$
(b) 21.97 years
- (a) $P = 20\,000/(1 + 99e^{-0.08t})$
(b) 181.2 years
- (a) $P = 2000/(1 + 199e^{-10t})$
(b) 3 weeks
- 394 minutes to reach 49.9g/L
- 11.6 days
- 15.2 hours
- Yes, if the company is able to attract about 338 families on its opening day.
- $k = 0.1099$
- $k = 0.06592$
- $dP/dt = 0.1P(1 - P/1000)$
- $y = (4e^{2t} - 3)/(3 - 2e^{2t})$

Exercise 16.4

- (a) $y = \ln|x| + x^2/2 + A$
(b) $y = A(x-1) - 1$
(c) $y = \pm\sqrt{(1 - Ae^{\cos x})/x^2}$
(d) $y = Ae^{\cos x}$
- (a) $y = \sqrt{e^x + 3}$
(b) $y = \ln[(1+x)^2/2]$
(c) $y^2/2 + y = \ln(x+1) + 3/2$
(d) $y = 3xe^{x-1} - 1$ (e) $y = x$
(f) $y = \pm\sqrt{(1/\sin x - 1)}$

Exercise 16.5

1. (a) Min (1, 1); y-intercept \approx (0, 1.7)

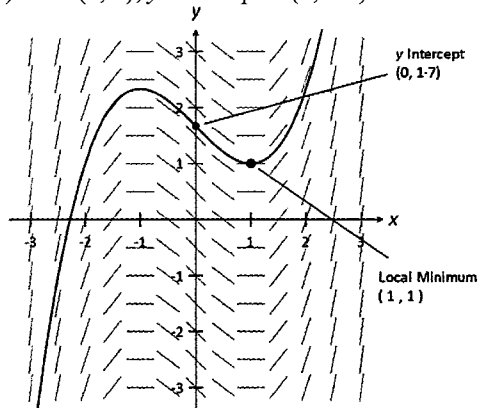

(b) Min (1, -1); y-intercept \approx (0, -0.3)

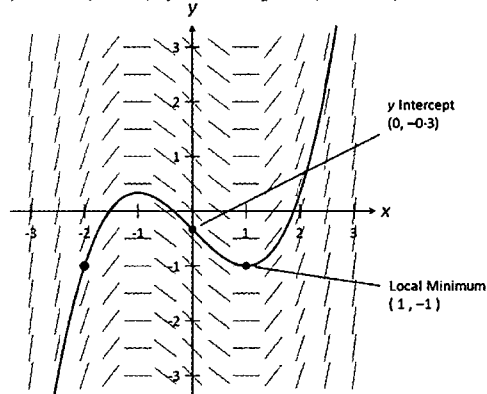

2. (a) (i) $y(10) \approx 5$

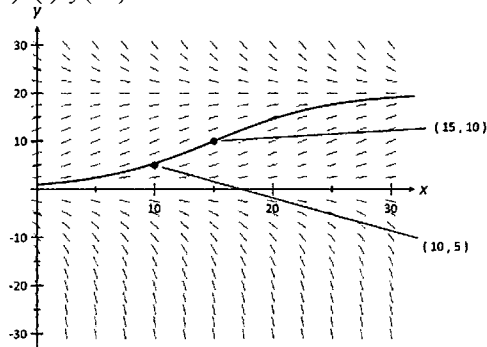

(ii) $y(10) \approx -1$

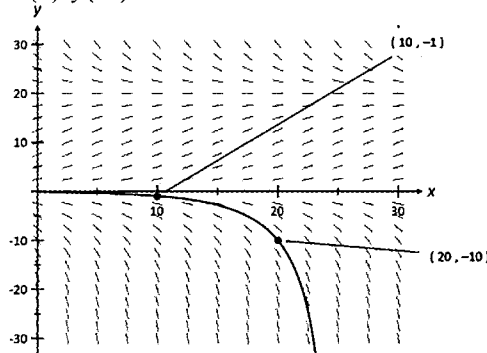

(b) $y = 0, y = 20$

3. (a) (i) Curve does not have an x-intercept.

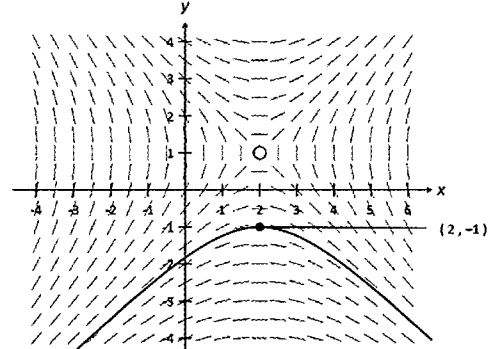

(ii) When $y = 0, x \approx -0.5$.

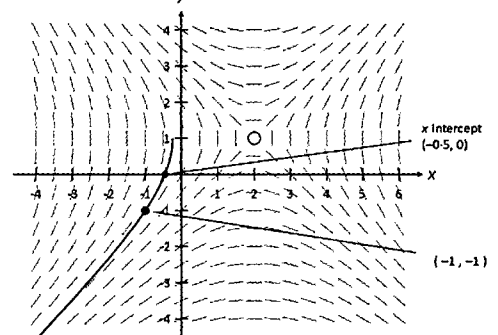

(b) $y = x - 1$ where $x \neq 2 \cap y \neq 1$

4. Slope field has zero gradient for $x = 2$ and infinite gradient for $y = 1$; hence C.

Isocline with gradient -2 is $y = -x/2 + 2$

5. (a)

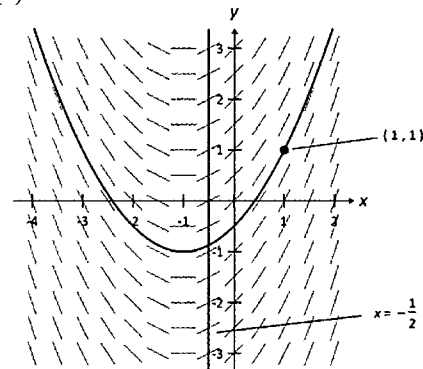

(b) Slope field has zero gradient for $x = -1$, hence, A.

(c) $x = -1/2$.

6. (a) $y \approx 0.3$

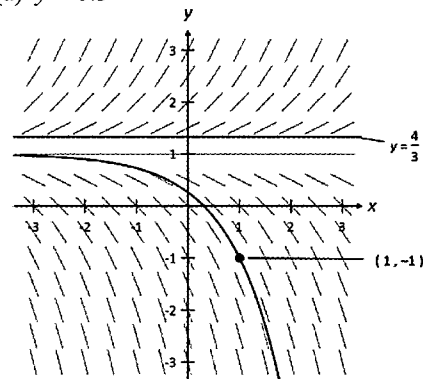

(b) C

(c) $y = 4/3$

7. (a) $dy/dx = 1$ (b) $dy/dx = -2$
 (c) $dy/dx = x$ (d) $dy/dx = -y$
 (e) $dy/dx = xy$ (f) $dy/dx = (x-1)/y$

Exercise 17.1

1. (a) -0.35 m (b) 0.79 s
 (c) 3.64 m (d) 3.99 m⁻¹
 2. (a) $3\pi/4$ s, -14.92 ms (b) 4.81 ms⁻¹
 3. (a) $0.4637 + (n\pi/2)$ sec. $n = 0, 1, 2, 3, \dots$
 4. (a) -8 ms (b) 2 ms⁻¹
 5. (a) $\pi/3$ s (c) $0, \pi/2, \pi$ s
 6. (a) 8 ms⁻¹ (b) $16/3$ m (c) 2 ms⁻¹
 7. (a) 0 (b) 1 sec
 8. (a) $x = -2 + 2e^{2t}$ (b) $a = 8e^{2t}$
 9. (a) -21 ms⁻² (b) $0, 2$ m
 10. (a) 4 ms⁻¹ (b) 1.76 ms⁻²
 11. (a) -2π ms⁻¹ (b) $1/2$ second
 12. (a) $9/2$ ms⁻¹ (b) $121/30$ m
 13. (a) $v = 4(1 - e^{-t})$ (b) 4 ms⁻¹
 14. (a) $v = -5(1 - e^{-2t})$ (b) -5 ms⁻¹
 15. (a) $v = (g/k)(1 - e^{-kt})$ (b) g/k
 16. $v = (5/4)\sqrt{(1 - e^{-32x})}$; $5/4$ ms⁻¹
 17. $v = 2(1 + e^{-100t})/(1 - e^{-100t})$; 2 ms⁻¹
 18. $v = \pm(1/k)\sqrt{(1 - e^{-2gk^2x})}$
 19. (a) $v = \sqrt{(16 - 9x)}$
 (b) $-4/3 \leq x \leq 4/3$; $0 \leq v \leq 4$
 20. (a) $v = 2\sqrt{(4x - x^2)}$
 (b) $0 \leq x \leq 4$; $0 \leq v \leq 4$
 21. (a) $v = 4/\sqrt{x}$ (b) $x = (6t + 64)^{2/3}$
 22. (a) $v = -2(x^2 + 1)$ (b) $x = -\tan(2t)$

Exercise 17.2

1. $x = 10 \sin 2t$ 2. $h = 5 \cos(5\pi t)$
 3. $y = 4 \sin(3t + \pi/6)$
 4. $Q = 10\sqrt{2} \sin(4\pi t - \pi/4)$
 5. (a) $x = 3 \sin(2\pi t)$ (b) 3 cm, 1 second
 (c) 6π cms⁻¹ (d) $0.05, 0.45$ seconds.
 6. (a) $x = 4 \cos(4\pi t)$ (b) 0
 (c) $\pm 8\pi\sqrt{3}$ cms⁻¹
 7. (a) $10 \sin(t + \pi/3)$ (b) $0 \leq \text{speed} \leq 10$
 (c) $\pm 5\sqrt{3}$ cm
 8. (a) 2π cms⁻¹ when $t = (2n + 1)$ sec. at $x = 0$
 (b) 0 cms⁻¹ when $t = 2n$ sec. at $x = \pm 4$ cm
 (c) 32 cm
 9. (a) $2\pi/15$ cms⁻¹; $2\pi^2/225$ cms⁻²
 (b) (i) $x = \pm\sqrt{3}$ cm (ii) $x = -1$ cm

10. (a) $\theta = 5 \sin(\pi t/12 - \pi/6)$
 (b) Min Temp 10 C at 8 pm
 (c) 16 hours
 11. (a) $h = 0.2 \cos(\pi t/14 + \pi/3)$
 (b) ± 0.14 m (c) 0.14 m
 12. (a) $x = 0.2 \sin(\pi t/14 + \pi/2) + 0.3$
 (b) (i) $-\pi/70$ (ii) 0 (c) 0.46 mg
 13. (a) (i) ± 2.27 C/hr (ii) ± 2.61 C/hr
 (b) 66.7% (c) 30 C
 14. (a) $h = 4 + 0.5 \sin(\pi t/6)$
 (b) 4.5 hours (c) 0.13 m/hour
 15. (a) $x = \pm 6\sqrt{3} \sin(\sqrt{2}t + \alpha)$
 (b) $12\sqrt{3}$ cms⁻²
 16. (b) 100 cm 17. (b) $\pm 2\pi\sqrt{105}$
 18. (a) 2 minutes, 10 (b) 2 minutes, 10
 19. (a) 2 seconds, 10 cm (b) $\pm 3\sqrt{11}$

Exercise 18.1

1. (a) $\langle 1/t, e^t, e^{-t} - te^{-t} \rangle$;
 $\langle -1/t, e, -2e^{-t} + te^{-t} \rangle$
 (b) $\langle 2 \cos 2t, -2 \sin 2t, 2(1 + \tan^2 2t) \rangle$;
 $\langle -4 \sin 2t, -4 \cos 2t, 8(1 + \tan^2 2t) \rangle$
 (c) $\langle -1/t^2, 1/(t+1)^2, -1/(t-1)^2 \rangle$;
 $\langle 2/t^3, -2/(t+1)^3, 2/(t-1)^3 \rangle$
 (d) $\langle -\pi \sin \pi t e^{\cos \pi t}, \pi \sin \pi t e^{-\cos \pi t},$
 $\frac{\pi \cos \pi t e^{\sin \pi t}}{\sin \pi t} \rangle$;
 $\langle \frac{\pi \cos \pi t e^{\cos \pi t}}{\cos \pi t}, -\frac{\pi \cos \pi t e^{-\cos \pi t}}{\cos \pi t},$
 $\frac{\pi \sin \pi t e^{-\cos \pi t}}{\sin \pi t} + \frac{\pi \cos \pi t e^{\cos \pi t}}{\sin \pi t} \rangle$
 2. $2 + 4t$; $t = -1/2$ 3. $0 \leq t \leq 2\pi$
 4. $0, \pi/2, \pi, 3\pi/2, 2\pi$ 5. $n = 4$
 6. $(2t + 4t^2)/[2\sqrt{(4 + t^2 + t^4)}]$
 7. $\{\sqrt{[5(t+1)^2 + 1]}/(t+1)\}$
 8. $4 + 6t$; 4 9. No solution
 10. $\pi/4, 3\pi/4, 5\pi/4, 7\pi/4$
 11. (a) $\langle a, 2 \sin t, 3 \cos t \rangle + c$; $\langle 0, 2, -3 \rangle$
 (b) $\langle t + \ln t, t - \ln t, \ln(1+t) \rangle + c$;
 $\langle 1 + \ln 2, 1 - \ln 2, \ln(3/2) \rangle$
 12. (a) $\sqrt{2}, \pi/2$ (b) $\sqrt{5}, 2.64$
 13. $\langle t - t^2 + 1, 4t + 1, t/2 \rangle$
 14. $\langle \cos \pi t, t, -1 + 2 \sin \pi t \rangle$
 15. $\langle -1, t, -t \rangle$
 16. $\langle -\sin \pi t, 1 - \cos \pi t, \pi t - \sin \pi t \rangle$
 17. 50

Exercise 18.2

1. (a) $\langle 10, 20, -8 \rangle$ (b) $\langle -8, 18, 34 \rangle$
 (c) $\langle 0, 0, 1 + \ln 2 \rangle$ (d) $\langle 0, 1, \pi/4 \rangle$

2. (a) $\langle 7, -4, 150 \rangle$ (b) $\langle -101, 99, 22 \rangle$
 (c) $\langle 1 + 6\pi, 1 + 2\pi, -2\pi \rangle$
 (d) $\langle 8\pi - 1, 1, 8\pi \rangle$
3. (a) $\langle 0, 0, 2 \rangle$; $\sqrt{10}$ ms⁻¹
 (b) 0 (d) 3.05 m
4. (b) 45° , 1 ms⁻¹ (c) $\langle 0, 0, 0 \rangle$
5. (a) 1 sec. (b) 0.54 m
 (c) 1 sec.
6. (a) Min of 0 cm when $t = 2n\pi$ sec.
 Max of $2\sqrt{2}$ cms⁻¹ when $t = (2n + 1)\pi$ sec.
 (b) $t = 0, \pi/2, \pi, 3\pi/2, 2\pi$ sec.
7. (b) $x - 1 = 2 - y = z - 1$
8. (a) 143.3° (b) 2 s, $\langle -16/3, 3, -2 \rangle$
 (c) $x = t/3 - 4t, y = t + 1, z = -2t + 2$
9. (a) $t = 2$ sec. at $\langle 0, -4, 8 \rangle$
 (b) 17.1
10. (a) $t = 1$ sec. at $\langle 2, 0, 0 \rangle$
 (b) 10.89

Exercise 18.3

1. P: $0i + 2j, x^2 + y^2 = 4$ clockwise;
 Q: $2i, x^2 + y^2 = 4$ anti-clockwise
 R: $2i, x^2 + y^2 = 4$ clockwise
2. (a) In the direction of the positive y -axis;
 $2\pi/3$ to the positive x -axis
 (b) $-\pi j$ (c) $1/2$
3. (a) 1
 (b) $x^2 + y^2 = 1/(16\pi^2)$; anti-clockwise
 (d) 1
4. $\mathbf{a} \cdot \mathbf{v} = 0$ for all t .
5. (a) $-i$ (b) $4\pi^2 i$
 (c) $t = (4n + 3)/8$ sec. for $n = 0, 1, 2, 3, \dots$
6. (a) j (b) $(-\pi/4)j$
 (c) $t = (6n + 2)/3$ sec. for $n = 0, 1, 2, 3, \dots$
7. (a) $t = n\pi$ sec. for $n = 0, 1, 2, 3, \dots$
 (b) $(n + 1/6)\pi$ sec. for $n = 0, 1, 2, 3, \dots$
 (c) $x^2 + (y - 2)^2 = 1$; clockwise
8. (a) $x^2 + y^2 = 1$; anti-clockwise
 (b) $\sqrt{2}i + \sqrt{2}j$ or $-\sqrt{2}i - \sqrt{2}j$
 (c) $t = (4n + 1)\pi/8$ sec. for $n = 0, 1, 2, 3, \dots$
9. No collision
10. (a) $0, \pi/2, \pi, 3\pi/2, 2\pi$
 (b) $\sqrt{(9 - 5 \cos t)}$
 (c) Max speed = 3 when $t = \pi/2$ at $(0, 2)$,
 and $t = 3\pi/2$ at $(0, -2)$;
 Min speed = 2 when $t = 0$ & 2π at $(3, 0)$
 and $t = \pi$ at $(-3, 0)$.

10. (d)

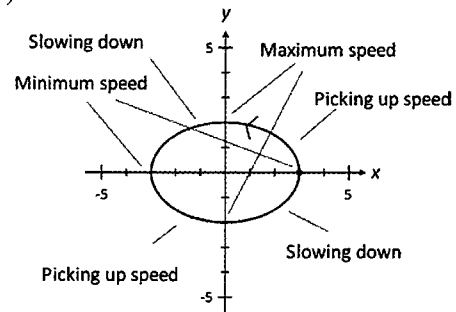

11. (a) 2π (b) $0, \pi/2, \pi, 3\pi/2, 2\pi$
 (c) At $(0, -4)$ when $t = (4n + 1)\pi/2, -3i$;
 At $(0, 4)$ when $t = (4n + 3)\pi/2, 3i$;
 (d) At $(3, 0)$ when $t = 2n\pi, -4j$;
 At $(-3, 0)$ when $t = (2n + 1)\pi, 4j$;
12. Period 2π ; $(x - 2)^2/9 + (y - 4)^2/25 = 1$
13. (a) 3 m (b) $\pm 12\pi i$
 (c) $t = n/2$ sec. for $n = 0, 1, 2, 3, \dots$
 (d) $t = (4n + 3)/8$ sec. for $n = 0, 1, 2, 3, \dots$
14. (a) $13\sqrt{2}/2$ cm
 (b) $x^2/25 + y^2/144 = 1$, clockwise
 (c) $\mathbf{r} = 5i$ for $t = 2n$ sec. for $n = 0, 1, 2, 3, \dots$
 $\mathbf{r} = -5i$ for $t = (2n + 1)$ sec. $n = 0, 1, 2, 3, \dots$
 (d) $t = (6n + 5)/6$ sec. for $n = 0, 1, 2, 3, \dots$
15. (a) Min 3 cms⁻¹, Max 4 cms⁻¹
 (b) $\pm 3i$ or $\pm 4j$
 (c) $t = n\pi$ sec. for $n = 0, 1, 2, 3, \dots$
16. (a) $(x - 1)^2/9 + (y - 2)^2/16 = 1$, anti-clockwise
 (b) $2\sqrt{5}$ cm or $\sqrt{37}$ cm or $2\sqrt{2}$ cm or $\sqrt{5}$ cm
17. $t = 0.64$ sec. at $(-2.4, 2.4)$, $\mathbf{v}_P = 1.8i + 3.2j$,
 $\mathbf{v}_Q = -1.2i - 0.8j$
18. When $t = \pi$ sec at $(1, -2)$; π radians

Exercise 18.4

1. (a) $30i + (30\sqrt{3} - 9.8t)j, 5.6^\circ$ to the horizontal
 (b) 95.6° (c) 10.60 sec., 318 m
2. (a) $106.07i + 61.97j$ (b) 20.7°
 (c) 1.93 s, 5.28 s (d) $y = x - 0.0392x^2$
3. (a) $\langle 20t, 20t - 4.9t^2 \rangle$
 (b) 45°
 (c) $\langle 17.25, 13.61 \rangle$ when $t = 0.86$ sec.
 (d) 93.7 m
4. (a) $\langle 25\sqrt{3}, 25 - 9.8t \rangle$;
 $\langle 25\sqrt{3}t, 25t - 4.9t^2 + 150 \rangle$
 (b) 8.64 sec.
 (c) -54° to the horizontal
 (d) 374.3 m
5. (a) $\langle 50, -9.8t \rangle$; $\langle 50t, (100 - 4.9t^2) \rangle$
 (b) 4.52 sec. (c) 225.88 m
 (d) -41.52° to the horizontal

6. (a) 13 ms^{-1} (b) 2.975 m
 (c) 2.75 m
 (d) 9.52 ms^{-1} , -58.31° to the horizontal
7. (a) $p = 30t_0$, $q = (30\sqrt{3})t_0 - 4.9t_0^2$
 (b) 7.07 sec.
 (c) 244.90 m up the slope of the hill
8. (a) $y = x \tan(20^\circ) - 4.9x^2/[400 \cos^2(20^\circ)]$
 or $y = -0.0139x^2 + 0.364x$
 (b) 18.89 m (c) 19.10 m
 (d) $t = 0 \text{ sec}$
9. (a) $\langle 8.09, -18.62 \rangle$ (b) 20.30 m
 (c) 20.34 m (d) 11.5°
10. (a) 4 sec. (b) $\langle 72, 17.6 \rangle$
11. $20 \text{ sec.}; 40\sqrt{5} \text{ m}$ 12. (b) $3/10$
13. (a) $\langle 3t - 2, 2t \rangle$ (b) $\langle 6t, 2 \rangle$
 (c) $0, 2/3$
14. (a) $\langle 20, 10 \rangle$ (b) 5
 (c) 106.89
15. (a) 48.01° above the horizontal
 (b) 26.9 m (c) 20 m when $t = 2 \text{ sec.}$
 (d) $\langle 32, 0 \rangle$ when $t = 4 \text{ sec.}$
16. (a) 14 m (b) $\langle 14, 10 \rangle$
 (c) 17.20 m (d) 20.34 m

Exercise 19.1

1. (a) $\bar{X} \sim N(100, 12^2/20)$
 (b) 0.3385 (c) 0.0312
2. (a) $\bar{X} \sim N(72, 8^2/50)$
 (b) 0.0987 (c) 0.4615
3. (a) $n = 74$ (b) $70 \leq n \leq 79$
4. (a) $n = 25$ (b) $25 < n < 100$
5. (a) 3 (b) $\mu = 3, \sigma = (\sqrt{3})/7$
 (c) $3 < n < 12$
6. (a) 18 (b) $\mu = 18, \sigma = 2/\sqrt{3}$
 (c) $48 < n < 108$
7. (a) Since, $X \sim \text{Normal}$, $\bar{X} \sim N(1.7, 0.026^2)$
 (b) 0.6497 (c) 0.9728
8. (a) Since, $X \sim \text{Normal}$,
 $\bar{X} \sim N(875, 11.7^2/\sqrt{20})$
 (b) 0.3346 (c) 0.0280
 (d) $n \geq 61$
9. (a) Since, $X \sim \text{Normal}$, $\bar{X} \sim N(175, 8.5206^2)$
 (b) $n = 90$ (c) 8
 (d) 1812
10. (a) Since, $X \sim \text{Normal}$, $\bar{X} \sim N(163, 9.8387^2)$
 (b) $n = 67$ (c) 35
 (d) 162
11. (a) $15, (\sqrt{42})/2; 15, (\sqrt{42})/10$
 (b) $5 \leq k \leq 10$
12. (a) $95, (\sqrt{19})/2; 95, (\sqrt{19})/12$
 (b) $3 \leq k \leq 18$
13. (a) $0.6, (\sqrt{57})/10$ (b) $0.6, (\sqrt{19})/20$

14. (a) $P(X = x) = 1/8 \quad x = 1, 2, 3, \dots, 7, 8$
 $\mu = 4.5, \sigma = 2.2913$
 (b) $4.5, 0.3819$
15. (a) $P(X = x) = 1/6 \quad x = 1, 2, 3, 4, 5, 6$
 $\mu = 3.5, \sigma = 1.7078$
 (b) $3.5, 0.4270$ (c) $19 \leq n \leq 291$

Exercise 19.2

1. (a) $\bar{X} \sim N(200, 35^2/60)$ (b) 0.9866
2. (a) $\bar{X} \sim N(4.5, 1.2^2/80)$ (b) 0.5439
3. (a) $\bar{X} \sim N(12, 4/3)$ (b) $1/12$ (c) 0.6135
4. (a) $\bar{X} \sim N(28, 108/49)$
 (b) (i) $1/18$ (ii) 0.4110 (c) $n \geq 82$
5. (a) 12 min (b) $\bar{X} \sim N(12, 49/90)$
 (c) (i) $3/7$ (ii) 0.08767 (d) 0.1660
6. (a) If $n < 30$, distribution for \bar{X} is not known,
 mean = 2 , s.d. = $(\sqrt{3})/(15\sqrt{n})$.
 If $n \geq 30$, by the CLT, $\bar{X} \sim \text{Normal}$
 mean = 2 , s.d. = $(\sqrt{3})/(15\sqrt{n})$.
 (b) (i) 0.6824 (ii) 0.8068
 The prob. of an event occurring increases
 as sample size n increases.
 (c) $n \geq 134$ (d) 0.9145
7. (a) (i) 0.8286 (ii) 0.9584 (b) $n = 240$
8. (a) (i) 0.7558 (ii) 0.8364 (b) 127.4 min.
9. (a) (i) 0.4115 (ii) 0.4718 (b) 87.2 min.
10. (a) $\bar{X} \sim N(0.15, 51/2000)$ (b) 0.1490
 (c) 29
11. (a) $\bar{X} \sim N(11/2, 33/200)$
 (b) (i) $3/10$ (ii) 0.8907 (c) 89
12. (a) $\bar{X} \sim N(7, 91/1000)$
 (b) (i) 0.3556 (ii) 0.4995 (c) 50
13. (a) $P(X = x) = 1/8$ for $x = 1, 2, 3, \dots, 7, 8$
 (b) $\bar{X} \sim N(9/2, 7/48)$ (c) 0.9048 (d) 0.7042
14. (a) $P(X = x) = 1/6$ for $x = 1, 2, 3, 4, 5, 6$
 Mean = $7/2$
 (b) $\bar{X} \sim N(7/2, 5/84)$ (c) 0.0202 (d) $n \geq 12$
15. (a) $5, 3(\sqrt{2})/2$ (b) $5, 3/10$
 (c) 0.9044 (d) 0.6408
16. (a) $P(X = x) = \frac{\binom{7}{x} \binom{3}{3-x}}{\binom{10}{3}}$ for $x = 0, 1, 2, 3$
 Mean = $21/10$
 (b) $\bar{X} \sim N(21/10, 49/5000)$ (c) 0.1562

Exercise 19.3

1. (a) $\bar{X} \sim N(20, 0.3^2)$ (b) $N(20, 0.3^2)$
2. (a) $\bar{X} \sim N(100, (7\sqrt{2}/10)^2)$
 (b) $N(100, (7\sqrt{2}/10)^2)$
3. $\bar{X} \sim N(50, 1/2)$
4. (a) $\bar{X} \sim N(3, 9/400)$ (b) $N(3, 9/400)$
5. (a) $\bar{X} \sim N(2, 1/250)$ (b) $N(2, 1/250)$

6. (a) $15, (5\sqrt{3})/3$ (b) $\bar{X} \sim N(15, 5/48)$
 (b) $N(15, 5/48)$
 7. (a) $0, (\sqrt{15})/5$ (b) $N(0, 1/200)$

Exercise 20.1

1. (a) 59.54, 5.7844 (b) 59.54, 5.7844
 2. (a) 13.5, 8.7115 (b) $N(13.5, 1.1246^2)$
 3. $\bar{X} \sim N(100, 9/8)$; $N(100, 9/8)$
 4. $\bar{X} \sim N(10, 1/5000)$; $N(10, 1/5000)$
 5. (a) $1, (\sqrt{30})/6$; $\bar{X} \sim N(1, (\sqrt{30}/60)^2)$
 (b) $N(0, 1)$
 6. (a) $5, (5\sqrt{3})/3$; $\bar{X} \sim N(5, (\sqrt{3}/6)^2)$
 (b) $N(0, 1)$; approx. $N(0, 1)$
 7. (a) 1.1, 0.9434, 0.9595
 (b) 0.5708
 8. (a) 11.4, 5.1743, 5.2628
 (b) 0.9367

Exercise 20.2

1. (a) $\bar{X} \sim N(33.7, 1.0733^2)$
 (b) (i) 33.7 ± 2.76 (ii) 33.7 ± 1.88
 (c) $n \geq 23$
 2. (a) $\bar{X} \sim N(201.4, 3.525^2)$
 (b) (i) 201.4 ± 5.80 (ii) 201.4 ± 7.65
 (c) $n \geq 48$
 3. (a) $\bar{X} \sim N(5.4, 0.12^2)$
 (b) (i) 5.4 ± 0.24 (ii) 5.4 ± 0.34
 (c) $n \geq 98$
 4. (a) (i) 20.7 ± 0.57 (ii) 20.7 ± 1.14
 (b) $n \geq 46$
 5. (a) (i) 0.3341 (ii) 0.01606
 (b) (i) 485 ± 5.76 (ii) 485 ± 6.13
 (c) $n \geq 25$
 6. (a) 0.9431 (b) 125 ± 4.89 (c) $n \geq 28$
 7. (a) 0.1030 (b) 12 ± 1.55 (c) 79.4%
 8. (a) 0.9605 (b) 2.5 ± 0.089 (c) 88.6%
 9. (a) 183 ± 1.18 (b) 90.4% (c) $n \geq 60$
 10. (a) 1.645 (b) $29.8 \leq \mu \leq 30.2$
 11. (a) $9.993 \leq \mu \leq 10.007$
 $9.991 \leq \mu \leq 10.009$
 $9.988 \leq \mu \leq 10.012$
 (b) No cause.
 12. (a) $999.81 \leq \mu \leq 1000.19$
 $999.77 \leq \mu \leq 1000.23$
 $999.70 \leq \mu \leq 1000.3$
 (b) No cause.

Exercise 20.3

1. Significant at 10%, 5% and 1% levels.
 2. Significant at 10% and 5% but not at 1%.
 3. Significant at 10%, 8% and 2% levels.
 4. (a) Significant at 5% level.
 (b) 15.7%
 5. (a) 5.9% (b) (i) $n \geq 55$ (ii) $n \geq 39$
 6. (a) 2.5% (b) (i) $n \geq 107$ (ii) $n \geq 62$

Index

- absolute value functions
graph of, 68
- angle
between line and plane, 112
between two planes, 113
between two vectors, 85
- anti-differentiation, 172
- area, trapped between two curves, 199
- asymptotes, 74
oblique, 82
- Cartesian
equation of line, 101
equation of plane, 107
equation of circle, 115
- Central Limit Theorem, 272, 276
- circular motion, 261
- Complex Conjugate Root Theorem, 41
- complex numbers, 1
Argand diagram, 1, 7
argument, 2
Cartesian form, 1
cis form, 2
conjugate, 2
exponential form, 26
locus, 11
modulus, 2
*n*th roots, 21
ordered pair, 2
polar form, 2
roots, 2
trigonometry, 23
- confidence intervals for μ , 294
- critical region, 304
- de Moivre's Theorem, 4
- differential equations, 214
 $\frac{dy}{dx} = f(x)$, 214
 $\frac{d^2x}{dt^2} = -\omega^2 x$, 245
 $\frac{dy}{dt} = ay + b$, 216
 $\frac{dy}{dt} = ay(b - y)$, 222
 $\frac{dy}{dx} = f(x)g(y)$, 228
separation of variables, 216
- differentiation, 152
applications, 164
exponential functions, 152
implicit, 158
logarithmic, 162
logarithmic functions, 152
parametric function, 156
rules, 152
trigonometric functions, 152
- echelon form, 138
- elementary row operations, 138
- elliptical motion, 261
- Factor Theorem, 32
- functions, 45
codomain, 45
composition of, 49
domain, 45
inverse, 57
many to one, 45
one to one, 45
onto, 45
range, 45
- Fundamental Theorem of Algebra, 19
- Fundamental Theorem of Calculus, 173
- Gaussian elimination method, 137
- geometric proofs, using vectors, 129
- geometry in 3D space, 133
- gradient function, 164
- graphs of
absolute value functions, 68
inverses, 63
rational functions, 74
reciprocals, 64
- Heaviside Cover-up Method, 195
- integrals
standard, 173
trigonometric, 178
- integration,
change of variable, 185, 197
definite, 196
partial fractions, 191, 196
trigonometric substitution, 189
- interval estimate for μ , 294
- isoclines, 235
- level of significance, 304
- logistic differential equation, 222
- logistic function, 222

- Matrices,
 - augmented, 137
- Motion in a plane
 - circular motion, 260
 - elliptical motion, 260
 - projectile motion, 266
- Numerical integration, 208
 - mid point rule, 209
 - rectangular rules, 208
 - Simpson's rule, 212
 - Trapezium rule, 210
- partial fractions, 191
- piecewise defined functions, 68, 70
- poles, 74
- point estimate for μ , 288
- polynomial division, 37
- projectile motion, 266
- rational functions, 74
- rectilinear motion, 239
- related rates, 166
- Remainder Theorem, 35
- sampling distribution
 - of sample means, 272, 289
 - simulations, 283
- scalar product
 - equation of line, 105
- scalar projection, 85
- separation of variables, 216
- shortest distance between
 - point and line, 118
 - point and plane, 119
- simple harmonic motion, 246
- systems of linear equations, 136
 - existence of solutions, 145
 - Gaussian elimination method, 137
 - infinite solutions, 146
 - no solution, 147
 - unique solution, 137, 146
- vectors
 - acceleration, 256
 - angle between, 85
 - cross product, 94
 - components, 84
 - direction, 84
 - direction cosines, 85
 - displacement, 256
 - magnitude, 84
 - normal, 95
 - parallel, 85
 - perpendicular, 2
 - position, 84
 - projection, 85
 - proofs, 129
 - scalar product, 85
 - unit, 85
 - velocity, 256
- vector equation
 - of line, 98
 - of plane, 107
 - of sphere, 115
 - scalar product, 105
- vector functions, 122, 253
 - derivatives, 253
 - integrals, 253
- volume of revolution, 203
- zeros, 32

The following titles are available from Academic Group Pty Ltd:

ACADEMIC ASSOCIATES STUDY GUIDES

Year 11

Accounting & Finance Year 11 ATAR Course Study Guide
Biology Year 11 ATAR Course Study Guide
Chemistry Year 11 ATAR Course Study Guide
Economics Year 11 ATAR Course Study Guide
Human Biology Year 11 ATAR Course Study Guide
Mathematics Applications Year 11 ATAR Course Study Guide
Mathematics Methods Year 11 ATAR Course Study Guide
Mathematics Specialist Year 11 ATAR Course Study Guide
Physics Year 11 ATAR Course Study Guide
Psychology Year 11 ATAR Course Study Guide

Year 12

Accounting & Finance Year 12 ATAR Course Study Guide
Biology Year 12 ATAR Course Study Guide
Chemistry Year 12 ATAR Course Study Guide
Economics Year 12 ATAR Course Study Guide
Human Biology Year 12 ATAR Course Study Guide
Mathematics Applications Year 12 ATAR Course Study Guide
Mathematics Methods Year 12 ATAR Course Study Guide
Mathematics Specialist Year 12 ATAR Course Study Guide
Physics Year 12 ATAR Course Study Guide
Psychology Year 12 ATAR Course Study Guide

ACADEMIC TASK FORCE REVISION SERIES

Year 11

Chemistry Year 11 ATAR Course Revision Series
Mathematics Applications Year 11 ATAR Course Revision Series
Mathematical Methods Year 11 ATAR Course Revision Series
Mathematics Specialist Year 11 ATAR Course Revision Series
Physics Year 11 ATAR Course Revision Series

Year 12

Chemistry Year 12 ATAR Course Revision Series
Mathematics Applications Year 12 ATAR Course Revision Series
Mathematical Methods Year 12 ATAR Course Revision Series
Mathematics Specialist Year 12 ATAR Course Revision Series
Physics Year 12 ATAR Course Revision Series

ATAR COURSE TEXTBOOKS

Mathematical Methods Year 11
Mathematics Specialist Year 11
Mathematical Methods Year 12
Mathematics Specialist Year 12

CREELMAN EXAM QUESTIONS

Year 12

Accounting & Finance
Biological Sciences
Chemistry
Economics
Geography
Human Biological Sciences
Mathematics
Mathematics
Mathematics Specialist
Physics
Politics and Law

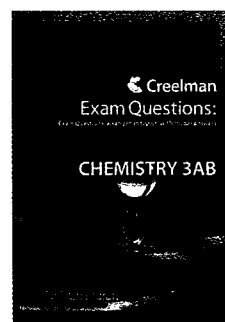
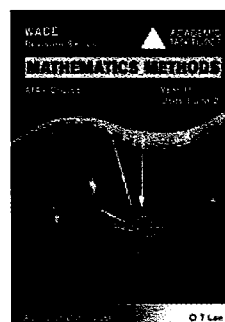
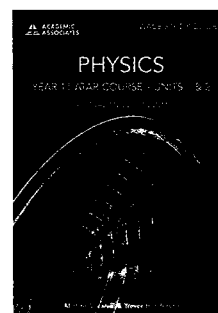

ATAR HELP

If you have found this Guide useful and would like more help please contact ACADEMIC TASK FORCE for information about ACADEMIC GROUP Programs.



- ATAR Course Revision programs in January, April, July and October Holidays.
- Special Study Skills and Essay Writing Courses .
- Weekend small group classes for ongoing help throughout the year.
- ATAR Master Classes for teaching extension.
- Individual tuition in your home.

Ensure your ATAR Success through ACADEMIC TASK FORCE programs.

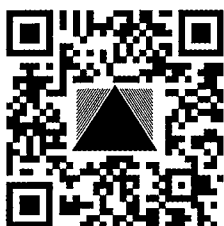

Enrol in our courses at www.academictaskforce.com.au

Want to be kept up to date about upcoming courses?

Email learn@academictaskforce.com.au and tell us your name and address and we will add you to our loyalty member's mailout where you can receive notice of Early Bird enrolment discounts and all our upcoming courses.



Follow us on Facebook for exam and study tips

Visit www.academictaskforce.com.au for insider tips from our specialist ATAR course exam markers and teachers in our **video blogs** series.

Contact Us: ACADEMIC TASK FORCE
PO Box 627, APPLECROSS WA 6953

Phone: (08) 9314 9500

Email: learn@academictaskforce.com.au

